

Owner's Manual
for Vehicle



The Ultimate
Driving Machine



THE BMW 3 SERIES.

OWNER'S MANUAL.

BMW EfficientDynamics
Less emissions. More driving pleasure.

328i
328i xDrive
335i
335i xDrive
335is
M3

Owner's Manual for Vehicle

Congratulations, and thank you for choosing a BMW.

Thorough familiarity with your vehicle will provide you with enhanced control and security when you drive it. We therefore have this request:

Please take the time to read this Owner's Manual and familiarize yourself with the information that we have compiled for you before starting off in your new vehicle. It contains important data and instructions intended to assist you in gaining maximum use and satisfaction from your BMW's unique range of technical features. The manual also contains information on maintenance designed to enhance operating safety and contribute to maintaining the value of your BMW throughout an extended service life.

This manual is supplemented by a Service and Warranty Information Booklet for US models or a Warranty and Service Guide Booklet for Canadian models.

Please also read the other booklets of vehicle literature, e.g. the Supplementary Owner's Handbook for the BMW M3.

We wish you an enjoyable driving experience.

BMW Group

© 2011 Bayerische Motoren Werke
Aktiengesellschaft
Munich, Germany

Reprinting, including excerpts, only with the
written consent of BMW AG, Munich.

US English VIII/11, 09 11 450

Printed on environmentally friendly paper,
bleached without chlorine, suitable for recycling.

Contents

The quickest way to find special topics is to consult the index, refer to page [240](#).

- [4](#) Notes
- [7](#) Reporting safety defects

At a glance

- [10](#) Dashboard
- [18](#) Radio

Controls

- [24](#) Opening and closing
- [42](#) Adjustments
- [53](#) Transporting children safely
- [57](#) Driving
- [78](#) Controls overview
- [89](#) Technology for driving comfort and safety
- [103](#) Lamps
- [109](#) Climate
- [116](#) Practical interior accessories

Driving tips

- [132](#) Things to remember when driving

Entertainment

- [142](#) BMW Professional radio

Communications

- [156](#) Telephone
- [167](#) ConnectedDrive

Mobility

- [174](#) Refueling
- [177](#) Wheels and tires
- [197](#) Engine compartment
- [202](#) Maintenance
- [204](#) Care
- [208](#) Replacing components
- [214](#) Giving and receiving assistance
- [220](#) Indicator and warning lamps

Reference

- [234](#) Technical data
- [240](#) Everything from A to Z

Notes

Using this Owner's Manual

We have tried to make all the information in this Owner's Manual easy to find. The fastest way to find specific topics is to refer to the detailed index at the back of the manual. If you wish to gain an initial overview of your vehicle, you will find this in the first chapter.

Should you sell your BMW some day, please remember to hand over the Owner's Manual as well; it is an important component of your vehicle.

Updates after press date

Updates after press date for the Owner's Manuals, when necessary, are issued as appendices to the printed Quick Reference Guide for the vehicle.

Additional sources of information

Should you have any other questions, your BMW center will be glad to advise you at any time.

Information on BMW, e.g. on technical aspects, can also be found on the Internet at www.bmwusa.com.

Symbols used



Indicates precautions that must be followed precisely in order to avoid the possibility of personal injury and serious damage to the vehicle. ◀



Indicates information that will assist you in gaining the optimum benefit from your vehicle and enable you to care more effectively for your vehicle. ◀



Refers to measures that can be taken to help protect the environment. ◀

◀ Marks the end of a specific item of information.

Symbols on vehicle components



Indicates that you should consult the relevant section of this Owner's Manual for information on a particular part or assembly.

Vehicle equipment

This Owner's Manual describes all models and all series-specific equipment, country-specific equipment, and optional equipment that is offered in the series. For this reason, this Owner's Manual also describes and illustrates some equipment that may not be available in your vehicle, for example due to the special options or national-market version selected.

This also applies to safety related functions and systems.

If equipment and models are not described in this Owner's Manual, please consult the accompanying Supplementary Owner's Handbooks.

Status of this Owner's Manual at time of printing

BMW pursues a policy of continuous, ongoing development that is conceived to ensure that our vehicles continue to embody the highest quality and safety standards combined with advanced, state-of-the-art technology. For this reason, it is possible in exceptional cases that features described in this Owner's Manual could differ from those on your vehicle.

Updates after press date

Updates after press date for the Owner's Manuals, when necessary, are issued as appendices to the printed Quick Reference Guide for the vehicle.

For your own safety

Maintenance and repair



Advanced technology, e.g. the use of modern materials and powerful electronics, requires specially adapted maintenance and repair methods. You should therefore have the corresponding work on your vehicle performed only by your BMW center or at a work-

shop that works according to BMW repair procedures with correspondingly trained personnel. If this work is not carried out properly, there is a danger of subsequent damage and related safety hazards. ◀

Parts and accessories



For your own safety, use genuine parts and accessories approved by BMW.

When you purchase accessories tested and approved by BMW and Original BMW Parts, you simultaneously acquire the assurance that they have been thoroughly tested by BMW to ensure optimum performance when installed on your vehicle.

BMW warrants these parts to be free from defects in material and workmanship.

BMW will not accept any liability for damage resulting from installation of parts and accessories not approved by BMW.

BMW cannot test every product made by other manufacturers to verify if it can be used on a BMW safely and without risk to either the vehicle, its operation, or its occupants.

Original BMW Parts, BMW Accessories and other products approved by BMW, together with professional advice on using these items, are available from all BMW centers.

Installation and operation of accessories not approved by BMW, such as alarms, radios, amplifiers, radar detectors, wheels, suspension components, brake dust shields, telephones, including operation of any mobile phone from within the vehicle without using an externally mounted antenna, or transceiver equipment, for instance, CBs, walkie-talkies, ham radio or similar accessories, may cause extensive damage to the vehicle, compromise its safety, interfere with the vehicle's electrical system or affect the validity of the BMW Limited Warranty. See your BMW center for additional information. ◀

 Maintenance, replacement, or repair of the emission control devices and systems may be performed by any automotive repair establishment or individual using any certified automotive part. ◀

California Proposition 65 warning

California law requires us to issue the following warning:

 Engine exhaust and a wide variety of automobile components and parts, including components found in the interior furnishings in a vehicle, contain or emit chemicals known to the State of California to cause cancer and birth defects and reproductive harm. In addition, certain fluids contained in vehicles and certain products of component wear contain or emit chemicals known to the State of California to cause cancer and birth defects or other reproductive harm.

Battery posts, terminals and related accessories contain lead and lead compounds. Wash your hands after handling.

Used engine oil contains chemicals that have caused cancer in laboratory animals. Always protect your skin by washing thoroughly with soap and water. ◀

Service and warranty

We recommend that you read this publication thoroughly.

Your BMW is covered by the following warranties:

- ▷ New Vehicle Limited Warranty
- ▷ Rust Perforation Limited Warranty
- ▷ Federal Emissions System Defect Warranty
- ▷ Federal Emissions Performance Warranty
- ▷ California Emission Control System Limited Warranty

Detailed information about these warranties is listed in the Service and Warranty Information Booklet for US models or in the Warranty and Service Guide Booklet for Canadian models.

Your vehicle has been specifically adapted and designed to meet the particular operating conditions and registration requirements in your country and continental region in order to deliver the full driving pleasure while the vehicle is operated under those conditions. If you wish to operate your vehicle in another country or region, you may be required to adapt your vehicle to meet different prevailing operating conditions and registration requirements. You should also be aware of any applicable warranty limitations or exclusions for such country or region. In such case, please contact Customer Relations for further information.

Maintenance

Maintain the vehicle regularly to sustain the road safety, operational reliability and the New Vehicle Limited Warranty.

Specifications for required maintenance measures:

- ▷ BMW Maintenance system
- ▷ Service and Warranty Information Booklet for US models
- ▷ Warranty and Service Guide Booklet for Canadian models

If the vehicle is not maintained according to these specifications, this could result in serious damage to the vehicle. Such damage is not covered by the BMW New Vehicle Limited Warranty.

Reporting safety defects

For US customers

The following only applies to vehicles owned and operated in the US.

If you believe that your vehicle has a defect which could cause a crash or could cause injury or death, you should immediately inform the National Highway Traffic Safety Administration, NHTSA, in addition to notifying BMW of North America, LLC, P.O. Box 1227, Westwood, New Jersey 07675-1227, Telephone 1-800-831-1117.

If NHTSA receives similar complaints, it may open an investigation, and if it finds that a safety defect exists in a group of vehicles, it may order a recall and remedy campaign. However, NHTSA cannot become involved in individual problems between you, your center, or BMW of North America, LLC.

To contact NHTSA, you may call the Vehicle Safety Hotline toll-free at 1-888-327-4236 (TTY: 1-800-424-9153); go to <http://www.safercar.gov>; or write to: Administrator, NHTSA, 400 Seventh Street, SW., Washington, DC 20590. You can also obtain other information about motor vehicle safety from <http://www.safercar.gov>

For Canadian customers

Canadian customers who wish to report a safety-related defect to Transport Canada, Defect Investigations and Recalls, may telephone the toll-free hotline 1-800-333-0510. You can also obtain other information about motor vehicle safety from <http://www.tc.gc.ca/roadsafety>



At a glance

This overview of buttons, switches and displays is intended to familiarize you with your vehicle's operating environment. The section will also assist you in becoming acquainted with the control concepts and options available for operating the various systems.

Dashboard









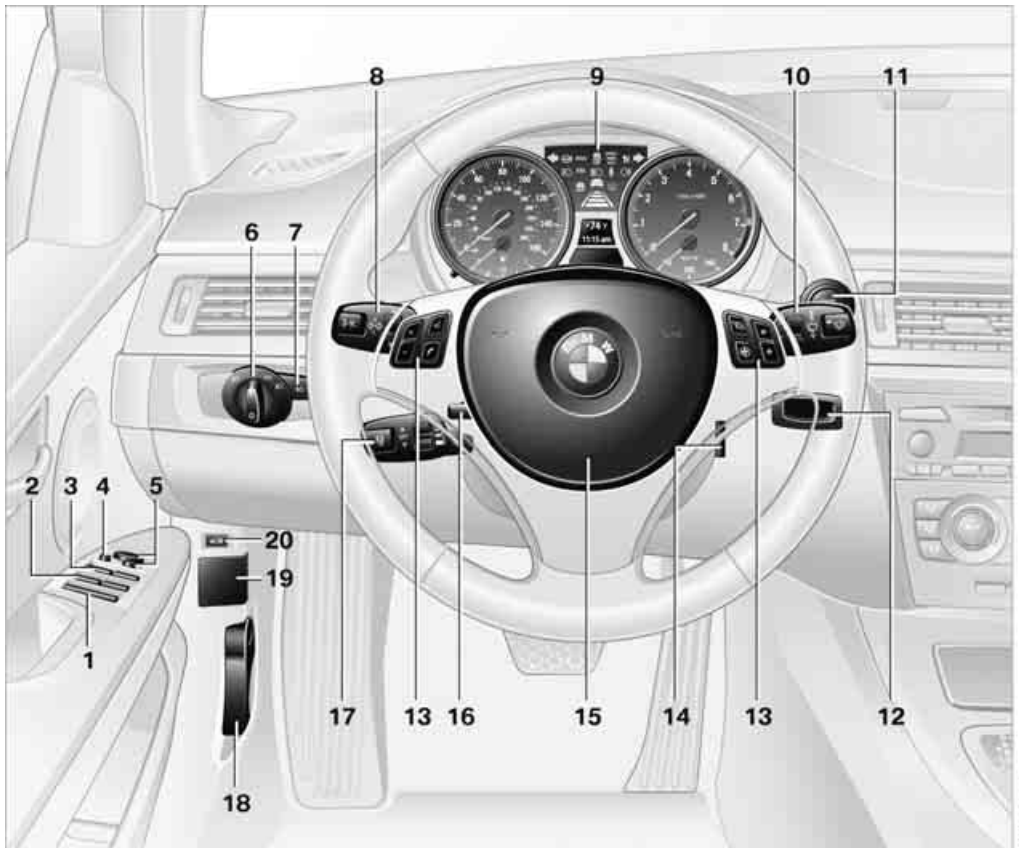





















Vehicle equipment

In this chapter, all production, country, and optional equipment that is offered in the model range is described. For this reason, descriptions will be given of some equipment that may

not be available in a vehicle, for example due to the special options or national-market version selected. This also applies to safety related functions and systems.

Around the steering wheel: controls and displays



- 1  Convertible: opening and closing windows jointly 35
- 2  Convertible: opening and closing rear windows 35
- 3  Opening and closing front windows 35
- 4 Exterior mirrors folding in and out 50
- 5 Adjusting exterior mirrors, automatic curb monitor 50
- 6  Parking lamps 103
-  Low beams 103
-  Automatic headlamp control 103
-  Adaptive Light Control 105
-  High-beam Assistant 106
- 7  Fog lamps 107
- 8  Turn signals 67
-  High beams, headlamp flasher 105
-  High-beam Assistant 106
-  Roadside parking lamps 105
-  Computer 80
-  Settings and information about the vehicle 82
- 9 Instrument cluster 12
- 10  Windshield wipers 68
-  Rain sensor 68
- 11  Switching the ignition on/off and starting/stopping the engine 57
- 12 Ignition lock 57
- 13 Buttons on the steering wheel
-  Telephone: accepting and ending a call; dialing the selected phone number; redialing if no phone number is selected
- Convertible: microphone on steering column
-  Volume
-  Voice commands for telephone 163
- Convertible: microphone on steering column
-  Changing the radio station
-  Interrupting a traffic bulletin
-  Selecting a music track
-  Scrolling through the redial list
-  Next entertainment source
-  Recirculated air mode 113
- 14  Steering wheel heating 52
- 15 Horn, entire surface
- 16 Adjusting the steering wheel 52
- 17  Cruise control 71
-  Active Cruise Control 71
- 18 Releasing the hood 198
- 19 OBD socket 203
- 20 Opening the trunk lid 31

Instrument cluster



- 1 Speedometer
- 2 Indicator lamps for turn signals
- 3 Indicator and warning lamps [13](#)
- 4 Displays for Active Cruise Control [71](#)
- 5 Tachometer [79](#)
- 6 Engine oil temperature [79](#)
- 7 Display for
 - ▷ Clock [78](#)
 - ▷ Outside temperature [78](#)
 - ▷ Indicator and warning lamps [87](#)
- 8 Display for
 - ▷ Position of automatic transmission [60](#)
 - ▷ Gear indicator of 7-gear Sport automatic transmission with double clutch [62](#)
 - ▷ Computer [80](#)
 - ▷ Date of next scheduled service, and remaining distance to be driven [84](#)
 - ▷ Odometer and trip odometer [78](#)
 - ▷ High-beam Assistant [106](#)
 - ▷ Initializing Flat Tire Monitor [93](#)
 - ▷ Resetting the Tire Pressure Monitor [95](#)
 - ▷ Checking the oil level [198](#)
 - ▷ Settings and information [82](#)
 - ▷  There is a Check Control message [87](#)
- 9 Fuel gauge [79](#)
- 10 Resetting the trip odometer [78](#)

Indicator and warning lamps

The concept

Indicator and warning lamps can light up in a variety of combinations and colors.





Several of the lamps are checked for proper functioning and light up temporarily when the engine is started or the ignition is switched on.







What to do in case of a malfunction





A list of all indicator and warning lamps, as well as notes on possible causes of malfunctions and on how to respond, can be found starting on page [220](#).

Around the center console: controls and displays



- | | |
|--|--|
| <p>1 Hazard warning flashers</p> <p>2 Driving stability control systems</p> <ul style="list-style-type: none"> ▷ Dynamic Stability Control DSC 90 ▷ Dynamic Traction Control DTC 91 <p>3 Central locking system 29</p> <p>4 Radio 18</p> | <p>5 Air conditioner or automatic climate control</p> <ul style="list-style-type: none">  Air distribution for air conditioner 110  Air distribution to the windshield 112  Air distribution to the upper body area 112  Air distribution to the footwell 112 AUTO Automatic air distribution and flow rate 113  Cooling function 114 |
|--|--|





-  Automatic recirculated air control
AUC and recirculated air
mode [113](#)
-  Recirculated air mode [110](#)
-  Maximum cooling [113](#)
- ALL** ALL program [114](#)
-  Air volume [110](#), [113](#)
-  Defrosting windows [114](#)
-  Rear window defroster [111](#), [114](#)
-  Seat heating [48](#)

- 6**  Park Distance Control PDC [89](#)
-  Coupe:
Roller sunblinds [120](#)
-  Coupe:
Hill Descent Control HDC [92](#)
- 7**  Convertible:
Opening and closing retractable
hardtop [38](#)

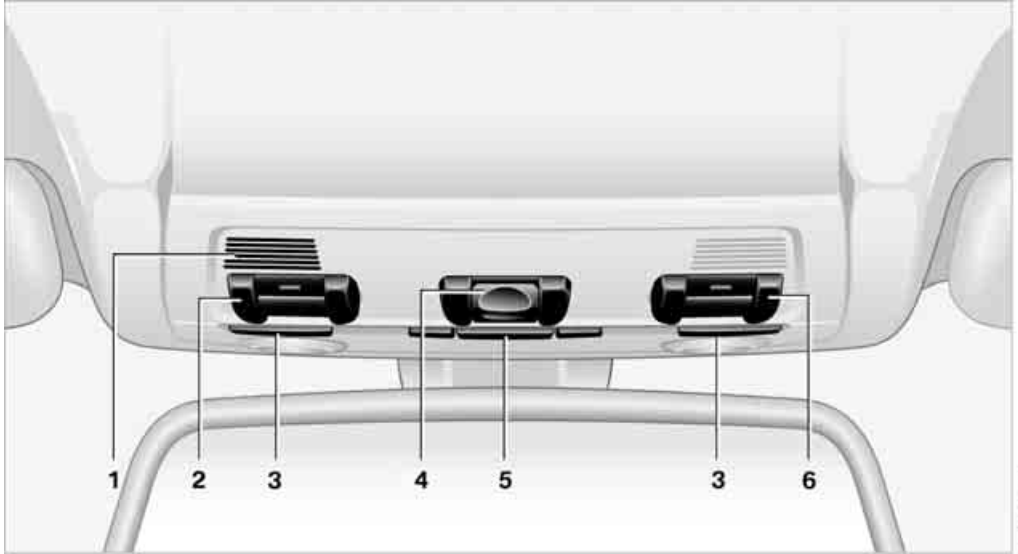
Around the roofliner





Coupe

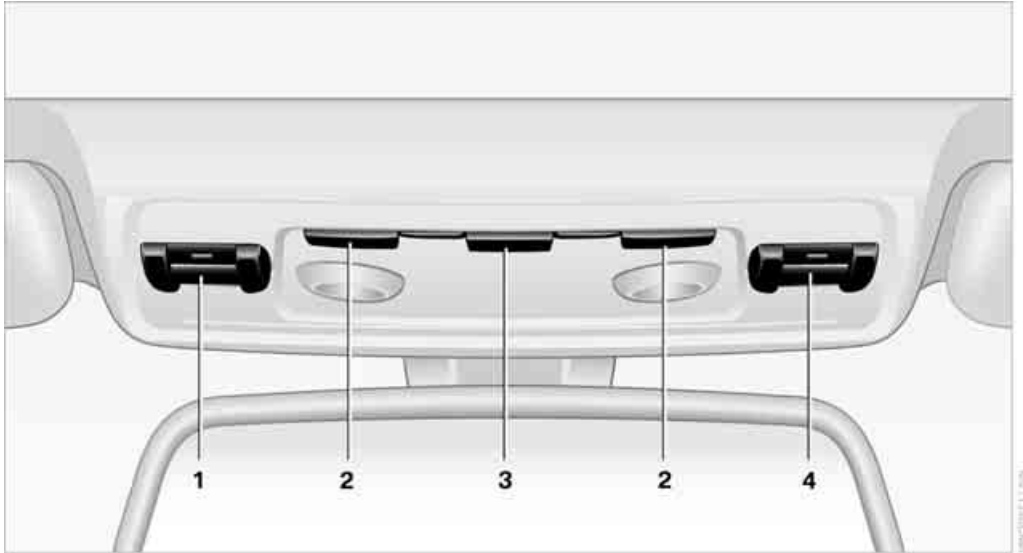

- 1 Microphone for telephone in hands-free mode
- 2  SOS: sending an Emergency Request [214](#)
- 3  Reading lamps [108](#)
- 4  Glass sunroof [37](#)
- 5  Interior lamps [107](#)
- 6  Passenger airbag status lamp [100](#)

Convertible



- 1  SOS: sending an Emergency Request [214](#)
- 2  Reading lamps [108](#)
- 3  Interior lamps [107](#)
- 4  Passenger airbag status lamp [100](#)

Radio

Vehicle equipment

In this chapter, all production, country, and optional equipment that is offered in the model range is described. For this reason, descriptions will be given of some equipment that may

not be available in a vehicle, for example due to the special options or national-market version selected. This also applies to safety related functions and systems.

BMW Professional radio

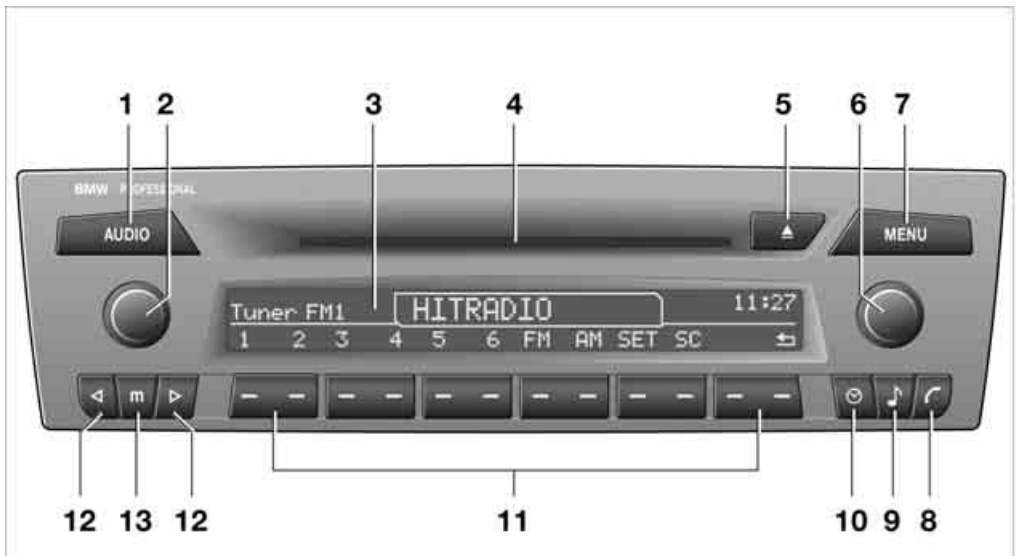

- | | |
|---|---|
| <p>1 Changing audio sources</p> <ul style="list-style-type: none"> ▷ Radio ▷ HD Radio ▷ Satellite radio ▷ CD player ▷ CD changer ▷ External audio device, e.g. MP3 player ▷ USB audio interface <p>2 Volume control, ON/OFF. 142</p> | <p>3 Display for</p> <ul style="list-style-type: none"> ▷ Radio ▷ CD ▷ Telephone ▷ Computer ▷ External audio device, e.g. MP3 player ▷ USB audio interface ▷ Tone setting ▷ Time display <p>4 CD slot</p> <p>5 Ejecting CD 148</p> |
|---|---|

- 6 Selecting functions
 - ▷ Turn: selecting menu item or setting a value
 - ▷ Press: confirming selection or storing settings
- 7 MENU, changing to
 - ▷ Telephone
 - ▷ Computer
 - ▷ Adjusting
 - ▷ BMW phone numbers
- 8 Establishing/ending telephone connections
- 9 Opening the settings
 - ▷ Speed-dependent volume 143
 - ▷ Tone setting 143
 - ▷ Surround sound function 143
- 10 Displaying the time
- 11 Function buttons for confirming the menu items displayed above them
- 12 Changing stations or tracks
 - ▷ Changing stations 144
 - ▷ Changing tracks with the CD player 148
- 13 Selecting the frequency manually 144

Presentation in the Owner's Manual

"..." identifies radio display texts used to select individual functions.

Menu navigation

All radio functions can be accessed using the buttons on the radio and using the menus.

Opening audio menu

AUDIO Press the button.

The menu of audio sources appears on the display.

Opening settings menu

MENU Press the button.

The settings menu appears on the display.

Selecting a menu item

Menu items can be selected using either the knob on the right or the function buttons.

Using the knob on the right



1. Highlighting a menu item: turn the knob on the right, arrow 1.
2. Select a menu item: press the knob on the right, arrow 2.

Using the function buttons

SET SC Press the left or right side of the function button under the menu item.

If only one menu item is displayed above a function button, press the middle of the button.

Setting values

To set numerical values or values on a scale:

1. Select the desired menu item and press the knob on the right.
2. Turn the knob on the right to set the value.
3. Press the knob on the right to store the value.

Symbols on the display

Symbol	Function
✓	Function is selected
☑	The function is activated
☐	The function is deactivated
↶	Exit menu, go back one menu
▶	Show other menu items
◀	
⬆	Scroll display, list contains more than 2 entries
↑	Changing to a higher level directory



Controls

This chapter is intended to provide you with information for complete control of your vehicle. All features and accessories that are useful for driving and your safety, comfort and convenience, are described here.

Opening and closing

Vehicle equipment

In this chapter, all production, country, and optional equipment that is offered in the model range is described. For this reason, descriptions will be given of some equipment that may not be available in a vehicle, for example due to the special options or national-market version selected. This also applies to safety related functions and systems.

Remote control



Each remote control contains a rechargeable battery that is automatically recharged when it is in the ignition lock while the car is being driven. Use each remote control at least twice a year for longer road trips in order to maintain the batteries' charge status. In cars with Comfort Access, the remote control contains a replaceable battery, refer to page 35.

The settings called up and implemented when the car is unlocked depend on which remote control is used to unlock the car, refer to Personal Profile, next column.

In addition, information about service requirements is stored in the remote control, refer to Service data in the remote control, page 202.

Integrated key



Press button 1 to release the key.

The integrated key fits the following locks:

- ▷ Glove compartment, refer to page 120
- ▷ Driver's door, refer to page 29

New remote controls

Your BMW center can supply new remote controls with integrated keys as additional units or as replacements in the event of loss.

Personal Profile

The concept

You can set many of your BMW's functions to suit your personal needs and preferences. Without any action on your part, Personal Profile ensures that most of these settings are stored for the remote control currently in use. When you unlock the car, the remote control used for the purpose is recognized and the settings stored for it are called up and implemented.

This means that your personal settings will be activated for you, even if in the meantime your car was used by someone else with another remote control and the corresponding settings. The individual settings are stored for a maximum of four remote controls. They are stored for two remote controls if Comfort Access is in use.

Personal Profile settings

For more information on specific settings, refer to the specified pages.

- ▷ Response of the central locking system when the car is unlocked, refer to page 25
- ▷ Automatic locking of the vehicle, refer to page 29
- ▷ Automatic call-up of the driver's seat position, refer to page 48
- ▷ Triple turn signal activation, refer to page 67
- ▷ Settings for the display in the instrument cluster:
 - ▷ 12h/24h format of the clock, refer to page 83
 - ▷ Date format, refer to page 83
 - ▷ Units of measure, refer to page 83
- ▷ Light settings:
 - ▷ Pathway lighting, refer to page 104
 - ▷ Daytime running lights, refer to page 104
 - ▷ High-beam Assistant, refer to page 106
- ▷ Automatic climate control: AUTO program, cooling function and automatic recirculated air control activated/deactivated, temperature, air volume and distribution, refer to page 112 ff
- ▷ Entertainment:
 - ▷ Speed-dependent volume control, refer to page 143

Central locking system

The concept

The central locking system functions when the driver's door is closed.

The system simultaneously engages and releases the locks on the following:

- ▷ Doors
- ▷ Trunk lid

- ▷ Fuel filler flap
- ▷ Convertible: glove compartment

Operating from outside

- ▷ Via the remote control
- ▷ Using the door lock
- ▷ In cars with Comfort Access, via the handles on the driver's door and the front passenger door

At the same time as locking and unlocking via the remote control:

- ▷ Welcome lights, the interior light, and the courtesy lighting are switched on and off.
- ▷ Alarm system, refer to page 32, is armed or disarmed.

Operating from inside

By means of the button for central locking, refer to page 29.

In the event of a sufficiently severe accident, the central locking system unlocks automatically. In addition, the hazard warning flashers and interior lamps come on.

Opening and closing: Using the remote control



Persons or animals in a parked vehicle could lock the doors from the inside. You should therefore take the remote control with you when you leave the vehicle so that the latter can be opened from outside. ◀



Convertible: to operate the retractable hardtop with the remote control, the doors and trunk lid must be closed and the cargo area partition must be folded down and engaged on both sides. Refer also to page 39. ◀

Unlocking

Press the  button.

The interior lamps, the courtesy lighting of the doors, and the welcome lamps come on.

Setting unlocking characteristics

You can set whether only the driver's door or the entire vehicle is to be unlocked when the button is pressed for the first time.

For operating principle, refer to page 82.

1. Switch on the ignition, refer to page 57.
2. Briefly press button **1** in the turn signal/high beam lever up or down repeatedly until the symbol appears in the display, accompanied by the word "SET".



3. Press button **2**.
4. Briefly press button **1** in the turn signal/high beam lever down repeatedly until the symbol appears in the display.



5. Press button **2**.
6. Use button **1** to select:
 - ▷ Press the button once to unlock only the driver's door and the fuel filler flap. Press the button twice to unlock the entire vehicle.
 - ▷ Press the button once to unlock the entire vehicle.

7. Press button **2**.
The setting is stored for the remote control currently in use.

Coupe: convenient opening

Press and hold the button.
The windows and the glass roof are opened.

Convertible: convenient opening

When you are close to the vehicle, the remote control for Comfort Access can be used to open the retractable hardtop.

Hold the button down.
The windows and the retractable hardtop are opened if the doors are closed.

If you continue pressing the button, the windows move up.

Watch during the opening process to ensure that no one is injured. Releasing the button interrupts the opening process. ◀

Locking

Press the LOCK button.

Do not lock the vehicle from the outside if there is any person inside, because the vehicle cannot be unlocked from inside without special knowledge. ◀

Convertible: convenient closing

When you are close to the vehicle, the remote control for Comfort Access can be used to close the retractable hardtop and the windows.

Press and hold the LOCK button.
The retractable hardtop and the windows are closed.

Watch during the closing process to ensure that no one is injured. Releasing the button interrupts the closing process. ◀

Switching on interior lamps

While the car is locked:

Press the  LOCK button.

You can also use this function to locate your vehicle in parking garages etc.

Unlocking the trunk lid



Press the  button for about 1 second and then release it.

The trunk lid opens a short distance, regardless of whether it was locked or unlocked.

 The trunk lid swings back and up when opened. Ensure that there is sufficient clearance. To avoid locking yourself out by accident, do not place the remote control in the cargo area. A previously locked trunk lid is locked again after closing. Before and after each trip, check that the trunk lid has not been inadvertently unlocked. ◀

Convertible: convenient loading

When you are close to the vehicle, the remote control for Comfort Access can be used to partially raise the open hardtop for more convenient loading of the cargo area.

1. Briefly press the  button and, within one second, press again and hold until the retractable hardtop stops in an intermediate position. The trunk lid opens slightly.
2. Open the trunk lid, press the cargo area partition upward and stow the cargo in the cargo area.
3. Press down the cargo area partition until it engages on both sides and close the trunk lid.
4. Press the  button for a longer period to fold the retractable hardtop back in.

Confirmation signals

You can activate or deactivate the confirmation signals.





For operating principle, refer to page 82.

1. Switch on the ignition, refer to page 57.
2. Briefly press button 1 in the turn signal/high beam lever up or down repeatedly until the symbol appears in the display, accompanied by the word "SET".



3. Press button 2.
4. Briefly press button 1 in the turn signal/high beam lever down repeatedly until the desired symbol appears in the display.



- ▶  Confirmation signal during unlocking
 - ▶  Confirmation signal during locking
5. Press button 2.
 6. Use button 1 to select:
 - ▶  The hazard warning flashers are activated during unlocking/locking.
 - ▶  An acoustic signal sounds during unlocking/locking.



The hazard warning flashers are activated and an acoustic signal sounds during unlocking/locking.



The function is deactivated.

- Press button **2**.
The setting is stored.

Calling up the driver's seat position

The driver's seat position last set is stored for the remote control currently in use.

You can select whether or not the seat is reset to that position automatically.

 When this Personal Profile function is used, first make sure that the footwell behind the driver's seat is free of obstacles. Failure to do so could cause injury to persons or damage to objects as a result of a rearward movement of the seat. ◀

The adjusting procedure is halted immediately when you touch a seat adjustment switch or one of the memory buttons.

Activating/deactivating automatic call-up

For operating principle refer to page 82.



- Briefly press button **1** in the turn signal/high beam lever up or down repeatedly until the symbol appears in the display, accompanied by the word "SET".



- Press button **2**.

- Briefly press button **1** in the turn signal/high beam lever down repeatedly until the symbol appears in the display.



- Press button **2**.
- Use button **1** to select:
 - ▷  Call-up when the vehicle is unlocked.
 - ▷  Call-up when the driver's door is opened.
 - ▷ **off**
Switch off automatic function.
- Press button **2**.
The setting is stored.

Malfunctions

The remote control may malfunction due to local radio waves. If this occurs, unlock and lock the car at the door lock with the integrated key.

Convertible: if hardtop movement via the remote control is interrupted briefly, the movement will be completed more quickly if you keep the corresponding button pressed continuously.

If the car can no longer be locked with a remote control, the battery in the remote control is discharged. Use the remote control on an extended trip to recharge the battery, refer to page 24. The remote control for Comfort Access contains a battery that may have to be changed, refer to page 35.

For US owners only

The transmitter and receiver units comply with part 15 of the FCC/Federal Communications Commission regulations. Operation is governed by the following:

FCC ID:
LX8766S
LX8766E
LX8CAS

Compliance statement:

This device complies with part 15 of the FCC Rules. Operation is subject to the following two conditions:

- ▷ This device must not cause harmful interference, and
- ▷ this device must accept any interference received, including interference that may cause undesired operation.

 Any unauthorized modifications or changes to these devices could void the user's authority to operate this equipment. ◀

Opening and closing: Using the door lock

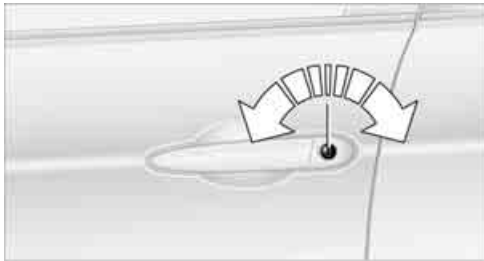

 Do not lock the vehicle from the outside if there is any person inside, because the vehicle cannot be unlocked from inside without special knowledge. ◀

With Comfort Access, you can set how the vehicle is unlocked, refer to page 25.

Convenient opening and closing

Coupe: you can operate the windows and the glass sunroof via the door lock.

Convertible: you can operate the windows and the retractable hardtop via the door lock.

Hold the key in the position for unlocking or locking.

 During each closing procedure, and when opening the retractable hardtop, watch the process and ensure that no one becomes trapped. Releasing the key stops the operation. ◀

Manual operation

In the event of an electrical malfunction, you can lock and unlock the driver's door by turning the integrated key to the corresponding limit positions in the door lock.

Opening and closing: From inside

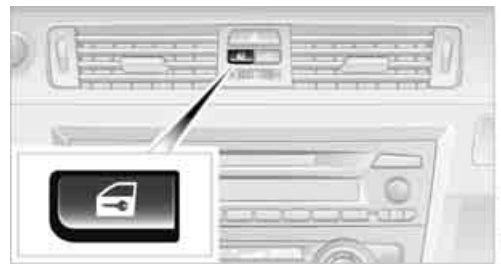

This button serves to unlock or lock doors and the trunk lid, but does not activate the anti-theft system. Depending on the equipment package, the fuel filler flap can be unlocked as needed.

Automatic locking

You can also set the situations in which the car locks:

For operating principle, refer to page 82.

1. Switch on the ignition, refer to page 57.
2. Briefly press button **1** in the turn signal/high beam lever up or down repeatedly until the symbol appears in the display, accompanied by the word "SET".



3. Press button **2**.
4. Briefly press button **1** in the turn signal/high beam lever down repeatedly until the symbol appears in the display.



5. Press button **2**.
6. Use button **1** to select:
 - ▷ **→ on**
The central locking system automatically locks the vehicle after some time if no door has been opened.

- ▷ **→ on**
The central locking system automatically locks the vehicle as soon as you drive off.
 - ▷ **🕒→**
The central locking system automatically locks the vehicle after some time if no door has been opened, or as soon as you drive off.
 - ▷ **off**
The central locking system remains unlocked.
7. Press button **2**.
The setting is stored for the remote control currently in use.

Unlocking and opening doors

- ▷ Either unlock the doors together using the button for the central locking system and then pull the door handle above the armrest or
- ▷ pull on the door handle of each door twice: the first time unlocks the door, the second time opens it.

Locking

- ▷ Use the central locking button to lock all of the doors simultaneously, or
- ▷ press down the safety lock button of a door. To prevent you from being locked out, the open driver's door cannot be locked using the lock button.



Persons or animals in a parked vehicle could lock the doors from the inside. You should therefore take the remote control with you when you leave the vehicle so that the latter can be opened from outside. ◀

Trunk lid

 In order to avoid damage, make sure there is sufficient clearance before opening the trunk lid. ◀

Opening from inside



Press the button: the trunk lid opens unless it has been locked.

Opening from outside



Press the button, see arrow, or the  button on the remote control for a longer period. The trunk lid will open slightly. It can now be swung upwards.

Coupe: locking or unlocking separately

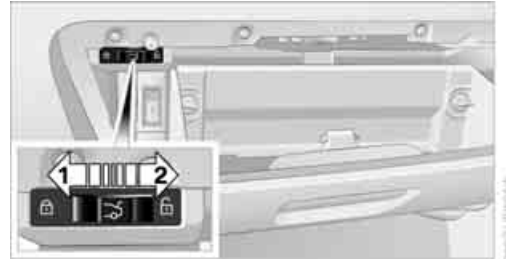

The switch is located in the glove compartment.

- 1 Locking the trunk lid
- 2 Unlocking the trunk lid

Locking separately

Push the switch in the direction of arrow 1. The trunk lid is locked and cannot be unlocked using the central locking system.

If you give the remote control without the integrated key to someone else while the glove compartment is locked, the trunk lid cannot be opened. This is an advantage when valet parking, for example. Locking the glove compartment, refer to page 120.

Unlocking separately

Push the switch in the direction of arrow 2.

Emergency release



Pull the lever in the cargo area. The trunk lid is unlocked.

Closing

The handle recesses on the interior trim of the trunk lid make it easier to pull down.

 Make sure that the closing path of the trunk lid is clear; otherwise, injuries may result. ◀

Coupe



Convertible

 To close the trunk lid, press it down lightly. The lid is closed automatically. ◀



Alarm system

The concept

The vehicle alarm system responds:

- ▷ When a door, the hood or the trunk lid is opened
- ▷ To movements inside the vehicle: Interior motion sensor, refer to page 33
- ▷ When the car's inclination changes, for instance if an attempt is made to jack it up and steal the wheels or to raise it prior to towing away

- ▷ When there has been an interruption of power supply from the battery

The alarm system signals unauthorized entry attempts for a short time by means of:

- ▷ An acoustic alarm
- ▷ Switching on the hazard warning flashers
- ▷ Flashing the high beams

Arming and disarming

General information

When you lock or unlock the vehicle, either with the remote control or at the door lock, the alarm system is armed or disarmed at the same time.

Door lock with armed alarm system

In some national-market versions, unlocking via the door lock triggers the alarm.

To switch off this alarm, unlock the vehicle with the remote control or switch on the ignition.

Trunk lid with the alarm system armed

The trunk lid can be opened via the remote control even when the alarm system is armed.

Press the  button on the remote control for approx. 1 second.

The trunk lid is locked and monitored again as soon as it is closed.

Panic mode

You can trigger the alarm system if you find yourself in a dangerous situation:

Press the  button for at least three seconds.

To switch off the alarm: press any button.

Switching off an alarm

- ▷ Unlock the car with the remote control, refer to page 25.
- ▷ Insert the remote control all the way into the ignition lock.

Indicator lamp on inside mirror



- ▷ The indicator lamp flashes continuously: The system is armed.
- ▷ The indicator lamp flashes after locking: The doors, hood, or trunk lid are not properly closed, the remaining components are secured. Then the indicator lamp flashes continuously after approx. 10 seconds. The interior motion sensor and tilt sensor are not active.
- ▷ The indicator lamp goes out after unlocking: The vehicle has not been tampered with.
- ▷ If the indicator lamp flashes after unlocking until the remote control is inserted in the ignition, but for no longer than approx. 5 minutes: The vehicle has been tampered with.

Tilt alarm sensor

The tilt of the vehicle is monitored. The alarm system reacts, e.g. to attempts to steal a wheel or tow the vehicle.

Interior motion sensor

Coupe

For proper function, the windows and glass sunroof must be closed.

Convertible

The interior of the car is monitored up to the height of the seat cushions. Thus the alarm system is activated together with the interior motion sensor even if the hardtop is open. The alarm can be triggered unintentionally by falling

objects such as leaves, refer to Avoiding unintentional alarms.

Avoiding unintentional alarms

The tilt sensor and interior motion sensor can be deactivated together, for example in the following situations:

- ▷ In car washes
- ▷ In stacking garages
- ▷ During transport on car-carrying trains, boats/ships or on a trailer
- ▷ When leaving animals in the vehicle

Switching off tilt alarm sensor and interior motion sensor

Once the vehicle is locked, press the  LOCK button on the remote control again within approx. 10 seconds.

The indicator lamp lights up briefly and then flashes continuously. The tilt alarm sensor and the interior motion sensor are switched off until the next time the vehicle is unlocked and subsequently locked again.

Comfort Access

The concept

It is possible to access the vehicle without actuating the remote control. It is sufficient to have the remote control with you, for example in your jacket pocket. The vehicle automatically detects the remote control in the vicinity or in the passenger compartment.

Comfort Access supports the following functions:

- ▷ Unlocking/locking the vehicle
- ▷ Convenient closing
- ▷ Unlocking the trunk lid separately
- ▷ Engine starting

Functional requirement

- ▷ There are no external sources of interference in the vicinity.
- ▷ The remote control must be outside the vehicle to lock it.
- ▷ The next unlocking and locking cycle is not possible until after approx. 2 seconds.
- ▷ It is only possible to start the engine if the remote control is inside the vehicle.

Comparison to the standard remote control

The above functions can be controlled by pressing the remote control buttons or by using Comfort Access.

 If you notice a brief delay while opening or closing windows, the glass roof or retractable hardtop, the system is checking whether a remote control is inside the vehicle. Please repeat the opening or closing procedure, if necessary. ◀

Unlocking

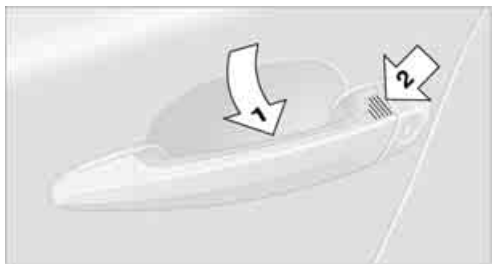

Grasp the handle on the driver's or front passenger door completely, arrow **1**. This corresponds to pressing the  button.

Locking

Touch the surface on the door handle, arrow **2**, with your finger for approx. 1 second. This corresponds to pressing the  LOCK button.

 To preserve the battery, please make sure that the ignition and all electrical consumers are switched off before locking the vehicle. ◀

Coupe: convenient closing

Keep pressing the surface, arrow **2**, with your finger.

Convertible: window and convertible top operation

With the ignition at radio readiness or beyond, you can open and close the windows and the convertible top when a remote control is located inside the vehicle.

Unlocking the trunk lid separately

Press the button on the outside of the trunk lid. This corresponds to pressing the  button.

 If the vehicle detects that a remote control has been accidentally left inside the locked vehicle's cargo area after the trunk lid is closed, the lid will reopen. The hazard warning flashers flash and a signal sounds. ◀

Switching on radio readiness

Pressing the Start/Stop button switches on radio readiness.

Do not depress the brake or the clutch; otherwise, the engine will start immediately.

Starting the engine

The engine can be started or the ignition can be switched on when a remote control is inside the vehicle. It is not necessary to insert a remote control into the ignition lock, refer to page [57](#).

Switching off the engine in cars with automatic transmission

The engine can only be switched off when the selector lever is in position P, refer to page 59. To switch the engine off when the selector lever is in position N, the remote control must be in the ignition lock.

Malfunction

Local radio waves can interfere with the function of Comfort Access, for example when a mobile phone is in the immediate vicinity of the remote control or by when a mobile phone is being charged in the vehicle.

If this happens, open or close the vehicle via the buttons on the remote control or using the integrated key. To start the engine afterward, insert the remote control into the ignition lock.

Warning lamps



The warning lamp in the instrument cluster lights up when you attempt to start the engine: the engine cannot be started. The remote control is not inside the vehicle or is malfunctioning.

Take the remote control with you inside the vehicle or have it checked. If necessary, insert another remote control into the ignition lock.



The warning lamp in the instrument cluster lights up while the engine is running: the remote control is no longer inside the vehicle. After the engine is switched off, the engine can only be restarted within approx. 10 seconds.



The indicator lamp in the instrument cluster lights up: replace the battery in the remote control.

Replacing the battery

The remote control for Comfort Access contains a battery that will need to be replaced from time to time.

1. Take the integrated key out of the remote control, refer to page 24.



2. Remove the cover.
3. Insert the new battery with the plus side facing up.
4. Press the cover on to close.



- Dispose of the old battery at a collection point or at your BMW center. ◀

Windows



To prevent injuries, watch the windows while closing them.

Take the remote control with you when you leave the car; otherwise, children could operate the electric windows and possibly injure themselves. ◀

Coupe: opening, closing

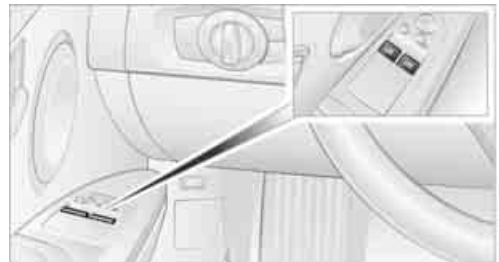

- ▷ Press the switch to the resistance point: The window opens as long as you press the switch.
- ▷ Press the switch beyond the resistance point: The window opens automatically. Press the switch again to stop the opening movement.

You can close the windows in the same manner by pulling the switch.

Convertible: opening, closing

Individually



- ▷ Press the switch to the resistance point:
The window opens as long as you press the switch.
- ▷ Press the switch beyond the resistance point:
The window opens automatically. Press the switch again to stop the opening movement.

You can close the windows in the same manner by pulling the switch. The rear windows do not close automatically.

Jointly

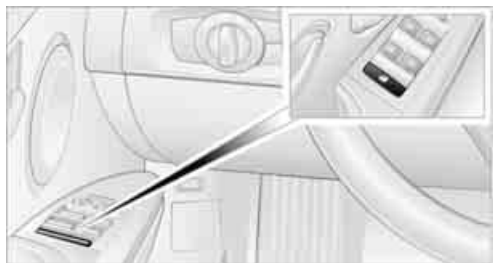

- ▷ Press the switch to the resistance point:
All windows open as long as you press the switch.

- ▷ Press the switch beyond the resistance point:
All windows open automatically. Press the switch again to stop the opening movement.
- ▷ Pull the switch:
All windows close as long as you pull the switch.

After switching off the ignition

When the remote control is removed or the ignition is switched off, you can still operate the windows for approx. 1 minute as long as no door is opened.

Convenient opening and closing

For information on Convenient opening and closing via the remote control or the door lock, refer to page 25 or 29. For information on Convenient closing with Comfort Access, refer to Locking on page 26.

Pinch protection system

If the closing force exceeds a specific value as a window closes, the closing action is interrupted and the window reopens slightly.



Despite the pinch protection system check and clear the window's travel path prior to closing it; otherwise, the safety system might fail to detect certain kinds of obstructions, such as thin objects, and the window would continue closing.

Do not install any accessories that might interfere with window movement. Otherwise, the pinch protection system could be impaired. Convertible: the rear windows are not equipped with pinch protection. Therefore, watch them closely when closing to avoid personal injury. ◀

Closing without pinch protection

If there is an external danger, or if ice on the windows, etc., prevents you from closing the windows normally, proceed as follows:

1. Pull the switch past the resistance point and hold it there. Pinch protection is limited and the window reopens slightly if the closing force exceeds a certain value.
2. Pull the switch again past the resistance point within approx. 4 seconds and hold it there. The window closes without pinch protection.

Coupe: Glass roof, electric

 To prevent injuries, watch the glass roof while closing it.

Take the remote control with you when you leave the car; otherwise, children could operate the roof and possibly injure themselves. ◀



Tilting

Press the switch.

- ▷ The closed glass roof is tilted and the sliding visor opens slightly.

Opening, closing

- ▷ Push the switch rearward to the resistance point:
The glass roof and the sliding visor open together as long as you hold the switch in this position.
- ▷ Push the switch rearward past the resistance point:
The glass roof and the sliding visor open automatically. Briefly press the switch again to stop the opening movement.

You can close the glass roof in a similar manner by pressing the switch forwards. The sliding visor remains open and can be closed by hand. For information on Convenient opening and closing via the remote control or door lock, refer to page 25 or 29.

After switching off the ignition

When the remote control is removed or the ignition is switched off, you can still operate the roof for approx. 1 minute as long as no door has been opened.

Pinch protection system

If the glass roof encounters an obstruction during closing from approximately the middle of the opening in the roof, or during closing from the tilted position, the closing movement is interrupted and the glass roof is opened again slightly.

 Despite the pinch protection system check and clear the roof's travel path prior to closing it; otherwise, the safety system might fail to detect certain kinds of obstructions, such as very thin objects, and the roof would continue closing. ◀

Closing without pinch protection

If there is an external danger, press the switch forward past the resistance point. The roof closes without pinch protection.

Following interruptions in electrical power supply

After a power failure, there is a possibility that the glass roof can only be tilted. The system must be initialized. BMW recommends having this work performed by your BMW center.

Closing manually

In the event of an electrical malfunction, you can move the glass roof manually:

1. Unclip the front of the cover of the interior lamps using the screwdriver from the onboard vehicle tool kit, refer to page 208.



2. Insert the screwdriver into the openings on each side to press the clips.



3. Remove the control unit.
4. Unplug the motor. Considerably less effort will be required for manual operation.

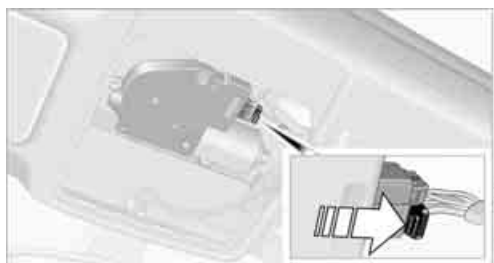

5. Insert the Allen wrench supplied with the onboard vehicle tool kit, into the opening provided. Move the glass roof in the desired direction.



6. Reinstall the control unit and reattach the lamp cover.

Convertible: retractable hardtop

The retractable hardtop combines reliable weather protection with simple and convenient operation.

The following tips will enhance your driving pleasure in your Convertible:

- ▷ It is advisable that you close the retractable hardtop when you park the vehicle. Not only does the closed hardtop protect the vehicle interior against unanticipated weather damage, it also offers theft protection. However, even when the hardtop is closed, valuables should only be stored in the locked cargo area.
- ▷ Do not attach roof rack systems to the retractable hardtop, and in particular do not attach magnetic racks.
- ▷ Do not attach rack systems to the trunk lid, and in particular do not attach magnetic racks.
- ▷ When the retractable hardtop is operated, the trunk lid swings back and up. Before operating the retractable hardtop, ensure that there is enough clearance, e.g. when parked in front of a wall.
- ▷ If you open the hardtop while it is wet, e.g. after driving in the rain, water may drip into the cargo area. If necessary, remove items from the cargo area beforehand to avoid water stains or soiling.

! Do not place any objects on the retractable hardtop or on the trunk lid; otherwise, they could fall during movements of the retractable hardtop and cause damage or injury. Never move the retractable hardtop when the rollover protection system is in the activated position.

Driving when the hardtop is not fully opened or closed may result in damage or injury. Do not reach into the mechanism during the opening or closing procedure. Keep children away from the swiveling area of the retractable hardtop. ◀

▷ The retractable hardtop cannot be moved at temperatures below +14 °F / -10 °C. ◀

! The retractable hardtop can only be opened and closed when the vehicle is stationary. To avoid causing damage, do not drive off until the hardtop has stopped moving. ◀

Before opening and closing

- ▷** Comply with the safety precautions described above.
- ▷** Ensure that the cargo area partition is folded down and engaged on both sides, refer to page 124; otherwise, it will not be possible to open the retractable hardtop.
- ▷** Do not place any objects next to or on the cargo area partition and close the storage compartment on the left side of the cargo area.
- ▷** Do not exceed the maximum loading height under the cargo area partition; refer to the label in the cargo area showing a line indicating the maximum height.
- ▷** Ensure that the trunk lid is closed.
- ▷** The vehicle should be parked on fairly level ground. Excessive angle is indicated by a lamp.

! Before moving the hardtop, make sure that there are no objects on or next to the cargo area partition, the storage compartment on the left side of the cargo area is closed, and

the maximum loading height in the cargo area has not been exceeded; otherwise, damage may occur. ◀

Opening and closing

When the vehicle is stationary and at radio readiness or beyond, refer to page 57:

▷ If possible, conserve the battery by only operating the retractable hardtop when the engine is running.

Before closing the retractable hardtop, remove all foreign objects from the windshield frame as these could prevent the hardtop from closing properly. ◀



1 Push button: open the retractable hardtop.
Pull button: close the retractable hardtop.

2 LEDs

▷ The side windows move down when the switch for hardtop operation is pulled or pushed. ◀

LEDs

- ▷** While the hardtop is being operated, the left LED lights up green. It goes out as soon as the top is fully opened or closed.
- ▷** If the right-hand LED flashes red when you release the switch, the opening or closing action has not yet finished.
- ▷** If the right LED lights up red when the switch is pressed, the cargo area partition is folded up, the trunk lid is not closed, the vehicle is standing on a strong incline or there is a malfunction. The retractable hardtop cannot be moved.

Interruption

The automatic sequence of movements is interrupted if the switch for hardtop operation is released. The sequence can be continued in the desired direction by pushing or pulling the switch.

 A hardtop that is not fully opened or closed is a safety hazard. Do not interrupt and resume the closing procedure several times in close succession as this could damage the mechanism. ◀

 If the hardtop is not fully opened or closed, the trunk lid cannot be opened and the windows cannot be moved. ◀

Convenient opening and closing with remote control or via door lock

Refer to pages 26 and 29.

Wind deflector

The wind deflector keeps air movements in the passenger compartment to a minimum when the hardtop is open and provides an even more comfortable ride, particularly at high speeds.

Installation

The wind deflector is stored in a protective cover in the cargo area. Brief instructions for operation can be found on the protective cover.

1. Remove the wind deflector from the protective cover and unfold it, arrows 1.

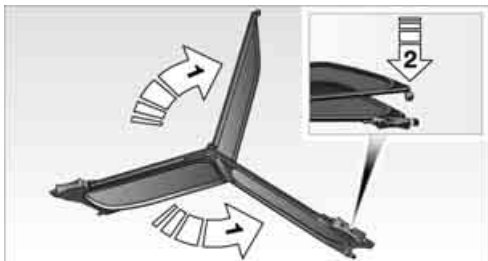

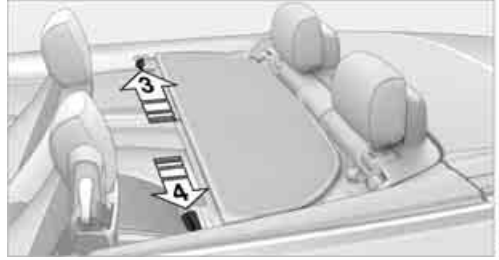

2. Press together the top and bottom parts of the wind deflector until the catch engages, arrow 2.



3. Push the fastening pin, arrow 3, into the opening provided on the right side of the vehicle until it snaps into place. Remove the protective caps beforehand, if necessary.
4. Push the fastening pin, arrow 4, into the opening provided on the left side of the vehicle until it snaps into place.



5. Turn the rotary handle in the direction of arrow 5 as far as the first stop to insert the right fastening pin into the holders.
6. Turn the rotary handle in the direction of arrow 6 as far as the  symbol to insert the left fastening pin into the holders.
7. Fold up the top section of the wind deflector.

 With the wind deflector installed: do not recline the front-seat backrests too far if the seat is to be slid all the way back, as this would damage the wind deflector. ◀

! Only turn the rotary handle within the range between the two symbols; otherwise, the cable system inside the wind deflector could be damaged. ◀

Removing the wind deflector

Proceed in the reverse order as used for installation.

Protective caps are provided in the vehicle for the holders of the wind deflector.

Folding

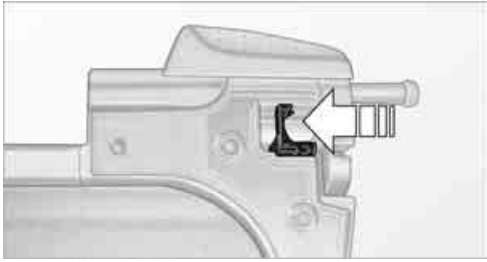



Slide the red release lever towards the middle of the wind deflector and push the two halves apart.

Loading function

Cargo can still be loaded on the rear seat of the vehicle even if the wind deflector has been installed.

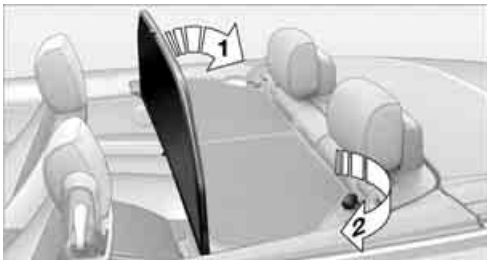
1. Lower all windows.
2. Fold down the top section of the wind deflector, arrow 1.



3. Turn the rotary handle to position , arrow 2.



Fold both sections of the wind deflector forward and rest them against the front seats, arrow 3.

To protect the seat cushions or to use the bag holders, you can fold the rear backrest down, refer to page 124.

Adjustments

Vehicle equipment

In this chapter, all production, country, and optional equipment that is offered in the model range is described. As a result, some equipment described may not be available in a particular vehicle, for example due to the options or national-market version selected. This also applies to safety related functions and systems.

Sitting safely

The ideal sitting position can make a vital contribution to relaxed, fatigue-free driving. In conjunction with the safety belts, the head restraints and the airbags, the seated position has a major influence on your safety in the event of an accident. To ensure that the safety systems operate with optimal efficiency, we strongly urge you to observe the instructions contained in the following section.

For additional information on transporting children safely, refer to page 53.

Airbags

 Always maintain an adequate distance between yourself and the airbags. Always grip the steering wheel on the rim, with your hands in the 3 o'clock and 9 o'clock positions, to minimize the risk of injury to the hands or arms in the event of the airbag being triggered off.

No one and nothing should come between the airbags and the seat occupant.

Do not use the cover of the front airbag on the front passenger side as a storage area. Make sure that the front passenger is sitting correctly, e.g. not resting feet or legs on the dashboard; otherwise, leg injuries can occur if the front airbag deploys.

Make sure that passengers keep their heads away from the side airbag and do not lean

against the cover of the head airbag; otherwise, serious injuries can result if the airbag deploys. ◀

Even if you follow all the instructions, injuries resulting from contact with airbags cannot be fully excluded, depending on the circumstances. The ignition and inflation noise may provoke a mild hearing loss in extremely sensitive individuals. This effect is usually only temporary.

For airbag locations and additional information on airbags, refer to page 99.

Head restraint

A correctly adjusted head restraint reduces the risk of neck injury in the event of an accident.

 Adjust the head restraint in such a way that its center is at approx. ear level. Otherwise, there is an increased risk of injury in the event of an accident. ◀

Head restraints, refer to page 45.

Safety belt

Before every drive, make sure that all occupants wear their safety belts. Airbags complement the safety belt as an additional safety device, but they do not represent a substitute.

Your vehicle has four seats, each of which is equipped with a safety belt.

 Never allow more than one person to wear a single safety belt. Never allow infants or small children to ride in a passenger's lap. Make sure that the belt in the lap area sits low across the hips and does not press against the abdomen.

The safety belt must not rest against the throat, run across sharp edges, pass over hard or fragile objects or be pinched. Fasten the safety belt so that it sits as snugly as possible against the lap and shoulder without being twisted. Otherwise, the belt could slide over your hips and

injure your abdomen in the event of a frontal collision.

Avoid wearing bulky clothing and regularly pull the belt in the upper-body area taut; otherwise, its restraining effect could be impaired. ◀

Safety belts, refer to page 49.

Seats

Note before adjusting

 Never attempt to adjust your seat while the vehicle is moving. The seat could respond with unexpected movement, and the ensuing loss of vehicle control could lead to an accident.

On the front passenger seat as well, do not incline the backrest too far to the rear while the vehicle is being driven; otherwise, there is a danger in the event of an accident of sliding under the safety belt, eliminating the protection normally provided by the belt. ◀

Comply with the instructions on head restraint height on page 45, and on damaged safety belts on page 49.

Manual adjustment

 Observe the adjustment instructions on page 43 to ensure the best possible personal protection. ◀

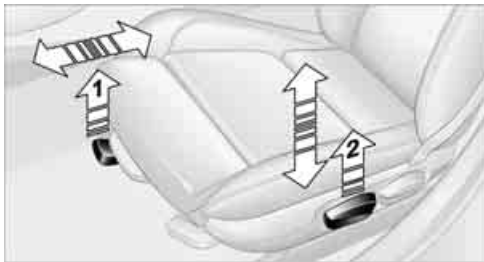

Longitudinal direction

Pull lever **1** and slide the seat to the desired position.

After releasing the lever, move the seat gently forward or back to make sure it engages properly.

Height

Pull lever **2** and apply your weight to the seat or lift it off, as necessary.

Backrest

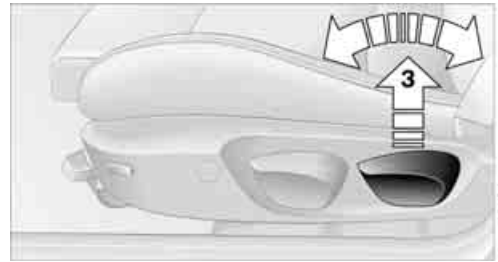

Pull lever **3** and apply your weight to the backrest or lift it off, as necessary.

Angle

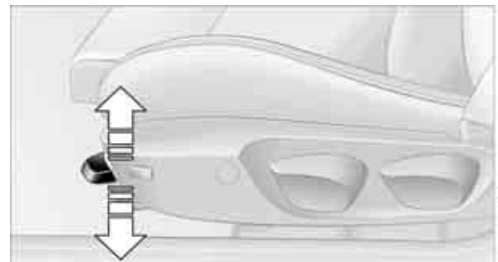

Pull the lever and apply your weight to the seat or lift it off, as necessary.

Thigh support

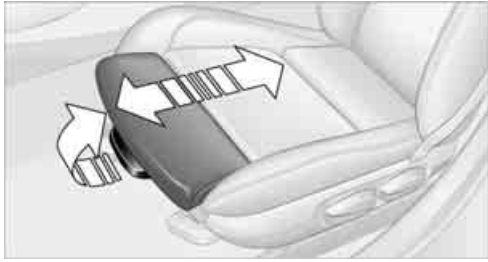

Pull the lever and move the thigh support forward or back.

Electrical adjustment



Observe the adjustment instructions on page 43 to ensure the best possible personal protection. ◀

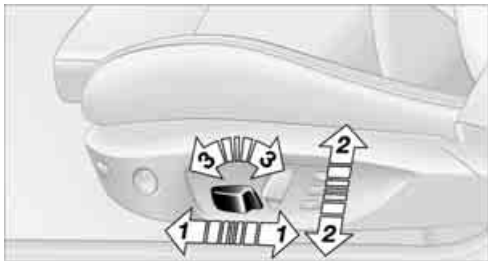

- 1 Longitudinal direction
- 2 Height
- 3 Angle

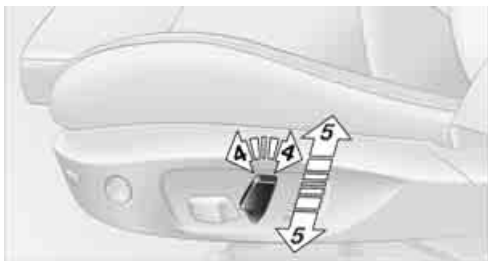

- 4 Backrest
- 5 Convertible: head restraints

Coupe: the head restraints are adjusted manually, refer to Head restraints below.

Lumbar support



You can also adjust the contour of the backrest to obtain additional support in the lumbar region.

The upper hips and spinal column receive supplementary support to help you maintain a relaxed, upright sitting position.

- ▷ Increase or decrease curvature: press the switch at the front or rear, respectively.
- ▷ Shift curvature up or down: press the switch at the top or bottom, respectively.

Backrest width



You can change the width of the backrest to suit your individual preferences by adjusting the lateral-support pads.

Press the front or rear end of the switch. Backrest width decreases or increases accordingly.

Longitudinal adjustment from outside/behind

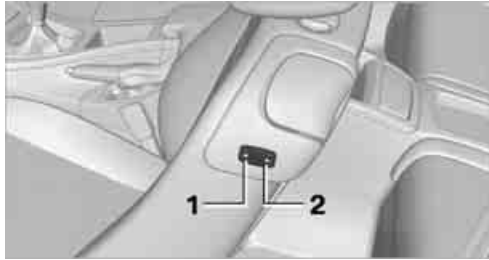

To move the front seats forward or backward from outside or from one of the rear seats: with the door open, press the front end **1** or rear end **2** of the switch.

Head restraints

Correctly adjusted head restraint

A correctly adjusted head restraint reduces the risk of neck injury in the event of an accident.

⚠ Correctly adjust the head restraints of all occupied seats; otherwise, there is an increased risk of injury in an accident. ◀

Height

Adjust the head restraint so that its center is approximately at ear level.

Distance

Adjust the distance so that the head restraint is as close as possible to the back of the head.

Front active head restraints

In a rear collision of a sufficient strength, the active head restraint reduces the distance to the head.

⚠ Do not use seat or head restraint covers that could impair the function of the active head restraint.

Do not hang any items, e.g. clothes hangers, directly on the head restraints. Attach only BMW approved accessories to the seat or head restraint.

Otherwise, the protective function of the active head restraint will not be ensured and its full potential in reducing the risk of injury in the event of a rear collision may not be realized. In the event of faults, immobilization, or after the active head restraints have been triggered, have the testing, repair, or disassembly performed only by your BMW center or a workshop that has the required explosives licenses. Unprofessional attempts to work on the system could lead to failure in an emergency or to undesired airbag activation, either of which could result in personal injury. ◀



For technical reasons, the head restraint cannot be removed. ◀

Coupe: front seats

Height adjustment

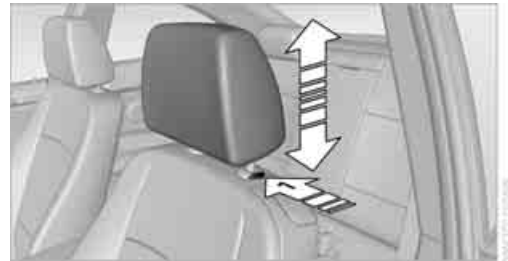

- ▷ To raise: pull up.
- ▷ To lower: press the button, arrow **1**, and slide the head restraint down.

Convertible: front seats

Height adjustment

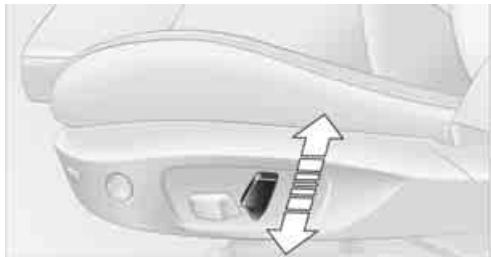

- ▷ To raise: press the button upward.
- ▷ To lower: press the button downward.

Adjusting the distance to the back of the head

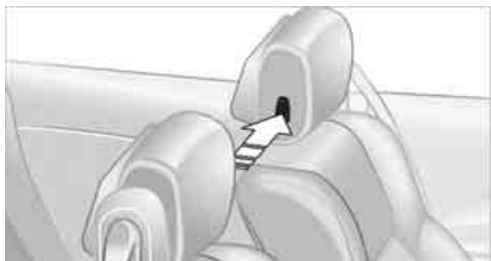

- ▷ Forward: pull up.
- ▷ Back: press the button and push the head cushion toward the rear.

! Do not insert objects behind the head cushion; otherwise, the head restraint may not function properly. ◀

Coupe: rear seats

Height adjustment

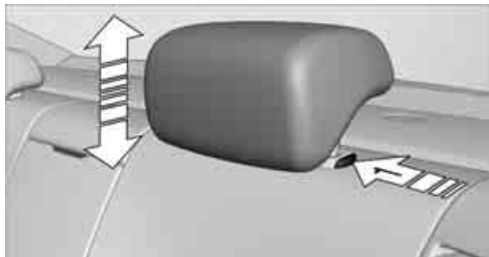

- ▷ To raise: pull up.
- ▷ To lower: press the button, arrow **1**, and slide the head restraint down.

Removing

Only remove a head restraint if no one will be sitting on the seat in question.

1. Pull up as far as it will go.
2. Press the button, arrow **1**, tilt the rear seat backrest slightly forward and pull the head restraint all the way out.

Entering the rear seats

Coupe: seat with manual longitudinal adjustment



Easy entry

The easy entry feature includes a memory function for the longitudinal adjustment and backrest angle.

1. Pull the lever and swing the backrest forward.
2. Push the seat forward.

Previous position

Push the seat backward and swing the backrest back.

! When pushing the seat into its rearmost position, make sure that no one is injured and that no objects are damaged. Before driving off, engage both seats and backrests so that they are locked in place. Otherwise, there is a risk of an accident due to unexpected movement. ◀

Seat with electrical longitudinal adjustment

Coupe

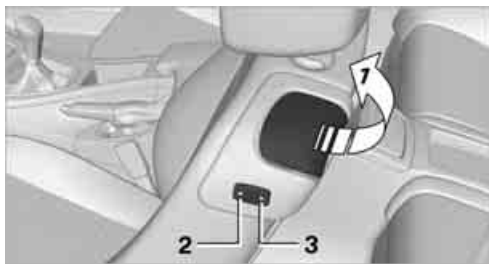

Convertible



Seat backrest warning lamp:
Lights up when a seat backrest is not engaged.

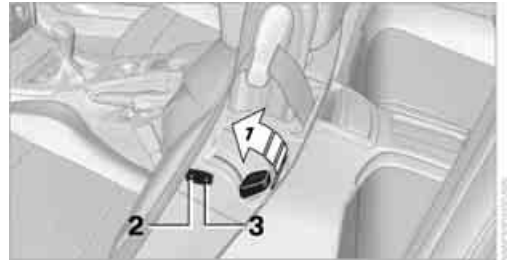

Easy entry

The easy entry feature includes a memory function for the longitudinal adjustment and backrest angle.

1. Pull lever **1** and swing the backrest forward.
2. Press the front end **2** of the switch until the seat has moved into the desired position.

Previous position

Press the rear end **3** of the switch until the seat automatically stops in its previous position, and fold the backrest back. If you release the switch before the previous seat position is reached, the seat will stop at its current position.

! When sliding the seat backward, make sure no one is injured and no objects are damaged.

Before driving off, engage both seats and backrests so that they are locked in place. Otherwise, there is a risk of an accident due to unexpected movement. ◀

Seat heating



Depending on the vehicle's equipment, press one of the buttons labeled **1** or **2** here.

Press the button once per temperature level. Three LEDs indicate the highest temperature.

To switch off:

Press button longer.

If you continue driving within approx. the next 15 minutes, the seat heating is automatically activated at the previously set temperature.

The temperature is lowered or the heating is switched off entirely to save on battery power. The LEDs stay lit.

Seat and mirror memory

You can store and call up two different combinations of driver's seat and exterior mirror positions.

Settings for the backrest width and lumbar support are not stored in memory.

Storing

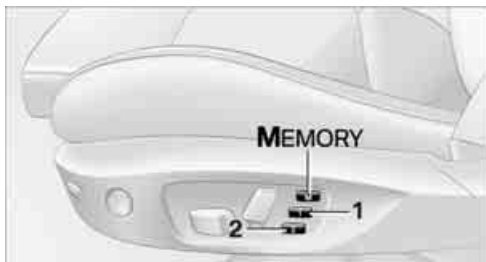

1. Switch on radio readiness or the ignition, refer to page 57.
2. Adjust the seat and exterior mirrors to the desired positions.
3. Press the **M** button. The LED in the button lights up.
4. Press the desired memory button **1** or **2**: the LED goes out.

The driver's seat and exterior mirror positions are stored for the remote control currently in use.

Call-up



Do not call up the memory while you are driving; otherwise, unexpected seat movement could result in an accident. ◀

Comfort function

1. Unlock and open the driver's door or switch on radio readiness, refer to page 57.
2. Briefly press the desired memory button **1** or **2**.

The adjusting procedure is halted immediately when you touch a seat adjustment switch or one of the memory buttons.

Safety feature

1. Close the driver's door and switch the ignition on or off, refer to page 57.
2. Press the desired memory button **1** or **2** and keep it pressed until the adjustment process has been completed.

If the **M** button was pressed accidentally: Press the button again; the LED goes out.

Safety belts

 Observe the adjustment instructions on page 43 to ensure the best possible personal protection. ◀

Before every drive, make sure that all occupants wear their safety belts. Airbags complement the safety belt as an additional safety device, but they do not represent a substitute.



Closing

Make sure you hear the latch plate engage in the belt buckle.

The upper belt anchor is suitable for adults of any stature as long as the seat is adjusted properly, refer to page 43.

Opening

1. Grasp the belt firmly.
2. Press the red button in the buckle.
3. Guide the belt into its reel.

"Fasten safety belts" reminder for driver's and front passenger seat



The indicator lamps light up and an acoustic signal sounds. Check whether the safety belt has been fastened correctly.

The 'Fasten safety belts' reminder is issued as long as the driver's safety belt has not been fastened. The "Fasten safety belts" reminder is also activated at road speeds above approx. 5 mph or 8 km/h if the front passenger safety belt is not fastened, if objects are placed on the front passenger seat, or if driver or front passenger unfasten their safety belts.

Damage to safety belts

 If the safety belts are damaged or stressed in an accident: have the belt system, including any belt tensioners or child restraint systems, replaced and the belt anchors checked. Have this work carried out only at your BMW center. Otherwise correct operation of this safety equipment is not guaranteed. ◀

Coupe: belt hand-over

The concept

The belt hand-over makes it easier for you to fasten your safety belt. When you close the door and switch on radio readiness or the ignition, the belt hand-over extends automatically and presents the in a position that is convenient for fastening it around you. After you have fastened your safety belt, the belt hand-over retracts to its original position.



Even if you have not yet fastened your safety belt, the belt hand-over will retract if you:

- ▷ Wait for more than approx. one minute
- ▷ Open the corresponding door
- ▷ Start driving.

Closing the respective door reactivates the belt hand-over if the ignition or radio readiness is on.

Front passenger seat

The belt hand-over will extend only if the seat is occupied and after the front passenger door is closed.

Pinch protection system

If the belt hand-over encounters resistance on moving in or out, it moves back slightly in the opposite direction and stops in this position. To reactivate the belt hand-over: open and close the door or switch the ignition off and on.

 Although there is a pinch protection system, always check that the maneuvering area of the belt hand-over is clear. Otherwise it cannot be ensured that the system will stop moving in certain extreme situations. ◀

Mirrors

Exterior mirrors

 The front passenger's mirror is more convex than the driver's mirror. The objects seen in the mirror are closer than they appear. Do not gauge your distance from traffic behind you on the basis of what you see in the mirror; otherwise, there is an increased risk of an accident. ◀

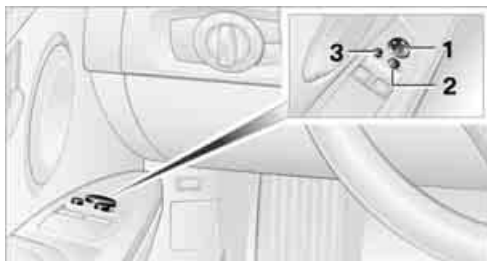

- 1 Adjustments
- 2 Switching to the other mirror or to the automatic curb monitor
- 3 Folding mirrors in and out

The setting for the exterior mirrors is stored for the remote control currently in use. The stored position is called up automatically when the vehicle is unlocked.

Manual adjustment

The mirrors can also be adjusted manually: press the edge of the glass.

Folding mirrors in and out

At driving speeds up to approx. 12 mph/20 km/h, you can fold the mirrors in and out by pressing button **3**. This can be beneficial in narrow streets, for example, or for moving mirrors that were folded in by hand back out into their correct positions. Mirrors that have been folded in fold out automatically at a speed of approx. 24 mph/40 km/h.

 Before entering an automatic car wash, fold in the exterior mirrors manually or with button **3** to prevent them from being damaged, depending on the width of the vehicle. ◀

Automatic heating

Depending on the outside temperature, both exterior mirrors are heated automatically when the engine is running or the ignition is switched on.

Passenger side mirror tilt function – automatic curb monitor

Activating

1. Push the switch to the position for the driver's side mirror, arrow **1**.

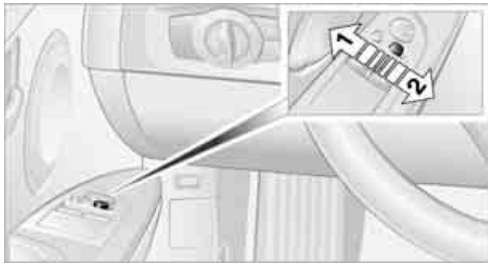

2. Shift into reverse or engage the selector lever- or transmission position R. The glass of the mirror on the passenger side tilts slightly down. This allows the driver to see the area immediately adjacent to the vehicle, e.g. a curb, when backing into a parking space.

Deactivating

Push the switch to the position for the passenger side mirror, arrow **2**.

Interior rearview mirror



Turn the knob to reduce glare from the headlights of cars behind you when driving at night.

Interior and exterior mirrors, automatic dimming feature

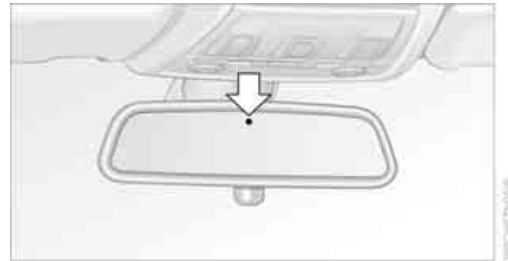

The automatic dimming feature of the interior and exterior mirrors is controlled by two photo cells in the interior rearview mirror. One photo cell is in the mirror frame, see arrow; the other is on the back of the mirror.

In order to ensure that the system functions correctly, keep the photo cells clean, do not cover the area between the interior rearview mirror and windshield, and do not affix adhesive labels or stickers of any kind to the windshield directly in front of the mirror.

Steering wheel

Adjustments

 Do not adjust the steering wheel position while the car is in motion; otherwise, there is a risk of an accident due to unexpected movement. ◀

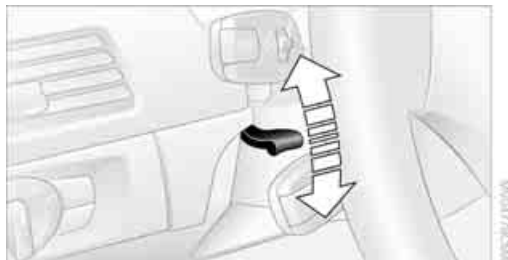

1. Fold the lever down.
2. Move the steering wheel to the preferred height and angle to suit your seated position.
3. Swing the lever back up.

 Do not use force to swing the lever back up; otherwise, the mechanism will be damaged. ◀

Steering wheel heating



Press the button.

The LED in the button lights up when the steering wheel heating is switched on.

Transporting children safely

Vehicle equipment

In this chapter, all production, country, and optional equipment that is offered in the model range is described. As a result, some equipment described may not be available in a particular vehicle, for example due to the options or national-market version selected. This also applies to safety related functions and systems.

The right place for children

 Do not leave children unattended in the vehicle; otherwise, they could endanger themselves and/or other persons by opening the doors, for example. ◀

Children always in the rear

Accident research has shown that the safest place for children is on the rear seat.

 Children under the age of 13 or smaller than 5 ft/150 cm may be transported only in the rear in suitable child restraint systems appropriate for their age, weight and size. Otherwise, there is an increased risk of injury in the event of an accident. ◀

Children 13 years of age or older must be buckled in with a safety belt as soon as there no longer is any child restraint system that is appropriate for their age, size and weight.

Children in the front passenger seat

 Should it be necessary to use a child restraint system on the front passenger seat, the front and side airbags for the front passenger must be deactivated. Otherwise, a child traveling on that seat will face a significant risk of injury if the airbags are triggered off, even with a child restraint system. ◀

For more information on automatic deactivation of the front passenger airbags refer to page 100.

Convertible: key switch for passenger belt



The passenger safety belt can be locked with a key switch so that it is prevented from being pulled out.



The key switch is situated on the side surface of the passenger-side dashboard.

Locking the passenger belt

Lock the passenger belt to install a child restraint system.

Insert key and push in.

Keep key pushed in and turn it until reaching the stop at the  position. Pull key out at this stop.

 After removing the key, make sure that the switch is in the  position; otherwise, the locking action on the safety belt is not guaranteed. ◀

Unlocking the passenger belt

If no child restraint system is fastened to the front passenger seat, unlock the passenger belt; otherwise, the freedom of movement of the upper body is limited.

Insert key and push in.

Keep key pushed in and turn it until reaching the stop at the  position. Pull key out at this stop.

 Make sure that the passenger belt is unlocked; otherwise, the front passenger may become trapped by the safety belt. ◀

Installing child restraint systems

 Observe the child restraint system manufacturer's instructions when selecting, installing and using child restraint systems. Otherwise, the protective effect may be diminished. ◀

Standard child restraint systems are designed to be secured with a lap belt or with the lap-belt section of a lap-and-shoulder belt. Incorrectly or improperly installed child restraint systems can increase the risk of injury to children. Always follow the installation instructions for the system with the greatest care.

On the front passenger seat

 After installing a child restraint system on the front passenger seat, make sure that the front and side airbags for the front passenger are deactivated; otherwise, there is an increased risk of injury if the airbags deploy. ◀

Seat position

Before installing a child restraint system, move the front passenger seat as far back and up as possible to obtain the best possible position for the belt. Do not change the seat position after this.

Backrest width

 The backrest width of the front passenger seat must be at its widest possible setting. Do not change the setting after installing the child seat; otherwise, the child seat's stability on the front passenger seat is limited. ◀

1. Adjust the backrest width to its widest setting, refer to page 44.
2. Install the child seat.

Child seat security



The rear safety belts and the front passenger safety belt can be prevented from being pulled out in order to fasten child restraint systems.

To lock the safety belt

1. Secure the child restraint system with the belt.
2. Pull the belt strap all the way out.
3. Allow the belt strap to retract and pull it taut against the child restraint system.

The safety belt is locked.

To unlock the safety belt

1. Open the belt buckle.
2. Remove the child restraint system.
3. Allow the safety belt strap to retract all the way.

LATCH child restraint fixing system

LATCH: Lower Anchors and Tethers for Children.

 To install and use the LATCH child restraint system, follow the operating and safety instructions provided by the manufacturer of the system; otherwise, the protective function of the seat may be compromised. ◀

Mounts for the lower LATCH anchors

Mounts for lower LATCH anchors

Before installing the child seat, pull the belt out of the area for the child restraint fixing system.

! Ensure that both lower LATCH anchors are correctly engaged and that the child restraint system is resting firmly against the backrest; otherwise, the protective function of the seat may be compromised. ◀



The mounts for the lower LATCH anchors are located behind the labeled protective caps.

Installing LATCH child restraint systems

- 1 Installing child restraint system, refer to the system operating instructions.
- 2 Make sure that both LATCH anchors are correctly locked in position.

Child restraint system with tether strap

Convertible

For Canadian Customers Only.

The following statement is required by Transport Canada.

This vehicle is not equipped with user-ready tether anchorages. As such neither a child restraint system, nor a booster cushion, requiring the use of a tether strap can be properly secured in the vehicle.

Coupe

! Use the tether strap anchors to secure child restraint systems only; otherwise, the anchors could be damaged. ◀

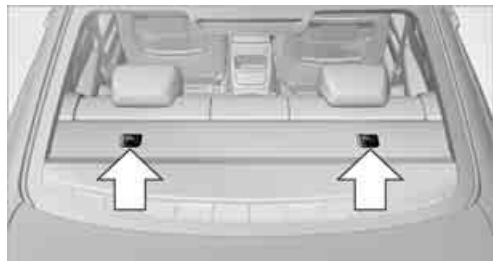

For child restraint systems with tether straps there are two additional anchors, see arrows.

Placement of the tether strap

Coupe

! Make sure the upper retaining strap does not run over sharp edges and is not twisted as it passes to the top anchor. Otherwise, the strap will not properly secure the child restraint system in the event of an accident. ◀

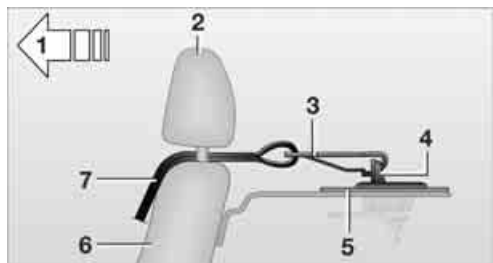

- 1 Direction of travel
- 2 Head restraint
- 3 Hook for upper retaining strap
- 4 Anchor
- 5 Rear window shelf
- 6 Seat backrest
- 7 Upper retaining strap of child restraint system

If necessary, fold the anchors upward before use.

1. Push the head restraint upward.
2. Guide the upper retaining strap between the head restraint holders.
3. Use the hook to clip the retaining strap to the anchor.
4. Push the head restraint into its lowermost position.
5. Pull the retaining strap taut.

Driving

Vehicle equipment

In this chapter, all production, country, and optional equipment that is offered in the model range is described. For this reason, descriptions will be given of some equipment that may not be available in a vehicle, for example due to the special options or national-market version selected. This also applies to safety related functions and systems.

Ignition lock

Insert the remote control into the ignition lock



Insert the remote control all the way into the ignition lock.

- ▶ Radio readiness is switched on.
Individual electrical consumers can operate.

Comfort Access

If the car is equipped with Comfort Access, only insert the remote control into the ignition lock under special circumstances, refer to page 33.

Removing the remote control from the ignition lock

 Do not forcibly pull the remote control out of the ignition lock as this may cause damage. ◀

Before removing the remote control, push it all the way in to release the locking mechanism.

- ▶ The ignition is switched off if it was on.

Automatic transmission

You cannot take out the remote control unless the selector lever is in the P position: interlock.

Start/Stop button



Pressing the Start/Stop button switches radio readiness or the ignition on or off.

- ▶ Manual transmission: when you press the Start/Stop button and depress the clutch, the engine starts.

Automatic transmission and Sport automatic transmission with double clutch: when you press the Start/Stop button and depress the brake pedal, the engine starts. ◀

Radio readiness

Individual electrical consumers can operate. The time and the outside temperature are displayed in the instrument cluster.

Radio readiness is switched off automatically:

- ▶ When the remote control is removed from the ignition lock
- ▶ In cars with Comfort Access, by touching the surface above the door lock, refer to Locking on page 34

Ignition on

All electrical consumers can operate. The odometer and trip odometer are displayed in the instrument cluster.

 When the engine is off, please switch off the ignition and any unnecessary electrical consumers in order to preserve the battery. ◀

Radio readiness and ignition off

All indicator and warning lamps as well as displays in the instrument cluster go out.

Starting the engine

 Do not run the engine in enclosed areas; otherwise, the inhalation of toxic exhaust gases can cause loss of consciousness and death. The exhaust gases contain carbon monoxide, an odorless and colorless, but highly toxic gas. Never leave an unattended vehicle with the engine running; otherwise, such a vehicle represents a potential safety hazard. Before leaving the vehicle with the engine running, always shift into neutral or selector lever/ transmission position P and apply the parking brake forcefully to prevent the vehicle from rolling. ◀

 Avoid frequent starting in quick succession as well as repeated start attempts in which the engine does not start. Otherwise, the fuel is not burned or incompletely burned and there is a danger of overheating and damaging the catalytic converter. ◀

Do not wait for the engine to warm up while the vehicle remains stationary. Start driving right away, but at moderate engine speeds.



Manual transmission

Remote control in the ignition lock or, with Comfort Access, inside the vehicle, refer to page 33.

1. Depress the brake.
2. Depress the clutch and shift into neutral.
3. Press the Start/Stop button.

The starter operates automatically for a certain time, and stops automatically as soon as the engine has started.

Automatic transmission

Remote control in the ignition lock or, with Comfort Access, inside the vehicle, refer to page 33.

1. Depress the brake.
2. Move the selector lever to position P.
3. Press the Start/Stop button.

The starter operates automatically for a certain time, and stops automatically as soon as the engine has started.

Sport automatic transmission with double clutch

Remote control in the ignition lock or, with Comfort Access, inside the vehicle, refer to page 33.

1. Depress the brake.
2. Press the Start/Stop button.

The engine starts independent of the current transmission position.

Switching off the engine

 Always take the remote control with you when you leave the vehicle.

When parking, apply the parking brake forcefully; otherwise, the vehicle could begin to roll. ◀

Manual transmission

1. With the car at a standstill, press the Start/Stop button.
2. Shift into first gear or reverse.
3. Forcefully apply the parking brake.
4. Removing the remote control from the ignition lock, refer to page 57.

Automatic transmission

1. With the car at a standstill, move the selector lever to position P.
2. Press the Start/Stop button.
3. Forcefully apply the parking brake.
4. Removing the remote control from the ignition lock, refer to page 57.

Sport automatic transmission with double clutch

1. With the car at a standstill, press the Start/Stop button.
If the transmission is shifted into N when the engine is switched off, you will be notified visually and acoustically of this fact.
2. Forcefully apply the parking brake.
3. Remove remote control from the ignition lock, refer to page 57. The transmission is automatically shifted into transmission position P.

Parking brake

The parking brake is primarily intended to prevent the vehicle from rolling while parked; it brakes the rear wheels.

Indicator lamp



The indicator lamp is lit, and when you drive off an acoustic signal sounds in addition. The parking brake is still applied.



Indicator lamp for Canadian models.

Applying

The lever locks in position automatically.

Releasing

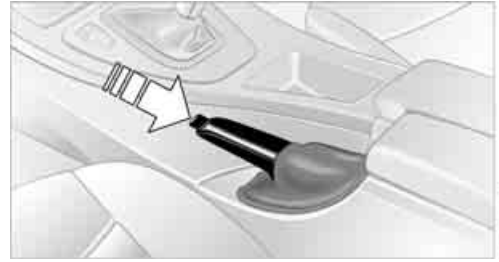

Pull slightly upwards, press the button and lower the lever.



In exceptional cases, if the parking brake has to be used to slow or stop the car, do not pull the lever up too hard. In doing so, continuously press the button of the parking brake lever.

Otherwise, excessive force on the parking brake can lock up the rear wheels and cause the rear of the car to swerve. ◀



To prevent corrosion and one-sided braking action, occasionally apply the parking brake lightly when the vehicle is slowly coming to a stop if the traffic conditions are suitable. The brake lamps do not light up when the parking brake is applied. ◀

Manual transmission



⚠ When shifting into 5th or 6th gear, press the gearshift lever to the right. Otherwise, the engine could be damaged if you inadvertently shift into 3rd or 4th gear. ◀

Reverse gear

Select this only when the vehicle is stationary. When the gearshift lever is pressed to the left, a slight resistance has to be overcome.

Automatic transmission with Steptronic

In addition to fully automatic operation, you can also manually shift with the Steptronic, refer to page 61.

Vehicle parking

⚠ To prevent the vehicle from rolling, always select position P and apply the parking brake before leaving the vehicle with the engine running. ◀

Disengaging the remote control

In order to remove the remote control from the ignition lock, you must first move the selector lever to position P and switch off the engine: interlock. Removing the remote control from the ignition lock, refer to page 57.

Selector lever positions

P R N D M/S + -

Displays in the instrument cluster



The selector lever position is displayed and, in manual mode, the engaged gear, e.g. M4.

Changing selector lever positions

- ▶ With the ignition switched on or the engine running, the selector lever can be moved out of position P.
- ▶ Before moving the lever away from P or N with the vehicle stationary, first depress the brake; otherwise, the selector lever will refuse to move: shiftlock.

⚠ To prevent the vehicle from creeping after you select a driving position, depress the brake until you are ready to start. ◀



A lock prevents you from inadvertently engaging selector lever positions R and P. To cancel the lock, press the button on the front of the selector lever, see arrow.

P Park

Select this only when the vehicle is stationary. The rear wheels are locked.

R Reverse

Select this only when the vehicle is stationary.

N Neutral

You can select this in a car wash, for example. The vehicle can roll.

D Drive, automatic position

Position for normal vehicle operation. All forward gears are selected automatically.

Under normal operating conditions, fuel consumption is lowest when you are driving in position D.

Kickdown

Kickdown enables you to achieve maximum performance.

Press the accelerator pedal beyond the full-throttle resistance point.

Sport program and manual mode M/S



Move selector lever from position D toward the left into the M/S shifting slot; the Sport program is activated. This position is recommended for a performance-oriented driving style.

DS is displayed in the instrument cluster.

To deactivate the sport program or manual mode M/S, move the selector lever to the right into position D.

Shifting gears via the selector lever

Move selector lever from position D toward the left into the M/S shifting slot:

When you press the selector lever forwards or backwards, the manual mode is activated and Steptronic changes gear.

The engaged gear, e.g. M1 is displayed in the instrument cluster.

Upshifts and downshifts are executed only when they will result in a plausible combination of engine and vehicle speed; thus, for example, a downshift that would cause the engine to overrev will not be executed by the system.

The gear selected is briefly displayed in the instrument cluster, followed again by the gear actually in use.

Changing gears using shifting paddles on steering wheel

The shift paddles allow you to shift gears quickly since both hands can remain on the steering wheel.

- ▷ When you use the shift paddles on the steering wheel to shift gears in automatic mode, the transmission switches to manual mode.
- ▷ If you do not accelerate or shift gears using the shift paddles for a certain amount of time, the transmission switches back to automatic mode.
- ▷ If the selector lever is in the M/S gear plane, manual mode remains active. ◀

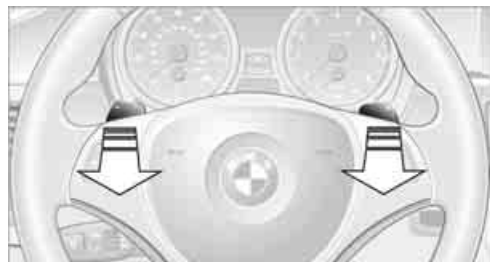

- ▷ To upshift, briefly pull the right shift paddle +.
- ▷ To downshift, briefly pull the left shift paddle -.

Upshifts and downshifts are executed only when they will result in a plausible combination of engine and vehicle speed; thus, for example, a downshift that would cause the engine to overrev will not be executed by the system.

The gear selected is briefly displayed in the instrument cluster, followed again by the gear actually in use.

Overriding selector lever lock

Should the selector lever refuse to move out of position P even though the ignition is switched on, the brake is depressed and the button on the selector lever is pressed, the selector lever lock can be overridden:

1. Switch off ignition.
2. Unclip the sleeve of the selector lever.
3. Pull the sleeve up over the selector lever until the sleeve is inside out.



4. Using the screwdriver from the onboard vehicle tool kit, refer to page 208, press the red lever and with the button pressed, simultaneously move the selector lever to the desired position.

7-gear Sport automatic transmission with double clutch

The concept

The 7-gear Sport automatic transmission with double clutch is an automated manual transmission with two clutches and secondary gear

sets in which the clutching and shifting is handled by an electrohydraulic system.

With the 7-gear Sport automatic transmission with double clutch, the gears are shifted without an interruption in driving power.

You operate the 7-gear Sport automatic transmission with double clutch using the selector lever and two shift paddles on the steering wheel.

It offers you the following functions:

- ▷ Either manual or automatic mode: sequential mode or drive mode
- ▷ Automatic downshifting and protection against incorrect gear selection, even in sequential mode
- ▷ Acceleration assistant, Launch Control, refer to page 66
- ▷ Automatic intermediate throttle application

System limitations

The 7-gear Sport automatic transmission with double clutch has an overheating protection that protects the clutch from extreme loads.



The indicator lamp lights up in yellow if the transmission becomes too warm.

Avoid high engine loads and frequent accelerations from zero. If the transmission is overheated, the indicator lamp lights up in red and the power flow to the motor is interrupted. It is only possible to continue driving once the transmission has cooled down.

Avoid frequent powerful accelerations from zero and do not hold the vehicle on inclines by pressing lightly on the accelerator while letting the clutch slip, as this may cause the transmission to overheat.

Selector lever positions

P R N D M/S + -

Displays in the instrument cluster



The selector lever position and the engaged gear are displayed, e.g. M4.

Engaging selector lever positions

- ▷ The selector lever can be moved out of position P only with the engine running: interlock.
- ▷ Before moving the lever away from P or N with the vehicle stationary, first depress the brake; otherwise, the desired shift will not be executed: shiftlock.

Shifting into N, D, R



Briefly push the selector lever in the desired direction, overcoming a resistance point if necessary. When shifting out of P or into R, simultaneously press the button **1**.

The engaged selector lever position is also displayed on the selector lever.

When you release the selector lever, it returns to its center position.

Shifting into P

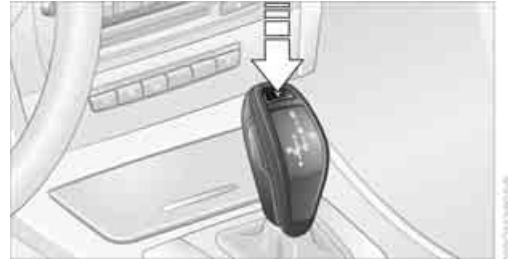

Press the button **P**.

P Park

Select this only when the vehicle is stationary. The rear wheels are locked.

▶ The transmission is shifted into P if, with the engine running, you open the driver's door, do not have your safety belt fastened, and subsequently actuate neither the brake pedal nor the accelerator. Before leaving the vehicle, make sure that the automatic transmission selector lever is in the park position. Otherwise, the vehicle may begin to move. ◀

▶ The transmission is shifted into P as soon as you switch off the engine, unless the transmission is in N and the remote control is in the ignition lock, refer to page 205. As soon as you remove the remote control from the ignition lock, then the transmission is shifted into P. ◀

R Reverse

Select this only when the vehicle is stationary.

N Neutral

You can select this in a car wash, for example. The vehicle can roll.

▶ After the engine is switched off, the transmission remains in N if you leave the remote control in the ignition lock. You can use this function at a car wash, for example, refer to page 205. ◀

D Drive mode

In Drive mode, all forward gears are shifted automatically.

Kickdown

For sudden acceleration maneuvers such as passing, depress the accelerator past the resistance point. This provides maximum acceleration.

Sport program and manual mode M/S



Push selector lever toward the left from the selector lever position D, the Sport program is activated. This position is recommended for a performance-oriented driving style. The engaged gear, e.g. S1, is displayed in the instrument cluster.

When you press the selector lever forwards or backwards, the manual mode is activated and Steptronic changes gear.

The engaged gear, e.g. M1 is displayed in the instrument cluster.

In the following situations, the 7-gear Sport automatic transmission with double clutch does the thinking for you:

- ▷ Upshifts and downshifts are executed only when they will result in a plausible combination of engine and vehicle speed; thus, for example, a downshift that could cause the engine to overrev will not be executed by the system.

- ▷ At a stop, the transmission is automatically shifted down to the first gear.
- ▷ Shortly before the speed falls below a gear-dependent minimum speed, the transmission automatically downshifts without your intervention.

Quick downshifting: even in sequential mode, you can skip over several gears in order to achieve an optimum acceleration. To do so, depress the accelerator past the resistance point.

To return to automatic mode, push the selector lever to the right.

Gear shifting

Upshift or downshift using the selector lever or the shift paddles. You do not need to lift your foot off the accelerator when doing so.

Using the selector lever

- ▷ To upshift, pull the selector lever toward the rear.
- ▷ To downshift, push it toward the front.

Using the shift paddles on the steering wheel

You can also shift manually using two shift paddles on the steering wheel. The shift paddles allow you to shift gears quickly since both hands can remain on the steering wheel.

- ▷ When you use the shift paddles on the steering wheel to shift gears in automatic mode, the transmission switches to manual mode.
- ▷ If you do not accelerate or shift gears using the shift paddles for a certain amount of time, the transmission switches back to automatic mode if the selector lever is in position D.



- ▷ To upshift, briefly pull the right shift paddle +.
- ▷ To downshift, briefly pull the left shift paddle -.

Driving dynamics control

The driving dynamics control permits you, at the push of a button, to have your BMW react in an even more sporty fashion when driving:

- ▷ Optimal use is made of the engine's speed range.
- ▷ Gear changes occur more quickly.
- ▷ The engine reacts more spontaneously to accelerator pedal movements.

Activating the system



Press the SPORT button. The LED in the button lights up and SPORT appears in the info display.

Deactivating the system

- ▷ Press the SPORT button again.
- ▷ Switch off the engine.

The LED in the button goes out and SPORT disappears from the info display.

Manually unlocking parking lock

In the event of a power supply interruption such as a discharged or disconnected battery or an electrical malfunction, the parking lock must be manually unlocked; otherwise, the rear wheels are immobilized and the vehicle cannot be towed. ◀

Only unlock the parking lock manually for towing and make sure to set the parking brake forcefully beforehand so that the vehicle cannot roll. Lock the parking lock again after the vehicle is parked.

Releasing

1. Unclip the sleeve of the selector lever.
2. Pull the sleeve up over the selector lever until the sleeve is inside out.



3. Using the allen wrench from the tool kit, refer to page 208, rotate the cover until it reaches the stop, arrow 1, and remove, arrow 2.



4. Insert allen wrench into the opening, arrow 1.

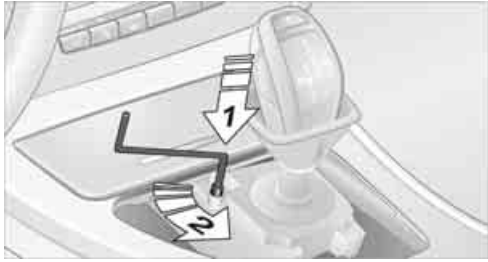

5. Rotate allen wrench until it reaches the stop, arrow 2. The parking lock is unlocked.

 Do not turn allen wrench in the opposite direction; otherwise, you may damage the mechanism. ◀

6. Remove allen wrench from the opening.

 After parking the vehicle, lock the parking lock again. Otherwise, there is a danger that the vehicle will roll. ◀

Locking

1. Press the button, see arrow.
The parking lock is locked again.



2. Replace cover again.
3. Clip the selector lever sleeve back into place.
4. Forcefully apply the parking brake.

Jump-starting and towing, starting on page 217.

Launch Control

Launch Control enables an optimum acceleration when starting off on a road surface with good traction.

 Do not use Launch Control too often; otherwise, the powerful stresses on the vehicle will lead to premature component wear. ◀

Launch Control is available when the engine is at operating temperature, i.e. after driving continuously for approx. 6.2 miles/10 km.

1. With the engine running, step on the brake with your left foot.
2. Activate Dynamic Traction Control (DTC), refer to page 91.
3. Activate Driving dynamics control, refer to page 65.
4. With the vehicle stationary, activate the manual mode and select 1st gear.
5. With your right foot, push the accelerator pedal past the resistance point. The engine speed for pulling away is adjusted. A flag symbol appears in the instrument cluster.
6. When you release the brake pedal, the vehicle accelerates. Keep the accelerator pedal floored.
7. The upshifting occurs automatically as long as you keep the accelerator pedal pressed past the resistance point.

Launch Control will be ready for use again after you drive a certain distance.

Launch Control is not available for use during the break-in phase, refer to page 132.

 To maintain driving stability, keep DSC activated whenever possible. ◀

Turn signals/ headlamp flasher

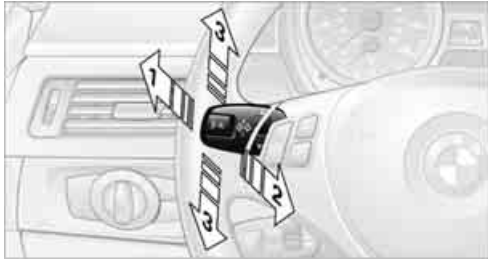

- 1 High beams
- 2 Headlamp flasher
- 3 Turn signal

Using turn signals

Press the lever beyond the resistance point.

To turn off manually, press the lever to the resistance point.

 Unusually rapid flashing of the indicator lamp indicates that a turn signal indicator has failed. ◀

Signaling a turn briefly

Press the lever as far as the resistance point for as long as you wish to signal a turn.

Triple turn signal activation

Press the lever as far as the resistance point. The turn signals flash three times.

You can activate or deactivate this function.

1. Switch on the ignition, refer to page 57.
2. Briefly press button 1 in the turn signal/high beam lever up or down repeatedly until the

symbol appears in the display, accompanied by the word "SET".



3. Press button 2.
4. Briefly press button 1 in the turn indicator lever down repeatedly until the symbol appears in the display.



5. Press button 2.
6. Use button 1 to select:
 - ▷ 1 x
Turn signals flash once.
 - ▷ 3 x
Triple turn signal.
7. Press button 2.
The setting is stored for the remote control currently in use.

Wiper system

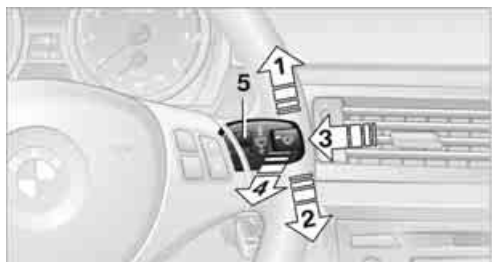

- 1 Switching on wipers
- 2 Switching off wipers or brief wipe
- 3 Activating/deactivating intermittent wipe or rain sensor
- 4 Cleaning windshield and headlamps
- 5 Setting speed for intermittent wipe or sensitivity of the rain sensor

Switching on wipers

Press the lever upward, arrow 1.

The lever automatically returns to its initial position when released.

Normal wiper speed

Press once.

The system switches to operation in the intermittent mode when the vehicle is stationary.

Fast wiper speed

Press twice or press beyond the resistance point.

The system switches to normal speed when the vehicle is stationary.

Intermittent wipe or rain sensor

If the car is not equipped with a rain sensor, the intermittent-wipe time is a preset.

If the car is equipped with a rain sensor, the time between wipes is controlled automatically and depends on the intensity of the rainfall. The rain sensor is mounted on the windshield, directly in front of the interior rearview mirror.

Activating intermittent wipe or rain sensor



Press the button, arrow 3. The LED in the button lights up.

Setting speed for intermittent wipe or sensitivity of the rain sensor

Turn thumbwheel 5 up or down.

Deactivating intermittent wipe or rain sensor

Press the button again, arrow 3. The LED goes out.

 Deactivate the rain sensor before entering an automatic car wash. Failure to do so could result in damage caused by undesired wiper activation. ◀

Cleaning windshield and headlamps

Pull the lever, arrow 4.

Washer fluid is sprayed onto the windshield and the wipers are operated for a short time.

When the vehicle lighting system is switched on, the headlamps are cleaned at regular and appropriate intervals.

 Do not use the washers if there is any danger that the fluid will freeze on the windshield. If you do, your vision could be obscured. Antifreeze should therefore be added to the fluid, refer to Washer fluid. Do not use the washers when the washer fluid reservoir is empty; otherwise, you will damage the washer pump. ◀

Windshield washer nozzles

Both windshield washer nozzles are automatically heated with the engine running or the ignition switched on.

Washer fluid

! Washer fluid antifreeze is flammable. Therefore, keep it away from ignition sources and only store it in the closed original container that is kept out of reach of children; otherwise, there is a risk of personal injury. Comply with the instructions on the container. ◀

Washer fluid filler neck

! Only refill washer fluid when the engine is cool to avoid contact with hot engine parts. Otherwise, fluid spills constitute a fire hazard and a risk to personal safety. ◀

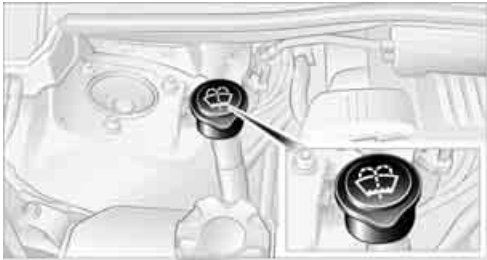

All washer nozzles are supplied with washer fluid by the same reservoir.

Fill with water and, if required, with a washer antifreeze, according to manufacturer's recommendations.

▷ Mix the water and antifreeze before filling the washer fluid reservoir to make sure the correct concentration is maintained. ◀

Capacity

Approx. 6.3 US quarts/6 liters.

Cruise control

The concept

Cruise control is available for use at speeds of approx. 20 mph or 30 km/h. The car then stores and maintains the speed that you specify using the lever on the steering column. In order to maintain the specified speed, the system brakes the vehicle when the engine braking effect is insufficient on downhill gradients.

! Do not use cruise control when driving at constant speed is prevented by adverse conditions, e.g. winding roads, dense traffic or poor road conditions due to, e.g., snow, rain, ice or loose surfaces. Otherwise, you could lose control of the vehicle and cause an accident as a result. ◀

Manual transmission

You can shift gears while cruise control is activated. The system is deactivated when you drive at very low engine speeds for an extended period.

One lever for all functions

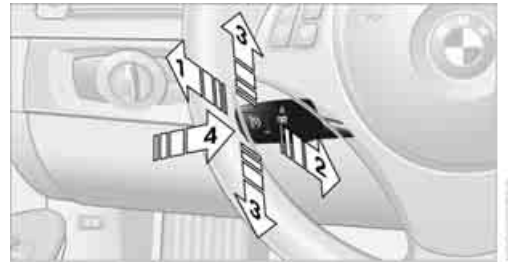

- 1 Storing and maintaining speed or accelerating
- 2 Storing and maintaining speed or decelerating
- 3 Deactivating cruise control
- 4 Resuming a previously stored speed

Maintaining current speed

Briefly press the lever, arrow **1**, or pull it briefly, arrow **2**.

The car's current speed is stored and maintained. It is displayed on the speedometer and briefly in the instrument cluster.

On uphill gradients, it may prove impossible to maintain the set speed if current engine power output is insufficient. If the engine braking effect is insufficient on downhill slopes, the system will brake the vehicle slightly.

Increasing desired speed

Repeatedly press the lever to the resistance point or beyond, arrow **1**, until the desired speed is reached.

- ▷ Each time the lever is pressed to the resistance point, the desired speed is increased by approx. 1 mph or 1 km/h.
- ▷ Each time the lever is pressed beyond the resistance point, the desired speed is increased by up to 5 mph or 10 km/h.

The system stores and maintains the speed.

Accelerating using the lever

Accelerating slightly:

Press the lever to the resistance point, arrow **1**, until the desired speed is reached.

Accelerating significantly:

Press the lever beyond the resistance point, arrow **1**, until the desired speed is reached.

The vehicle accelerates without pressure on the accelerator pedal. The system stores and maintains the speed.

Decreasing speed

Repeatedly pull the lever to the resistance point or beyond, arrow **2**, until the desired speed is displayed.

- ▷ Each time the lever is pulled to the resistance point, the desired speed is decreased by approx. 1 mph or 1 km/h.

- ▷ Each time the lever is pulled beyond the resistance point, the desired speed is reduced by up to 5 mph or 10 km/h until the minimum speed of 20 mph or 30 km/h is achieved.

The system stores and maintains the speed.

Deactivating cruise control

Briefly press the lever upwards or downwards, arrow **3**.

The displays on the speedometer disappear.

In addition, the system is automatically deactivated:

- ▷ When the brakes are applied.
- ▷ When the manual transmission is shifted very slowly or shifted into neutral.
- ▷ When the automatic transmission selector lever is moved into the neutral position.
- ▷ When the selector lever of the Sports automatic transmission with double clutch is moved into the neutral position.
- ▷ When DTC is activated or DSC is deactivated.
- ▷ When DSC or ABS is intervening.

Cruise control is not deactivated by depressing the accelerator pedal. Once the accelerator pedal is released, the stored speed is achieved again and maintained.

Warning lamp



The warning lamp lights up when cruise control is deactivated due to control intervention by the DSC, for example.

Resuming a previously stored speed

Press the button, arrow **4**.

The last stored speed is resumed and maintained.

In the following instances, the stored speed is deleted and can no longer be resumed:

- ▷ When driving stability control systems are intervening.
- ▷ In cars with manual transmission: when you shift gears very slowly or shift to neutral.
- ▷ In cars with automatic transmission: when you engage selector lever position N.
- ▷ In cars with Sport automatic transmission with double clutch: when you engage selector lever position N.
- ▷ When the ignition is switched off.

Displays in the instrument cluster



- 1 Stored speed
- 2 Selected speed is displayed briefly

▷ If --- mph or --- km/h temporarily appears in the instrument cluster display, it is possible that the system prerequisites for operation are currently not met.

Calling up Check Control messages, refer to page 88. ◀

Malfunction



The warning lamp lights up. The cruise control is malfunctioning. You can continue your journey. Have the system checked.

Active Cruise Control

The concept

With Active Cruise Control, you can select a desired speed which is not only automatically maintained when driving on open roadways, but also varied to maintain a selected distance setting as slower traffic is encountered.

Active Cruise Control is a technological advance over the familiar cruise control and is a welcome relief from the constant adjustment of speed that can accompany driving in traffic on highways or other high-speed thoroughfares. Especially on longer trips, the system can reduce fatigue and tension, while increasing your enjoyment of driving. Please use it safely and responsibly.

Within the limits of its capability, the system automatically adapts the car's speed to that of a slower vehicle in front of you. You can specify the distance to be maintained from the vehicle in front in four stages. For safety reasons, the distance is speed-dependent. Based on your selected distance setting, the system automatically decreases the throttle setting and lightly applies the brakes if necessary. The vehicle brake lamps will automatically illuminate to signal a following driver to take action. In addition, it may be necessary for the vehicle or the driver to downshift, depending on the kind of transmission your vehicle is equipped with, to maintain the distance setting selected. If the vehicle ahead speeds up or when the lane ahead becomes clear, your vehicle will accelerate to the speed you have selected by increasing the throttle setting and shifting gears automatically or by the driver as needed. Your selected speed will be held when driving downhill, too.

Since this Active Cruise Control system is a new technology and operates differently from conventional cruise control systems which you may be accustomed to, you are strongly urged to read all of the pages relating to this system before use. Pay special attention to the System limitations section beginning on page 76.

Braking sensation

- ▷ If you step on the brake pedal while the system is braking, pedal sensation will be slightly different from the usual.
- ▷ Possible noises during automatic braking are normal.

Manual transmission

You can shift gears while cruise control is activated. The system is deactivated when you drive at very low engine speeds for an extended period.

Range of applications

The minimum desired speed is 20 mph or 30 km/h, the maximum desired speed is 110 mph or 180 km/h.

 As with conventional cruise control systems, Active Cruise Control in no way diminishes or substitutes for the driver's own personal responsibility, alertness and awareness in adjusting speed, braking or otherwise controlling the vehicle. The driver should decide when to use the system on the basis of road, traffic, visibility, and weather conditions. Active Cruise Control is intended for use on highway-type roadways where traffic is moving relatively smoothly. Do not use this system in city driving; heavy traffic such as during rush hour; on curvy, winding roads, slippery roads or roads with sharp curves such as highway off-ramps; during inclement weather such as snow, strong rain or fog; or when entering interchanges, service/parking areas or toll booths. It is also important to regulate your vehicle's speed and distance setting within applicable legal limits. Always be ready to take action or apply the brakes if necessary, especially when the system is actively following a vehicle in front of you. Otherwise, driving situations could result that pose the risk of accidents. ◀

One lever for all functions

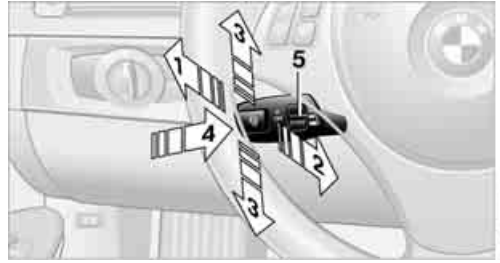

- 1 Store and increase desired speed
- 2 Store and decrease desired speed
- 3 Deactivate system, refer to page 73
- 4 Resume stored desired speed and distance, refer to page 74
- 5 Select distance to vehicle driving ahead, refer to page 73

Storing current speed

Briefly press the lever, arrow 1, or pull the lever, arrow 2, at a driving speed of more than approx. 20 mph or 30 km/h.



The car's current speed is stored. It is displayed on the speedometer and briefly in the instrument cluster.

Increasing desired speed

Press or briefly press the lever to the resistance point or beyond, arrow 1, until the desired speed is displayed.

- ▷ Each time the lever is briefly pressed to the resistance point, the desired speed is increased by approx. 1 mph or 1 km/h.
- ▷ Each time the lever is briefly pressed beyond the resistance point, the desired speed is increased by up to 5 mph or 10 km/h until the maximum speed of 110 mph or 180 km/h is achieved.

The speed then displayed is stored and achieved on a clear road.

Decreasing desired speed

Pull the lever, arrow 2, until the desired speed is displayed.

The other functions work analogously to those described under Increasing desired speed.

Selecting distance

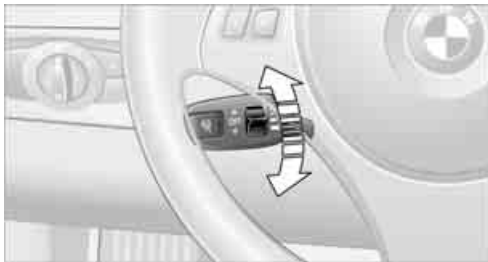

- ▷ Press downward: Increase distance.
- ▷ Press upward: Decrease distance.

The selected distance is displayed in the instrument cluster.



Distance 1

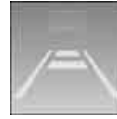

Distance 2

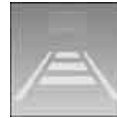

Distance 3



Distance 4

This is always the preset distance when you use the system for the first time after starting the engine.

 Use good judgment to select the appropriate following distance given road conditions, traffic, applicable laws and driving recommendations for safe following distance. Otherwise, an accident risk could result. ◀

Deactivating cruise control

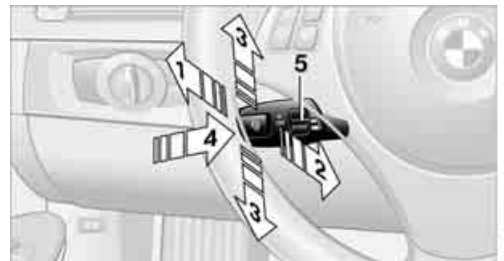

Press the lever upward or downward, arrow 3. The displays on the speedometer disappear. In addition, the system is automatically deactivated:

- ▷ When the brakes are applied.
- ▷ The speed is reduced to below 20 mph or 30 km/h due to a traffic situation.
- ▷ When the manual transmission is shifted very slowly or shifted into neutral.
- ▷ When the automatic transmission selector lever is moved into the neutral position.
- ▷ When the selector lever of the Sports automatic transmission with double clutch is moved into the neutral position.
- ▷ When Dynamic Traction Control DTC is activated.
- ▷ When Dynamic Stability Control DSC is deactivated.
- ▷ When DSC or ABS is intervening.
- ▷ The system does not recognize any objects for a longer time, e.g. on infrequently traveled roads without a shoulder or guard rails, or if the radar sensor is covered with dirt, refer to page 75.
- ▷ The parking brake is engaged.

 When the system is deactivated, you must brake the vehicle yourself and/or maneuver as necessary; otherwise, there is a risk of accidents. ◀

Warning lamp



The warning lamp lights up when Active Cruise Control has been automatically deactivated, for example due to a driving speed below 20 mph or 30 km/h or a DSC intervention.

Resuming stored desired speed and distance

Briefly press the button, arrow 4.

The stored speed and distance are regained and maintained.

In the following instances, the stored speed is deleted and can no longer be resumed:

- ▷ When driving stability control systems are intervening.
- ▷ In cars with manual transmission: when you shift gears very slowly or shift to neutral.
- ▷ In cars with automatic transmission: when you engage selector lever position N.
- ▷ In cars with Sport automatic transmission with double clutch: when you engage selector lever position N.
- ▷ When the ignition is switched off.

Displays in the instrument cluster



- 1 Stored desired speed
- 2 Shows yellow: vehicle detected ahead
Flashes in red: system cannot maintain distance; driver must brake the vehicle
Flashes in yellow: driving stability control systems are intervening; cruise control is deactivated
- 3 Selected distance to vehicle ahead
The indicator lights up as soon as the system is activated.
- 4 Selected desired speed is temporarily displayed

 If --- mph or --- km/h temporarily appears in the instrument cluster display, it is possible that the system prerequisites for operation are currently not met. Calling up Check Control messages, refer to page 88. ◀

Warning lamps



The indicator **2** flashes in red; a signal sounds.

The system indicates that you must brake and/or maneuver the vehicle yourself. Active Cruise

Control cannot automatically restore the distance to the vehicle ahead.

This indicator does not release you from your responsibility to adapt your desired speed and driving style to prevailing driving conditions.



The indicator **2** flashes in yellow. The prerequisites for operating Active Cruise Control are not met, e.g. as a result of ABS or DSC interventions. Active Cruise Control

is deactivated. You can reactivate the system, if desired, by briefly pressing or pulling the lever when road and traffic conditions permit. It is not possible to resume a stored speed.

Radar sensor



The sensor's ability to detect vehicles ahead may be restricted as a result of heavy rain, dirt, snow or ice. If necessary, clean the radar sensor located in the front bumper, see arrow. Be sure to use particular care when removing any layers of snow or ice from the sensor.

The system cannot be activated if the sensor is incorrectly aligned.

For US owners only

The transmitter and receiver units comply with part 15 of the FCC/Federal Communications Commission regulations. Operation is governed by the following:

FCC ID:

NF3 ACC2SCU 003YK04001 0000

Compliance statement:

This device complies with part 15 of the FCC Rules. Operation is subject to the following two conditions:

- ▷ This device must not cause harmful interference, and
- ▷ this device must accept any interference received, including interference that may cause undesired operation.



Any unauthorized modifications or changes to these devices could void the user's authority to operate this equipment. ◀

Malfunction



The warning lamp lights up. The Active Cruise Control is malfunctioning. Have the system checked.

System limitations

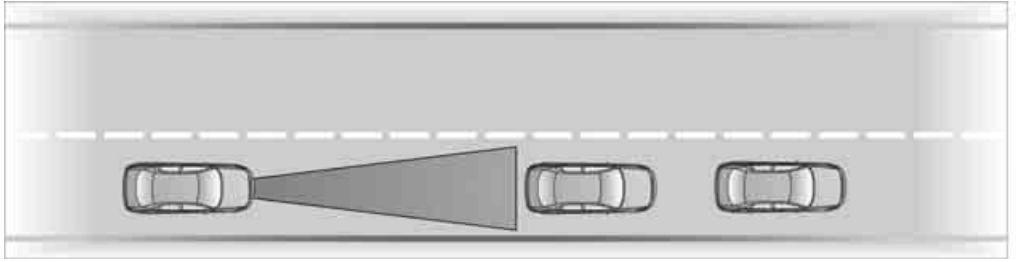

⚠ Always remember that the range and ability of the system does have physical limitations. It will not apply the brakes or decelerate your vehicle when there is a slow-moving vehicle, stopped vehicle, or stationary object ahead of you, for example at a traffic light or when approaching a parked vehicle. Also, the system does not react to oncoming traffic, pedestrians or other types of potential traffic such as a rider on horseback. The system may also not detect smaller moving objects such as motorcycles or bicycles. Be especially alert when encountering any of these situations as the system will neither automatically brake, nor provide a warning to you. Also, be aware that every decrease in the distance setting allows your vehicle to come closer to a vehicle in front of you and requires a heightened amount of alertness. ◀

⚠ Active Cruise Control is not and must not be used as a collision avoidance/warning system. ◀

If while your vehicle is actively following a vehicle in front of you and the vehicle ahead speeds up or the lane ahead becomes clear, then your vehicle will accelerate to the speed you have selected. Be aware that changing to a clear, unobstructed lane will also result in your vehicle accelerating.

⚠ Be certain to deactivate the system when you pull into an exit lane for a highway off-ramp. ◀

Also, vehicles traveling in a staggered manner on a highway may cause a delay in the system's reaction to a vehicle in front of you or may cause the system to react to a vehicle actually in the lane next to you. Always be ready to take action or apply the brakes if necessary.

⚠ While Active Cruise Control is capable of braking your vehicle automatically when you approach a slower vehicle ahead, it is important to be aware that the ability of the system to apply the brakes is also limited, e.g. when you reduce your desired speed sharply. The system cannot stop your vehicle. It uses only a portion of braking system capacity and does not utilize the full capacity of the vehicle braking system. Therefore, the system cannot decrease your speed for large differences in speed between your vehicle and the vehicle ahead. Examples: when you approach a vehicle traveling at a much lower speed than your own speed such as approaching a toll booth or when a much slower vehicle cuts in front of you at close range. ◀

Active Cruise Control can only decelerate the vehicle to approx. 20 mph or 30 km/h.

Swerving vehicles

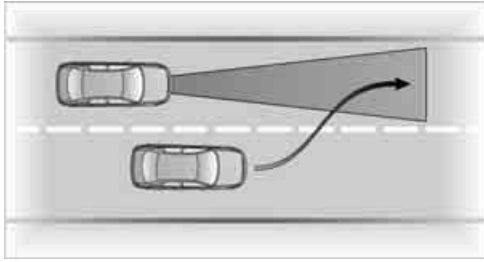

When a vehicle moves from an adjacent lane into your lane, Active Cruise Control will not recognize this vehicle until it is fully in your lane ahead of your vehicle.

⚠ When a vehicle ahead suddenly swerves into your lane, the system may not be able to maintain the selected distance automatically. This also applies to great differences in speed between you and vehicles ahead, e.g. when quickly approaching a truck. There is a risk of collision. Once the system has established that a vehicle is indeed in front of you, it will indicate that you must brake and/or maneuver the vehicle yourself. Take action yourself; otherwise, there is a risk of an accident. ◀

Behavior in curves

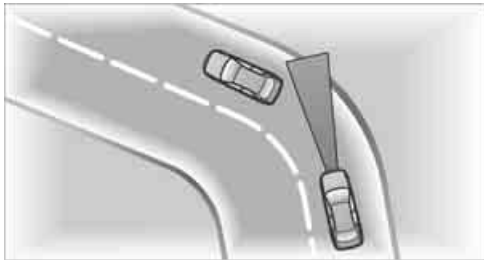

Because of the limited range of the system, it is possible that in curves or on the peaks and valleys of hilly roads, a vehicle ahead may be recognized late, or not at all. Therefore, it is up to the driver to select a speed that is prudent in view of the curves and terrain of the roadway.



In approaching a curve, it is possible that Active Cruise Control would react briefly to a vehicle in the adjacent lane. In addition, the system can sense if your vehicle is in a curve and may not accelerate. If your vehicle decelerates in either case, you can choose to overcome the deceleration by briefly pressing the accelerator pedal.

Your responsibility

Your actions have priority at all times. When you press the accelerator pedal while driving with Active Cruise Control, the automatic braking function will be temporarily interrupted. Once you release the accelerator pedal, the desired speed or the selected distance to the vehicle ahead is achieved again.

⚠ Do not leave your foot on the accelerator pedal and make sure that no objects such as floor mats are lying on the accelerator pedal. Otherwise, the system may not be able to brake the vehicle. ◀

Controls overview

Vehicle equipment

In this chapter, all production, country, and optional equipment that is offered in the model range is described. For this reason, descriptions will be given of some equipment that may not be available in a vehicle, for example due to the special options or national-market version selected. This also applies to safety related functions and systems.

Odometer, outside temperature display, clock



- 1 Knob in the instrument cluster
- 2 Outside temperature display and clock
- 3 Odometer and trip odometer

Knob in the instrument cluster

- ▷ To reset the trip odometer while the ignition is switched on
- ▷ To display the time, outside temperature and odometer briefly while the ignition is switched off

Units of measure

To select the respective units of measure, miles or km for the odometer as well as °F or °C for the outside temperature, refer to page 83.

The setting is stored for the remote control currently in use.

Time, outside temperature display

Setting the time, refer to page 86.

Outside temperature warning

When the displayed temperature sinks to approx. +37 °F / +3 °C, a signal sounds and a warning lamp lights up. There is an increased risk of black ice.

 Black ice can also form at temperatures above +37 °F / +3 °C. You should therefore drive carefully on bridges and shaded roads, for example; otherwise, there is an increased risk of an accident. ◀

Odometer and trip odometer

Resetting the trip odometer:

With the ignition switched on, press button 1 in the instrument cluster.

When the vehicle is parked

If you still want to view the time, outside temperature and odometer reading briefly after the ignition lock: Press button 1 in the instrument cluster.

Tachometer



Never force the engine speed up into the red warning field, see arrow. In this range, the fuel supply is interrupted to protect the engine.

Engine oil temperature



When the engine is at normal operating temperature, the engine oil temperature is between approx. 210 °F / 100 °C and approx. 300 °F / 150 °C.

If the engine oil temperature is too high, a warning lamp lights up in the instrument cluster.

Fuel gauge



Fuel tank capacity: approx. 16.1 US gal/ 61 liters.

You can find information on refueling on page 175.

If the tilt of the vehicle varies for a longer period, when you are driving in mountainous areas, for example, the indicator may fluctuate slightly.

Reserve

Once the fuel level has fallen to the reserve zone of approx. 2.1 US gal/8 liters, the indicator lamp and the cruising range for the remaining amount of fuel light up briefly. The indicator lamp remains permanently on when the remaining range is less than approx. 30 miles/50 km.

With a dynamic driving style, e.g. rapid cornering, engine functions are not always assured.

 Refuel as soon as possible once your cruising range falls below 30 miles/ 50 km; otherwise, engine functions are not ensured and damage can occur. ◀

Computer

Displays in the instrument cluster

Calling up information



Press the button in the turn signal/high beam lever.

The following items of information are displayed in the order listed:

- ▷ Cruising range
- ▷ Average speed
- ▷ Average fuel consumption
- ▷ Current fuel consumption
- ▷ No information

To set the corresponding units of measure, refer to Formats and units of measure on page 83.

Cruising range

Displays the estimated cruising range available with the remaining fuel. The range is calculated on the basis of the way the car has been driven over the last 18 miles/30 km and the amount of fuel currently in the tank.

 Refuel as soon as possible once your cruising range falls below 30 miles/50 km; otherwise, engine functions are not ensured and damage can occur. ◀

Average speed

Periods with the vehicle parked and the engine switched off are not included in the calculations of average speed.

To reset average speed: press the button in the turn signal/high beam lever for approx. 2 seconds.

Average fuel consumption

The average fuel consumption is calculated for the time during which the engine is running.



To reset average fuel consumption: press the button in the turn signal/high beam lever for approx. 2 seconds.

Current fuel consumption

Displays the current fuel consumption. This allows you to see whether your current driving style is conducive to fuel economy with minimum exhaust emissions.

Displays in BMW Professional radio

Calling up information

1. Switch on radio readiness or ignition.
2.  Press the button.
3.  Press the button.

Fuel consumption

Displays the average fuel consumption, e.g. for the whole trip, a leg of the trip, or after each refueling. The average fuel consumption is calculated for the time during which the engine is running.

To start the of the consumption calculation:



1.  Press the button.
2.  Press the button.

The previous display is set to zero and the system begins to recalculate the average fuel consumption.

Average speed

An average speed driven can be displayed. The average speed is calculated for the time during which the engine has been running.

To start the calculation of the average speed:

1.  Press the button.
2.  Press the button.

The previous display is set to zero and the system begins to recalculate the average speed.

Cruising range

"RANGE"

The display shows the estimated distance that can still be driven with the existing fuel quantity, taking into account the prior average fuel consumption.

Settings and information

Operating principle



Certain settings and information can only be called up when the ignition is switched on. A number of settings cannot be made while driving.

- 1 Button for:
 - ▷ Selecting display
 - ▷ Setting values
- 2 Button for:
 - ▷ Confirming selected display or set values
 - ▷ Calling up computer information 80
- 3 When the lights are on: instrument lighting brightness 107
- 4 Calling up Check Control 87
- 5 Checking oil level 198
- 6 Initializing the Flat Tire Monitor 93
Resetting the Tire Pressure Monitor 95
- 7 Setting the time 86
- 8 Setting the date 86
- 9 Viewing service requirement display 84

10 Setting formats and units of measure, resetting to factory settings 83

11 Adjusting settings

- ▷ Confirmation signals when locking and unlocking the vehicle 27
- ▷ Response during unlocking procedure 25
- ▷ Automatic locking 29
- ▷ Pathway lighting 104
- ▷ Daytime running lights 104
- ▷ Triple turn signal activation 67
- ▷ Seat memory 49

Exiting displays

The outside temperature reading and the time reappear when you press button 2 or if you make no entries within approx. 15 seconds. If required, complete the current setting first.

Formats and units of measure

In the instrument cluster

Setting the units of measure

You can set formats and units of measure.

1. Switch on the ignition, refer to page 57.
2. Briefly press button **1** in the turn signal/high beam lever up or down repeatedly until the symbol appears in the display, accompanied by the word "SET".



3. Press button **2**.
4. Use button **1** to select desired format or desired unit of measure, e.g. for fuel consumption.



- ▷ Fuel consumption: mpg, km/l, l/100km
 - ▷ Distance covered: mls, km
 - ▷ Time: 12h, 24h format
 - ▷ Date: day.month dd.mm, month/day mm/dd
 - ▷ Temperature: °F, °C
5. Press button **2**.
 6. Use button **1** to make the setting.

7. Press button **2**.
The setting is stored for the remote control currently in use.

Resetting to factory settings

You can reset the settings for formats and units of measure to the factory settings.

1. Briefly press button **1** in the turn signal/high beam lever up or down repeatedly until the symbol appears in the display, accompanied by the word "SET".



2. Press button **2**.
3. Use button **1** to select "RESET".



4. Press button **2** until is displayed.
The settings are reset.
The setting is stored for the remote control currently in use.

In BMW Professional radio

Adjusting

1. Switch on radio readiness or ignition.
2. Press the button.

3.  Press the button.
 - ▷ "DIST": change the unit of measurement for the range.
 - ▷ "LANG": select the language of the display text.
 - ▷ "CONSP": change the unit of measurement for the average fuel consumption.
 - ▷ "TEMP": change the unit of measurement for the external temperature.
4. Highlight the desired menu item and press the button.
5. Make the desired setting.

The settings of the units of measurement are adopted for the displays in the radio and in the instrument cluster and are stored in the remote control currently in use.



1. Switch on the ignition, refer to page 57.
2. Push button 1 in the turn signal/high beam lever up or down repeatedly until the appropriate symbol appears in the display, accompanied by the words "SERVICE-INFO".
3. Press button 2.
4. Use button 1 to scroll through the individual service items.

Service requirements



The remaining driving distance and the date of the next scheduled service are displayed briefly immediately after you start the engine or switch on the ignition.

- ▷ The extent of service work required can be read out from the remote control by your dealership Service Advisor. ◀

For certain maintenance operations, you can view the respective distance remaining or due date individually in the instrument cluster.

Possible displays



- 1 Button for selecting functions
- 2 Service requirements
- 3 Engine oil
- 4 Roadworthiness test

- 5 Front brake pads
- 6 Rear brake pads
- 7 Brake fluid

The sequence of displayed service items may vary. The data for the next service appointment is shown first.

Clock



Setting the time

To set the 12h/24h mode, refer to Formats and units of measure on page 83.



1. Push button **1** in the turn signal/high beam lever up or down repeatedly until the appropriate symbol appears in the display, accompanied by the time and the word "SET".
2. Press button **2**.
3. Use button **1** to set the hours.
4. Press button **2** to confirm the entry.
5. Use button **1** to set the minutes.
6. Press button **2** to confirm the entry.
7. Press button **2**.
The system accepts the new time.

In BMW Professional radio

1. Switch on radio readiness or ignition.
2.  Press the button.
3.  Press the button.
4.  Press the button.
5. Select the desired category.
6. Adjust the settings and press the knob on the right.

Date



Setting the date

To set the dd/mm or mm/dd date format, refer to Formats and units of measure on page 83.



1. Push button **1** in the turn signal/high beam lever up or down repeatedly until the appropriate symbol appears in the display, accompanied by the date and the word "SET".
2. Press button **2**.
3. Use button **1** to set the day of the month.
4. Press button **2** to confirm the entry.
5. Set the month and the year in the same way.
6. Press button **2**.
The system stores the new date.

In BMW Professional radio

1. Switch on radio readiness or ignition.
2.  Press the button.
3.  Press the button.
4.  Press the button.
5. Select the desired category.
6. Adjust the settings and press the knob on the right.

Check Control

The concept

The Check Control monitors vehicle functions and alerts you to any malfunctions in the systems monitored. This type of Check Control message includes indicator and warning lamps in the instrument cluster and, in some cases, an acoustic signal.



Indicator and warning lamps can light up in a variety of combinations and colors.

Several of the lamps are checked for proper functioning and light up temporarily when the engine is started or the ignition is switched on.



⚠ Indicates that Check Control messages have been stored. These Check Control messages can be viewed again later, refer to page 88.

What to do in case of a malfunction

The meaning of each lamp in the event of a malfunction and tips on how to respond are listed starting on page 220.

Hiding Check Control messages

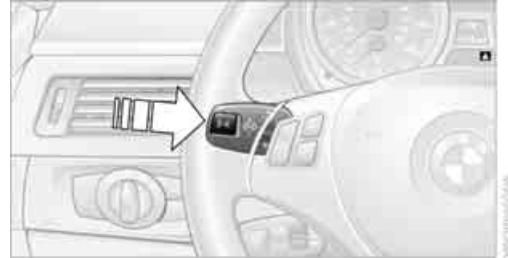

Press the button on the turn signal/high beam lever.

- ▷ Some Check Control messages are displayed continuously and remain visible until the malfunction has been rectified. If several malfunctions occur at once, the messages are displayed consecutively. These messages can be hidden for approx. 8 seconds. After this, they are displayed again automatically.
- ▷ Other Check Control messages are hidden automatically after approx. 20 seconds. They are stored and can be displayed again later.

Displaying stored Check Control messages



1. Push button **1** in the turn signal/high beam lever up or down repeatedly until the appropriate symbol appears in the display, accompanied by the words "CHECK CONTROL".
2. Press button **2**.
If there are no Check Control messages, then "CHECK OK" is displayed.
If a Check Control message has been stored, the corresponding lamp lights up.
3. Push button **1** to check for other messages.
4. Press button **2**.
The display again shows the outside temperature and the time.

Technology for driving comfort and safety

Vehicle equipment

In this chapter, all production, country, and optional equipment that is offered in the model range is described. For this reason, descriptions will be given of some equipment that may not be available in a vehicle, for example due to the special options or national-market version selected. This also applies to safety related functions and systems.

Park Distance Control PDC

The concept

The PDC assists you with maneuvering in tight parking spaces. Acoustic signals warn you of the presence of an object in front of or behind your vehicle. To measure the distance, there are four ultrasonic sensors in either bumper.

An acoustic warning sounds when an object is less than approx. 24 in/60 cm from the front sensors and rear corner sensors or less than approx. 5 ft/1.50 m from the rear center sensors.

 PDC is a parking aid that can indicate objects when they are approached slowly, as is usually the case when parking. Avoid approaching an object at high speed; otherwise, physical circumstances may lead to the system warning being issued too late. ◀

Switching on automatically

With the engine running or the ignition switched on, the system is activated after approx. one second when you shift into reverse or move the automatic transmission selector lever to position R. Wait this short period before driving.

Switching off automatically

After approx. 55 yd/50 m of driving or above approx. 20 mph/approx. 30 km/h, the system switches off and the LED goes out.

Switching on manually

When parking in the forward direction, the sensors must be switched on manually to enable them to signal an approach to an object in front of or behind the vehicle.



Press the button; the LED lights up.

Switching off manually

Press the button again; the LED goes out.

Signal tones

When nearing an object, its position is indicated correspondingly by an interval tone. For example, if an object is detected behind the vehicle, the signal tone sounds from the rear. As the distance between vehicle and object decreases, the intervals between the tones become shorter. If the distance to the nearest object falls to below roughly 1 ft/30 cm, then a continuous tone sounds.

An interval tone is interrupted after approx. 3 seconds

- ▷ If you remain in front of an object that has been detected by only one of the corner sensors
- ▷ If you are driving parallel to a wall.

Malfunction



The warning lamp lights up. PDC is malfunctioning. Have the system checked.

To avoid this problem, keep the sensors clean and free of ice or snow in order to ensure that they will continue to operate effectively. When using a high-pressure cleaner, do not spray the sensors for extended periods of time and only from a distance of at least 1 ft/30 cm.

Manual operation

The LED above the button also flashes.

System limitations



Even with PDC, final responsibility for estimating the distance between the vehicle and any obstructions always remains with the driver. Even when sensors are provided, there is a blind spot in which objects can no longer be detected. The system is also subject to the physical limits that apply to all forms of ultrasonic measurement, such as those encountered with trailer towbars and hitches, thin or wedge-shaped objects, etc. Low objects that have already been displayed, e.g. curbs, can disappear again from the detection area of the sensors before or after a continuous tone sounds. Higher, protruding objects, e.g. ledges, cannot be detected. Therefore, always drive cautiously; otherwise, there is a risk of personal injury or property damage.

Loud sound sources outside or inside the car can drown out the PDC signal. Therefore, always drive cautiously; otherwise, there is a risk of personal injury or property damage. ◀

Driving stability control systems

Your BMW has a number of systems that help to maintain the vehicle's stability even in adverse driving conditions.

ABS Antilock Brake System

ABS prevents locking of the wheels during braking. Safe steering response is maintained even during full braking. Active safety is thus increased.

The ABS is operational every time you start the engine. Braking safely, refer to page 134.

Electronic brake-force distribution EBV

The system controls the brake pressure in the rear wheels to ensure stable braking behavior.

Dynamic Brake Control DBC

When you apply the brakes rapidly, this system automatically produces the maximum braking force boost and thus helps to achieve the shortest possible braking distance during full braking. This system exploits all of the benefits provided by ABS.

Do not reduce the pressure on the brake for the duration of the full braking application.

Dynamic Stability Control DSC

DSC prevents the driving wheels from losing traction when you pull away from rest or accelerate. The system also recognizes unstable driving conditions, for example if the rear of the car is about to swerve or if momentum is acting at an angle past the front wheels. In these cases, DSC helps the vehicle maintain a safe course within physical limits by reducing engine output and through braking actions at the individual wheels.



The laws of physics cannot be repealed, even with DSC. An appropriate driving style always remains the responsibility of the driver. Therefore, do not reduce the additional safety margin again by taking risks, as this could result in an accident. ◀

Deactivating DSC



Press the button for at least 3 seconds until the indicator lamp for DSC OFF lights up and DSC OFF is displayed in the instrument cluster. Dynamic Traction Control DTC and DSC have been simultaneously deactivated. Stabilizing and drive-output promoting actions are no longer executed.

In the same way as with a differential interlock, even if DSC is deactivated, brake actions are still performed to enhance drive output if the drive wheels experience a significant loss of traction.

To increase vehicle stability, activate DSC again as soon as possible.

Activating DSC

Press the button again; the indicator lamp in the instrument cluster goes out.

For better control



If the indicator lamp flashes: the DSC controls the driving and braking forces.

If the indicator lamp lights up: DSC and DTC have failed.



The indicator lamp lights up and DSC OFF is displayed in the instrument cluster: DSC is deactivated.

Dynamic Traction Control DTC

DTC is a version of DSC in which the drive output is optimized for particular road conditions, e.g. unplowed snow-covered roads. The system assures the maximal drive output, but with reduced driving stability. It is therefore necessary to drive with appropriate caution.

You may find it useful to briefly activate DTC under the following special circumstances:

- ▷ When driving uphill on snow-covered roads, in slush or on unplowed, snow-covered roads
- ▷ When rocking a stuck vehicle free or starting off in deep snow or on loose ground
- ▷ When driving with snow chains

Activating DTC



Press the button; the indicator lamp for DSC OFF lights up and TRACTION is displayed in the instrument cluster.

For better control



If the indicator lamp flashes: DTC controls the driving and braking forces.

If the indicator lamp lights up: DSC and DTC have failed.



The indicator lamp lights up and TRACTION is displayed in the instrument cluster: DTC is activated.

Deactivating DTC

Press the button again; the indicator lamp in the instrument cluster goes out.

xDrive

xDrive is your BMW's four-wheel-drive system. The combined efforts of xDrive and DSC help to further optimize traction and driving dynamics. The xDrive four-wheel-drive system distributes driving power variably to the front and rear axles depending on the driving situation and road conditions.

Hill Descent Control HDC

HDC is a downhill driving assistant that controls your speed on steep downhill gradients and makes it even easier to control your BMW's handling under these conditions. The vehicle then moves slightly faster than double walking speed without the driver needing to intervene.

HDC can be activated as long as you are driving under approx. 20 mph or 35 km/h. When driving downhill at a speed of under approx. 20 mph or 35 km/h, the vehicle's speed is automatically reduced to slightly more than double walking speed and maintained.

Increasing or decreasing speed

By accelerating or braking you can change this speed within a range from approx. 3 to 15 mph, approx. 5 to 25 km/h.

You can specify a target speed within the same range by using the lever of the cruise control.



- 1 To increase speed
- 2 To decrease speed

Activating HDC



Press the button; the LED lights up. When the vehicle is being braked automatically, the LED flashes.

Deactivating HDC

Press the button again; the LED goes out.

HDC is automatically deactivated at speeds greater than approx. 35 mph/60 km/h.

Using HDC

In cars with manual transmission:

Use HDC in lower gears and in reverse gear.

With automatic transmission:

You can use HDC in any drive position.

Displays in the instrument cluster



- 1 Display for target speed
- 2 HDC display

Malfunction

The HDC display disappears during HDC operation, or does not appear:

HDC is temporarily unavailable due to excessive brake temperature, or DSC has failed.

Drive-off assistant

The drive-off assistant enables you to drive off smoothly on uphill gradients. It is not necessary to use the parking brake for this.

1. Hold the car in place by depressing the brake.
2. Release the brake and drive off without delay.

 The drive-off assistant holds the car in place for approx. 2 seconds after the brake is released. Drive off without delay after releasing the brake. Otherwise, the drive-off assistant will no longer hold the car in place after approx. 2 seconds and the car will start to roll backwards. ◀

Flat Tire Monitor FTM

The concept

The system does not measure the actual inflation pressure in the tires.

The system detects a pressure loss in a tire by comparing the rotational speeds of the individual wheels while moving.

In the event of a pressure loss, the diameter and therefore the rotational speed of the corresponding wheel change. This is detected and reported as a flat tire.

Functional requirement

The system must have been initialized while the tire inflation pressure was correct; otherwise, reliable signaling of a flat tire is not ensured.

Each time a tire inflation pressure has been corrected or a wheel or tire has been changed, reinitialize the system.

System limitations

 Sudden serious tire damage caused by external influences cannot be indicated in advance. ◀

A natural, steady pressure loss in all four tires is not detected. Therefore, check the tire inflation pressure regularly.

In the following situations, the system could be delayed or malfunction:

- ▷ System has not been initialized
- ▷ Driving on snowy or slippery road surface
- ▷ Performance-oriented style of driving: slip in the drive wheels, high lateral acceleration
- ▷ Snow chains are attached

Initialization

The initialization process adopts the set inflation tire pressures as reference values for the detection of a flat tire. Initialization is started by confirming the inflation pressures.

Do not initialize the system when driving with snow chains.

For operating principle refer to page 82.

1. Start the engine immediately before pulling away, but do not drive off yet.



2. Briefly press the button **1** in the turn signal/high beam lever up or down repeatedly until the corresponding symbol and "RESET" appear.
3. Press button **2** to confirm your choice of the Flat Tire Monitor.

- Press button **2** for approx. 5 seconds, until the reading shown below is displayed:



- Start driving. Initialization is completed while the car is on the move, without any feedback.

 The initialization is completed during driving, which can be interrupted at any time. When driving resumes, the initialization is continued automatically. ◀

Indication of a flat tire

 The warning lamps light up in yellow and red. In addition, an acoustic signal sounds. There is a flat tire or a major loss in tire pressure.

- Reduce speed and stop the vehicle with caution. Avoid sudden braking and steering maneuvers.

 If the vehicle is not equipped with run-flat tires, do not continue driving; continuing to drive can result in serious accidents. ◀

When a flat tire is reported, the Dynamic Stability Control DSC is activated.

Actions in the event of a flat tire

Run-flat tires

With a damaged tire, it is possible to continue driving at speeds of up to 50 mph/80 km/h.

When driving with a damaged tire:

- Avoid sudden braking and steering maneuvers.
- Do not exceed a speed of 50 mph/80 km/h.

- At the next opportunity, check the inflation pressure in all four tires.

If the inflation pressure in all four tires is correct, the Flat Tire Monitor might not have been initialized. The system must then be initialized.

Possible driving distance with complete loss of tire pressure:

The distance it is possible to drive with a flat tire depends on the load and the stress on the vehicle while driving.

With an average load, it may be possible to drive for approx. 50 miles/80 km.

When driving with damaged tires, the handling characteristics change, e.g. the vehicle will skid sooner when braking, braking distances will be longer, or self-steering response will change. Adapt your driving style accordingly. Avoid turning abruptly and driving over obstacles such as curbs, potholes, etc.

Since the possible driving distance depends to a considerable degree on the strain exerted on the vehicle while driving, it can be shorter or, with a gentle driving style, can also be longer, depending on the speed, road condition, outside temperature, vehicle load, etc.

 Drive cautiously and do not exceed a speed of 50 mph/80 km/h.

When there is a tire pressure loss, the handling characteristics change, e.g. there will be reduced directional stability during braking, braking distances will be longer, and self-steering response will change. ◀

 Vibrations or loud noises while driving can indicate final failure of the tire. Reduce your speed and bring the vehicle to a stop; otherwise, tire components may become detached, which could result in an accident. Do not continue driving; instead, contact your BMW center. ◀

Tire Pressure Monitor TPM

The concept

Check the inflation pressure in the four installed tires. The system notifies you if there is a significant loss of pressure in one or more tires.

Functional requirement

The system must have been reset while the inflation pressure was correct; otherwise, reliable signaling of a flat tire is not ensured. Always use wheels with TPM electronics to ensure that the system will operate properly. Each time a tire inflation pressure has been corrected or a wheel or tire has been changed, reset the system.

System limitations

 Sudden serious tire damage caused by external influences cannot be indicated in advance. ◀

The system does not function correctly if it has not been reset. For example, a flat tire may be indicated even though the tire inflation pressures are correct.

The system is inactive and cannot indicate a flat tire:

- ▷ When a wheel without TPM electronics is installed.
- ▷ Interference with TPM by other systems or devices with the same transmission frequency.

Resetting the system

Each time a tire inflation pressure has been corrected or a wheel or tire has been changed, reset the system.

For operating principle refer to page 82.

1. Start the engine, but do not start driving.
2. Briefly press the button 1 in the turn signal/high beam lever up or down repeatedly until

the corresponding symbol and "RESET" appear.



3. Press button 2 to confirm your choice of the Tire Pressure Monitor. The following display appears:



4. Press button 2 for approx. 5 seconds, until the small warning lamp lights up in yellow and the following appears in the display:



5. Start driving.

After several minutes of driving time, the adjusted inflation pressures will be adopted as nominal values. The resetting process is completed automatically as you drive. The indicator lamp goes out after the system reset is completed.

The trip can be interrupted at any time. When driving resumes, resetting continues automatically.

Message for low tire inflation pressure



The warning lamps light up in yellow and red. In addition, a signal sounds.



- ▷ There is a flat tire or substantial loss of tire pressure in the indicated wheel.
- ▷ The system was not reset after a wheel change and thus issues a warning based on the inflation pressures initialized last.

Reduce speed and stop the vehicle with caution. Avoid sudden braking and steering maneuvers.



If the vehicle is not equipped with run-flat tires, do not continue driving; continuing to drive can result in serious accidents. ◀

When a low tire pressure is reported, the Dynamic Stability Control DSC is activated.

Actions in the event of a flat tire

Run-flat tires

You can continue driving with a damaged tire at speeds up to 50 mph/80 km/h.

When driving with a damaged tire:

1. Avoid sudden braking and steering maneuvers.
2. Do not exceed a speed of 50 mph/80 km/h.
3. At the next opportunity, check the inflation pressure in all four tires.

If the inflation pressure is correct in all four tires, then the Tire Pressure Monitor may not have been reset. The system must then be reset.

Possible driving distance with complete loss of tire inflation pressure:

The distance it is possible to drive with a flat tire depends on the load and the stress on the vehicle while driving.

With an average load, it may be possible to drive for approx. 50 miles/80 km.

When driving with damaged tires, the handling characteristics change, e.g. the vehicle will skid sooner when braking, braking distances will be longer, or self-steering response will change. Adapt your driving style accordingly. Avoid turning abruptly and driving over obstacles such as curbs, potholes, etc.

Since the possible driving distance depends to a considerable degree on the strain exerted on the vehicle while driving, it can be shorter or, with a gentle driving style, can also be longer, depending on the speed, road condition, outside temperature, vehicle load, etc.



Drive cautiously and do not exceed a speed of 50 mph/80 km/h.

When there is a tire pressure loss, the handling characteristics change, e.g. there will be reduced directional stability during braking, braking distances will be longer, and self-steering response will change. ◀



Vibrations or loud noises while driving can indicate complete failure of the tire.

Reduce your speed and bring the vehicle to a stop; otherwise, tire components may become detached, which could result in an accident. Do not continue driving; instead, contact your BMW center. ◀

Malfunction



The small warning lamp flashes in yellow and then lights up continuously; the large warning lamp lights up in yellow. No punctures can be detected.



Display in the following situations:

- ▷ A wheel without TPM electronics has been installed:
Have it checked by your BMW center.
- ▷ Malfunction
Have the system checked.
- ▷ Tire Pressure Monitor was unable to complete the resetting process. Reset the system again.



The small warning lamp flashes in yellow and then lights up continuously; the large warning lamp lights up in yellow. No punctures can be

detected.

Display in the following situations:

- ▷ Interference from systems or devices that use the same radio frequency:
The system automatically becomes active again when the vehicle moves out of the interference zone.

Declaration according to NHTSA/FMVSS 138 Tire Pressure Monitoring Systems

Each tire should be checked monthly when cold and inflated to the inflation pressure recommended by the vehicle manufacturer on the vehicle placard or tire inflation pressure label. If your vehicle has tires of a different size than the size indicated on the vehicle placard or tire inflation pressure label, you should determine the proper tire inflation pressure for those tires. As an added safety feature, your vehicle has been equipped with a tire pressure monitoring system, TPMS, that illuminates a low tire pressure telltale when one or more of your tires are significantly underinflated. Accordingly, when the low tire pressure telltale illuminates, you should stop and check your tires as soon as possible, and inflate them to the proper pressure. Driving on a significantly underinflated tire causes the tire to overheat and can lead to tire failure. Underinflation also reduces fuel efficiency and tire tread life, and may affect the vehicle's handling and stopping ability. Please note that the TPMS is not a substitute for proper tire maintenance, and it is the driver's responsibility to maintain correct tire pressure, even if underinflation has not reached the level at which the TPMS low tire pressure telltale illuminates.

The TPMS malfunction indicator is combined with the low tire pressure telltale. When the system detects a malfunction, the telltale will flash for approximately one minute and then remain continuously lit. This sequence will continue

upon subsequent vehicle startups as long as the malfunction exists. When the malfunction indicator is illuminated, the system may not be able to detect or signal low tire pressure as intended. TPMS malfunctions may occur for a variety of reasons, including the installation of replacement or alternate tires or wheels on the vehicle that prevent the TPMS from functioning properly. Always check the TPMS malfunction telltale after replacing one or more tires or wheels on your vehicle to ensure that the replacement or alternate tires and wheels allow the TPMS to continue to function properly.

Active steering

The concept

Active steering varies the turning angle of the front wheels in relation to steering wheel movements. It also varies the steering force required to turn the wheels depending on the speed at which you are driving.

When you are driving in the low speed range, e.g. in a town or when parking, the steering angle is increased, i.e. steering becomes very direct and less effort is required to turn the wheels. In the higher speed range, on the other hand, the steering angle is reduced as the speed increases. This improves the handling of your BMW over the entire speed range.

In critical situations, the system can make targeted corrections to the steering angle provided by the driver and thus stabilize the vehicle before the driver intervenes. This stabilizing intervention is simultaneously deactivated when DSC is switched off, refer to page 91.

Malfunction



The warning lamps light up. Active steering is malfunctioning or is temporarily deactivated. At low speeds, greater steering wheel movements

are required, whereas at higher speeds the vehicle reacts more sensitively to steering wheel movements. The stability-enhancing feature may also be deactivated. Drive cautiously and think well ahead.

Deactivation

Active steering is deactivated to perform an initialization. A message indicates that the feature is deactivated. Initialization may take several minutes.

If the message does not disappear during the current trip, have the system checked.

Defect

If there is a defect, a corresponding message appears. Have the system checked.

Servotronic

The concept

The Servotronic varies the steering force required to turn the wheels relative to the vehicle speed.

At low speeds, the steering force is strongly assisted, i.e. less force is needed for steering. As the vehicle speed increases, the steering assisting power is reduced.

Malfunction



The warning lamp lights up. Servotronic is malfunctioning or has failed. Steering response will be different. You can continue your journey, but moderate your speed and exercise due caution. Have the system checked as soon as possible.

Brake Force Display



On the left: normal braking.

On the right: sharp braking.

Airbags

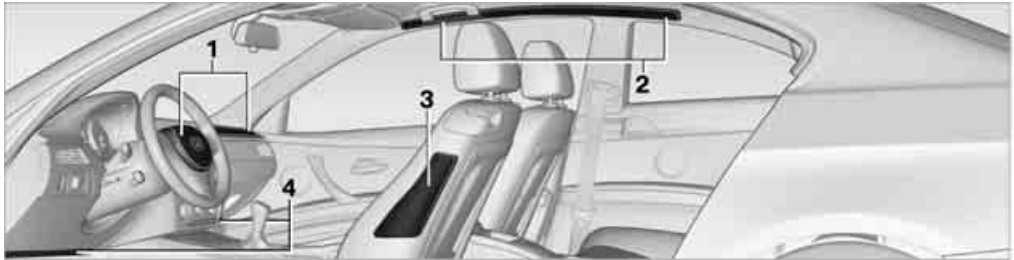

The following airbags are located under the marked covers:

- 1 Front airbags
- 2 Coupe: head airbags
- 3 Side airbags in the seat backrests
- 4 Convertible: knee airbags

Protective action

 Observe the adjustment instructions on page 42 to ensure the best possible personal protection. ◀

The front airbags help protect the driver and front passenger by responding to frontal impacts in which safety belts alone cannot provide adequate restraint. When needed, the head and side airbags help provide protection in the event of side impact. The relevant side airbag supports the side upper body area. The head air bag supports the head.

The airbags have been designed to not be triggered in every collision situation, e.g. not in minor accidents or rear-end collisions.

 Do not apply adhesive materials to the cover panels of the airbags, cover them or modify them in any other way.

Keep the dashboard and windows on the front passenger side clear, i.e. do not cover with adhesive labels or coverings, and do not attach holders such as for navigation instruments or mobile phones.

Do not attach seat covers, cushions or other objects not specifically approved for seats with integral side airbags to the front seats. Do not hang items of clothing such as coats or jackets over the backrests. Do not attempt to remove the airbag retention system from the vehicle. Do not modify the individual components of the system or its wiring in any way. This includes the upholstered covers on the steering wheel, instrument panel, seats and roof posts, as well as the sides of the roof lining. Do not attempt to remove or dismantle the steering wheel.

Do not touch the individual components immediately after the system has been triggered, because there is a danger of burns.

In the event of faults, immobilization, or after the airbag system has been triggered, have the testing, repair, or disassembly and scrapping of gas generators performed only by your BMW center or a workshop that has the required explosives licenses. Unprofessional attempts to work on the system could lead to failure in an emergency or to undesired airbag activation, either of which could result in personal injury. ◀

Warning notices and information about the airbags can also be found on the sun visors.

Automatic deactivation of the front passenger airbags

An analysis of the impression in the front passenger seat cushion determines whether and how the seat is occupied. The front and side airbags for the front passenger are activated or deactivated by the system accordingly.

 The indicator lamp above the interior rearview mirror shows the current status of the front passenger airbags, deactivated or activated, refer to Status of front passenger airbags below. ◀

 Before transporting a child on the front passenger seat, read the safety precautions and handling instructions under Transporting children safely, refer to page 53. The front and side airbags can also be deactivated by adolescents and adults sitting in certain positions; the indicator lamp for the front passenger airbags lights up. In such cases, the passenger should change his or her sitting position so that the front passenger airbags are activated and the indicator lamp goes out. If the desired airbag status cannot be achieved by changing the sitting position, transport the relevant passenger on a rear seat. Do not attach seat covers, seat cushion padding, ball mats or other items to the front passenger seat unless they are specifically recommended by BMW. Do not place any items under the seat which could press against the seat from below. Otherwise, a correct analysis of the seat cushion is not ensured. ◀

Status of front passenger airbags



The indicator lamp for the front passenger airbags shows the functional status of the front passenger front and side airbags in accordance with whether and how the front passenger seat is occupied. The indicator lamp shows whether the front passenger airbags are activated or deactivated.

- ▶ The indicator lamp lights up when a child in a specially designated child restraint system is detected, as intended, on the seat. The front and side airbags for the front passenger are not activated.
 -  Most child seats are detected by the system, This particularly applies to child seats that were required by NHTSA at the time of manufacture of the vehicle. After mounting a child seat, ensure that the indicator lamp for the front passenger airbag is lit. It indicates that the child seat has been detected and that the front passenger airbags are deactivated. ◀
- ▶ The indicator lamp does not light up as long as a person of sufficient size and in a correct sitting position is detected on the seat. The front and side airbags for the front passenger are activated.
- ▶ The indicator lamp does not light up if the seat is empty. The front and side airbags for the front passenger are not activated.

Operational readiness of airbag system



As of radio readiness, refer to page 57, the warning lamp lights up briefly to indicate that the entire airbag system and the belt tensioners are operational.

Airbag system malfunction

- ▷ Warning lamp does not light up at radio readiness or beyond.
- ▷ Warning lamp remains permanently on.

 In the event of a fault in the airbag system, have it checked without delay; otherwise, there is the risk that the system will not function as intended even if a sufficiently severe accident occurs. ◀

Convertible: rollover protection system

The rollover protection system is activated automatically in the event of an accident, a critical driving situation, an extreme tilt in the car's longitudinal axis or upon loss of ground contact. The protection bars behind the rear head restraints deploy within fractions of a second.

As a supplementary system to the reinforced windshield frame, the rollover protection system ensures that the necessary headroom is maintained for all vehicle occupants.

 Always keep the area of movement of the rollover protection system clear. In minor accidents, you are protected by the fastened safety belt and, depending on accident severity, by the safety belt tensioner and multi-phase airbag retention system. ◀

Resetting

If the rollover protection system was not impacted after being automatically activated, it can be reset by lowering the protection bars to their original positions. This does not require tools.

1. Push the locking lever to one side and hold it there.

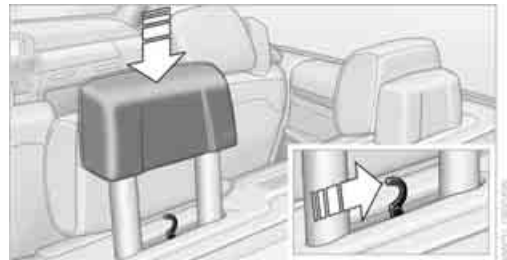

2. Push the protection bar halfway down from above.
3. Release the locking lever.
4. Push the protection bar down until it snaps into place.

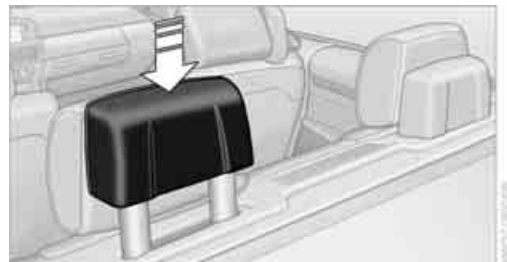

5. Repeat the procedure for the other protection bar.

Have the rollover protection system checked after an unexpected activation.



Never move the retractable hardtop when the rollover protection system is in the activated position.

Do not make any modifications to the individual components of the rollover protection system or its cabling.

Work on the rollover protection system should be performed only by your BMW center.

Incorrectly performed work on the system may lead to system failure or incorrect operation.

To check the system and ensure flawless long-term operation, always observe the service intervals, refer to page [84](#). ◀

Lamps

Vehicle equipment

In this chapter, all production, country, and optional equipment that is offered in the model range is described. For this reason, descriptions will be given of some equipment that may not be available in a vehicle, for example due to the special options or national-market version selected. This also applies to safety related functions and systems.

At a glance

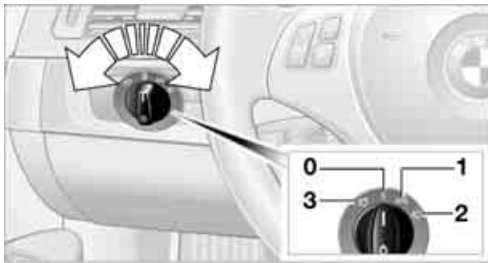

- 0** Lamps off, daytime running lights
- 1** Parking lamps and daytime running lights
- 2** Low beams, welcome lamps
- 3** Automatic headlamp control, daytime running lights, welcome lamps, High-beam Assistant, and Adaptive Light Control

Parking lamps/low beams, automatic headlamp control

General information

When the driver's door is opened with ignition switched off, then the exterior lighting is automatically switched off if the light switch is in position **0**, **2**, or **3**.

Parking lamps

In switch position **1**, the front, rear and side vehicle lighting is switched on. You can use the parking lamps for parking.

 The parking lamps will discharge the battery. Therefore, do not leave them on for unduly long periods of time; otherwise, the battery might not have enough power to start the engine. It is preferable to switch on the left-hand or right-hand roadside parking lamps, refer to page [105](#). ◀

Low beams

The low beams light up when the light switch is in position **2** and the ignition is on.

Automatic headlamp control

When the switch is in position **3**, the low beams are switched on and off automatically depending on ambient lighting conditions, e.g. in a tunnel, in twilight, or if there is precipitation. The Adaptive Light Control is active. The LED next to the symbol is illuminated when the low beams are on. You can also activate the daytime running lights, refer to page [104](#). In the situations described above, the lamps then automatically switch from daytime running lights to low beams.

The headlamps may also come on when the sun is sitting low on a blue sky.

 The low beams remain switched on independent of the ambient lighting conditions when you switch on the fog lamps. ◀

 The automatic headlamp control cannot serve as a substitute for your personal judgment in determining when the lamps should be switched on in response to ambient lighting conditions. For example, the system cannot detect fog or hazy weather. To avoid safety risks, you should always switch on the low-beam headlamps manually under these conditions. ◀

Welcome lamps

If you leave the light switch in position **2** or **3** when you park the car, the parking lamps and the interior lamps light up briefly when you unlock the vehicle.

Pathway lighting

If the headlamp flasher is activated after switching off the ignition with the lamps switched off, the low beams come on and remain on for a certain time.

Setting duration

For operating principle, refer to page [82](#).

1. Switch on the ignition, refer to page [57](#).
2. Briefly press button **1** in the turn signal/high beam lever up or down repeatedly until the symbol appears in the display, accompanied by the word "SET".



3. Press button **2**.
4. Briefly press button **1** in the turn signal/high beam lever down repeatedly until the symbol appears in the display.



5. Press button **2**.

6. Use button **1** to select:
 - ▷ **0 s**
The function is deactivated.
 - ▷ **10 s ... 240 s**
Select the appropriate duration, e.g. 40 seconds.

7. Press button **2**.
The setting is stored for the remote control currently in use.

Daytime running lights

The daytime running lights light up in switch position **0**, **1** and **3**. They are less powerful than the low beams.

The tail lamps may also light up.

Activating/deactivating daytime running lights

For operating principle, refer to page [82](#).

1. Switch on the ignition, refer to page [57](#).
2. Briefly press button **1** in the turn signal/high beam lever up or down repeatedly until the symbol appears in the display, accompanied by the word "SET".



3. Press button **2**.
4. Briefly press button **1** in the turn signal/high beam lever down repeatedly until the symbol appears in the display.



5. Press button **2**.
6. Use button **1** to select:
 - ▷ **ALC on**
Daytime running lights activated.
 - ▷ **ALC off**
Daytime running lights deactivated.
7. Press button **2**.
The setting is stored for the remote control currently in use.

Adaptive Light Control

The concept

Adaptive Light Control is a variable headlamp control system that enables better illumination of the road surface. Depending on the steering angle and other parameters, the light from the headlamp follows the course of the road.

In tight curves at speeds up to 40 mph/70 km/h, e.g. on mountainous roads or when turning, an additional, corner-illuminating lamp is switched on that lights up the inside area of the curve.

Activating Adaptive Light Control

With the ignition switched on, turn the light switch to position **3**, refer to page 103.

The corner-illuminating lamp is switched on automatically, depending on the steering wheel angle or turn signal indicator.

Standstill function: to avoid blinding oncoming traffic, the Adaptive Light Control directs light toward the front passenger side when the vehicle is at a standstill.

When you are reversing, only the corner-illuminating lamps are switched on and active on both sides.

Malfunction



The warning lamp lights up. The Adaptive Light Control is malfunctioning or failed. Have the system checked as soon as possible.

High beams/roadside parking lamps

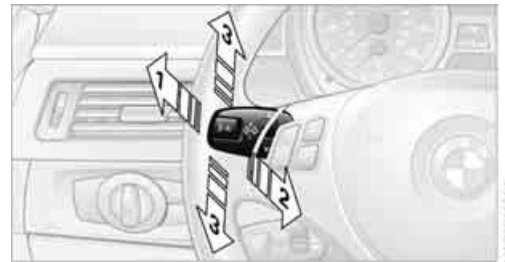

- 1 High beams
- 2 Headlamp flasher
- 3 Roadside parking lamps

Roadside parking lamps, left or right

There is an additional option of switching on the lamps on the side of the car facing the road when parked.

Switching on

After parking the vehicle, press the lever up or down beyond the pressure point for a longer period, arrow **3**.



The roadside parking lamps drain the battery. Therefore, do not leave them on for unduly long periods of time; otherwise, the battery might not have enough power to start the engine. ◀

Switching off

Press the lever in the opposite direction to the pressure point, arrow **3**.

High-beam Assistant

The concept

This system automatically switches the high beams on and off. The procedure is controlled by a sensor on the front of the interior rearview mirror. The assistant ensures that the high beams are switched on whenever the traffic situation allows. It handles this task for you and gives you the benefit of the best possible view. You can intervene at any time and switch the high beams on and off as usual.

Activating the system

1. Turn the light switch to position **3**, refer to page 103.
2. With the low beams switched on, briefly push the turn signal/high beam lever in the direction of the high beam.



The indicator lamp in the instrument cluster lights up when the high beams are activated. The system automatically switches from high beams to low beams and vice versa in response to oncoming traffic, traffic ahead of you, and adequate ambient lighting, e.g. on city streets.

Switching the high beams on and off manually

Whenever you wish, or when the situation requires, you can intervene:

- ▷ If the High-beam Assistant switches on the high beams, but you would like to drive with the low beams, simply switch off the high beams using the turn signal/high beam lever. This deactivates the High-beam Assistant.

To reactivate the system, briefly push the turn signal/high beam lever toward the high beams again.

- ▷ If the High-beam Assistant switches on the low beams, but you would like to drive with the high beams, switch on the high beams as usual. This deactivates the system and the high beams need to be switched off manually, if necessary.

To reactivate the system, briefly push the turn signal/high beam lever toward the high beams again.

- ▷ Use the headlamp flasher as usual with the low beams switched on.

System limitations



The High-beam Assistant cannot serve as a substitute for the driver's personal judgment of when to use the high beams.

Therefore, manually switch off the high beams in situations where this is required to avoid a safety risk. ◀

The system is not fully functional in situations such as the following, and driver intervention may be necessary:

- ▷ In very unfavorable weather conditions, such as fog or heavy precipitation
- ▷ In detecting poorly-lit road users, such as pedestrians, cyclists, horseback riders and wagons; when driving close to train or ship traffic; and at animal crossings
- ▷ In tight curves, on hilltops or in depressions, in cross traffic or half-observed oncoming traffic on highways
- ▷ In poorly lit towns and cities and in the presence of highly reflective signs
- ▷ At low speeds
- ▷ When the windshield in front of the interior rearview mirror is fogged over, dirty or covered with stickers, etc.
- ▷ If the sensor is dirty. Clean the sensor on the front of the interior rearview mirror using a cloth moistened with a small amount of glass cleaner.

Fog lamps



 The parking lamps or low beams must be switched on for the fog lamps to operate. The green indicator lamp in the instrument cluster lights up whenever the fog lamps are on.

The fog lamps are switched off while you activate the headlamp flasher or switch on the high beams.

 If the automatic headlamp control is activated, the low beams will come on automatically when you switch on the fog lamps. ◀

Instrument lighting

You can adjust the brightness of the instrument lighting only when the parking lamps or the low beams are switched on.



1. Push button **1** up or down repeatedly until the appropriate symbol appears in the display, accompanied by the brightness setting and scale the word "SET".
2. Press button **2**.



3. Push button **1** up or down to select the desired brightness level.
4. Press button **2**.
The display again shows the outside temperature and the time.

Interior lamps

The interior lamps, the footwell lamps, entry lamps, cargo area lamp, and courtesy lamps are controlled automatically.

The LEDs for the courtesy lamps are set in the door handles and illuminate the ground in front of the doors.

 To reduce the drain on the battery, a few minutes after the radio readiness is switched off, refer to Start/Stop button on page 57, all lights in the vehicle's passenger compartment are switched off. ◀

Switching interior lamps on/off manually



Interior lamps, front and rear:
To switch on and off, press the button.

To switch off the interior lamps, footwell lamps, entry lamps, and courtesy lamps permanently, press the button for the front interior lamps for about 3 seconds.

Reading lamps

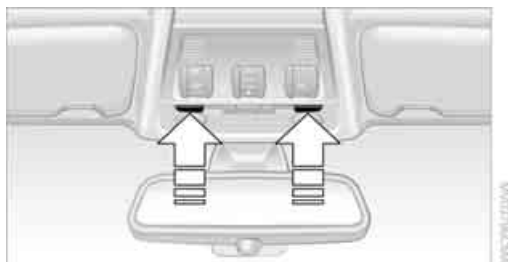

There are reading lamps at the front and rear, next to the interior lights. To switch on and off, press the button.

Climate

Vehicle equipment

In this chapter, all production, country, and optional equipment that is offered in the model range is described. For this reason, descrip-

tions will be given of some equipment that may not be available in a vehicle, for example due to the special options or national-market version selected. This also applies to safety related functions and systems.

Overview



Equipment versions

Depending on the equipment version, your car has an air conditioner or an automatic climate control system.

- 1 Air conditioner [110](#)
- 2 Automatic climate control [112](#)

Air vents

- 3 Airflow directed toward the windshield and side windows
 - 4 Air to the upper body area.
The thumbwheels smoothly open and close
 - 5 Air to the footwell
- the air supply. The levers alter the direction of the airflow. For further details on draft-free ventilation, refer to page 115.





Air conditioner



- 1 Air distribution
- 2 Recirculated air mode
- 3 Air volume
- 4 Cooling function
- 5 Temperature
- 6 Rear window defroster

Air distribution



Direct the flow of air to the windows , to the upper body area  or to the footwell . Intermediate settings are possible. In the center position between  and , the air is also deflected at toward the windows.

Recirculated air mode



If the air outside the car has an unpleasant odor or contains pollutants, shut off the supply to the interior of the car temporarily. The system then recirculates the air currently within the vehicle.

You can also activate/deactivate the recirculated air mode by means of a button on the steering wheel, refer to page 11.

 If the windows fog in recirculated air mode, switch off the recirculated air mode and increase the air volume if necessary. The recirculated air mode should not be used

over an extended period of time; otherwise, the air quality in the passenger compartment will deteriorate continuously. ◀

Air volume



Turn to adjust the air volume. The higher the volume, the more effective the heating or cooling will be.

The air flow rate is lowered or switched off entirely to reduce the drain on the battery.

Switching the system on/off

Set any desired air volume to switch on the air conditioner.

Turn the air volume rotary switch to 0. The blower and air conditioner are completely switched off and the air supply is cut off.

 The outside air supply is blocked when the air conditioner is switched off. If the air quality deteriorates or the window fogs over,

switch the system back on and increase the air volume. ◀

Switching cooling function on/off



The cooling function cools and dehumidifies the incoming air before reheating it according to the temperature setting. This function is only available while the engine is running.

The cooling function helps prevent condensation on the windows or removes it quickly.

The cooling effect can be intensified by activating recirculated air mode.

Depending on the weather, the windshield may fog over briefly when the engine is started.

Rear window defroster



The defroster is switched off automatically after a certain time.

Depending on your vehicle's equipment, the upper wires serve as an antenna and are not part of the rear window defroster.

Temperature





To increase the temperature, turn the rotary switch clockwise towards red.

For a lower temperature, turn the rotary switch counterclockwise towards blue.

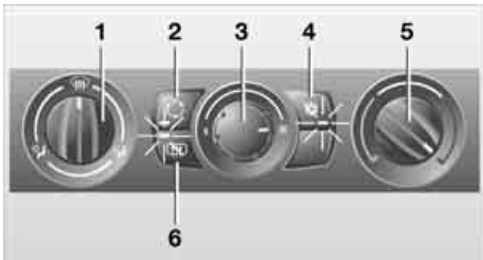
Defrosting windows and removing condensation



1. Air distribution **1** in position .
2. Deactivate recirculated air mode **2**.

3. Air volume control **3** all the way to the right.
4. Switch on cooling function **4**.
5. Temperature **5** to the right, red.
6. Switch on rear window defroster **6** to defrost the rear window .

Ventilation

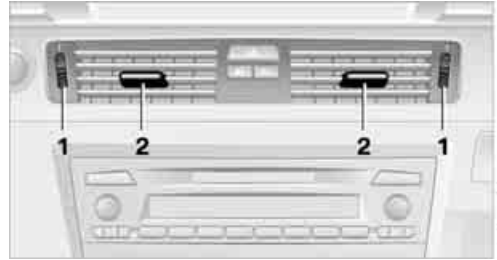

- 1 Use the thumbwheels to smoothly open and close the air vents
- 2 Use the levers to change the direction of the airflow

Ventilation for cooling

Adjust the vent outlets to direct the flow of cool air in your direction, e.g. if it has become too hot in the car.

Draft-free ventilation

Adjust the vents to let the air flow past you.

Microfilter

The microfilter removes dust and pollen from the incoming air. Your BMW center replaces the microfilter during routine maintenance.

Automatic climate control



- | | |
|---|---|
| <ul style="list-style-type: none"> 1 Seat heating, left side 48 2 Air distribution, manual 3 Temperature, left side 4 Maximum cooling 5 AUTO program 6 Air volume, manual adjustment; AUTO intensity 7 Automatic recirculated air control AUC/ Recirculated air mode | <ul style="list-style-type: none"> 8 ALL program 9 Temperature, right side 10 Defrosting windows and removing condensation 11 Switching cooling function on/off manually 12 Rear window defroster 13 Seat heating, right side 48 14 Interior temperature sensor, please keep clear |
|---|---|

Comfortable interior climate

AUTO program **5** offers the ideal air distribution and air volume for almost all conditions, refer to AUTO program below. All you need to do is select an interior temperature which is comfortable for you.

The following sections inform you in detail about how to adjust the settings.

Most settings are stored for the remote control currently in use, refer also to Personal Profile settings on page 25.

Adjusting air distribution manually



The air distribution can be switched on and off manually. The air is directed to the windshield, to the upper body area and to the footwell.

The automatic air distribution can be switched back on by pressing the AUTO button. The cooling function is switched on automatically

and the manual air distribution setting is cleared.

Temperature



Turn to set the desired temperature.

The automatic climate control achieves this temperature as quickly as possible regardless of the season, using maximum cooling or heating power if necessary, and then maintains it.

Avoid rapid switching between different temperature settings. The automatic climate control will not have sufficient time to adjust the set temperature.

Maximum heating power can be obtained with the highest setting, regardless of the outside temperature.

The system cools steadily in the lowest setting, regardless of the outside temperature.

Maximum cooling



Press the button.

The system is set to the lowest temperature, maximum air volume and recirculated air mode.

Air flows out of the vent outlets for the upper body region. Open them for this purpose.

Air is cooled as quickly as possible:

- ▷ Above an outside temperature of approx. 32 °F / 0 °C
- ▷ When the engine is running

AUTO program



Press the button.

Air volume, air distribution and temperature are controlled automatically.

Depending on the selected temperature, AUTO intensity and outside influences, the air is directed toward the windshield, the side windows, the upper body and the footwell.

Pressing the AUTO button automatically switches on the cooling function.

At the same time, a condensation sensor controls the program so as to prevent window condensation as much as possible.

The program is switched off when the air distribution is set manually or the button is pressed again.

Intensity of the AUTO program

With the AUTO program switched on, automatic control of the air volume and air distribution can be adjusted:



Press the left side of the button to reduce the intensity. Press the right side of the button to

increase it.

The selected intensity is shown on the display of the automatic climate control.

Convertible program

The Convertible program is active when the hardtop is open. In the Convertible program, the automatic climate control is optimized for driving with the hardtop open. In addition, the air volume is increased as vehicle speed increases.



The effectiveness of the Convertible program can be enhanced considerably by installing the wind deflector. ◀

Adjusting air volume manually

To be able to manually adjust the air volume, switch off the AUTO program first.



Press the left side of the button to reduce the air volume. Press the right side of the button to

increase it.

The air flow rate is lowered or switched off entirely to reduce the drain on the battery. The display remains the same.

Automatic recirculated air control AUC/Recirculated air mode

You can respond to unpleasant odors or pollutants in the immediate environment by temporarily suspending the supply of outside air. The system then recirculates the air currently within the vehicle.



Press the button repeatedly to select an operating mode:

- ▷ LED off: outside air flows in continuously.
- ▷ Left-hand LED on, AUC mode: a sensor detects pollutants in the outside air and controls the shut-off automatically.
- ▷ Right-hand LED on, recirculated air mode: the supply of outside air is permanently shut off. If the windows fog over, switch off recirculated air mode and increase the air volume, if necessary. Make sure that air can flow onto the windshield.

 The recirculated air mode should not be used over an extended period of time; otherwise, the air quality inside the car will deteriorate continuously. ◀

Via the button on the steering wheel

You can switch quickly between the recirculated air mode and the previous mode using a button on the steering wheel, refer to page 11.

ALL program



Press the button.

The current temperature setting on the driver's side is transferred to the front passenger side.

If the temperature setting on the driver's side is changed, the temperature on the front passenger side is changed as well.

The program is switched off when the setting is adjusted on the front passenger side or the button is pressed again.

Defrosting windows and removing condensation



Press the button.

Quickly removes ice and condensation from the windshield and

front side windows.

For this purpose, also switch on the cooling function.

Switching cooling function on/off

The passenger compartment can only be cooled while the engine is running.



Press the button.

The air is cooled and dehumidified and – depending on the temperature setting – warmed again.

Depending on the weather, the windshield may fog up briefly when the engine is started.

Pressing the AUTO button automatically switches on the cooling function.

Rear window defroster



Press the button.

The defroster is switched off automatically after a certain time.

Depending on your vehicle's equipment, the upper wires serve as an antenna and are not part of the rear window defroster.

Switching the system on/off

Switching off



With the blower at its lowest setting, press the left side of the button to switch off the automatic climate control.

All displays are cleared except for the rear window defroster if it is switched on.



The outside air supply is blocked when the automatic climate control is switched off. If the air quality deteriorates or the window fogs over, switch the system back on and increase the air volume. ◀

Switching on

Press any button except the ALL or the rear window defroster button to reactivate the automatic climate control.

Ventilation

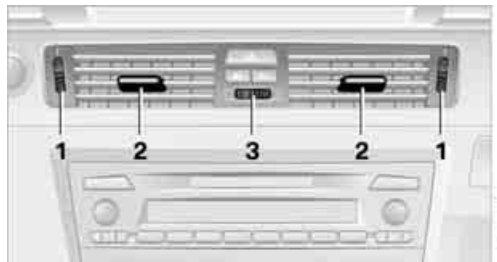

- 1 Use the thumbwheels to smoothly open and close the air vents
- 2 Use the levers to change the direction of the airflow
- 3 Thumbwheel for more or less cool air from the vents for the upper body area

Ventilation for cooling

Adjust the vent outlets to direct the flow of cool air in your direction, e.g. if it has become too hot in the car.

Draft-free ventilation

Set the vent outlets so that the air flows past you and not straight at you.

Ventilation in the rear

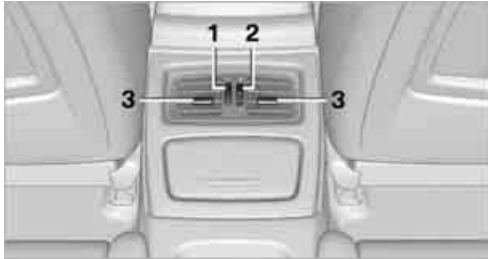

- 1 Use the thumbwheel to adjust the temperature:
 - ▷ Turn toward blue: colder
 - ▷ Turn toward red: warmer
- 2 Use the thumbwheel to smoothly open and close the air vents
- 3 Use the lever to change the direction of the airflow

Microfilter/activated-charcoal filter

The microfilter traps dust and pollen in the incoming air. The activated-charcoal filter provides additional protection by filtering gaseous pollutants from the outside air. Your BMW center replaces this combined filter during routine maintenance.

Practical interior accessories

Vehicle equipment

In this chapter, all production, country, and optional equipment that is offered in the model range is described. For this reason, descriptions will be given of some equipment that may not be available in a vehicle, for example due to the special options or national-market version selected. This also applies to safety related functions and systems.

Integrated universal remote control

The concept

The Integrated universal remote control can be used to operate up to 3 functions of remote-controlled devices such as garage door openers or lighting systems. The Integrated universal remote control thus replaces as many as three different hand-held transmitters. To operate them, the buttons on the interior rearview mirror must be programmed with the desired functions. Programming requires the hand-held transmitter for the respective device.

 To prevent possible damage or injury, before programming or using the integrated universal remote control to operate a device, always inspect the immediate area to make certain that no people, animals or objects are within the pivoting or travel range of the device being operated.

Also follow the safety instructions supplied with the hand-held transmitter. ◀

For security reasons, make sure to delete the stored functions before selling the vehicle, refer to page 118.

Compatibility



If this symbol appears on the package or in the instructions supplied with the device to be operated, you can generally assume that the device is compatible with the Integrated universal remote control.

For additional questions, please consult:

- ▷ Your BMW center.
- ▷ www.homelink.com on the Internet.

HomeLink is a registered trademark of Johnson Controls, Inc.

Controls on the interior rearview mirror

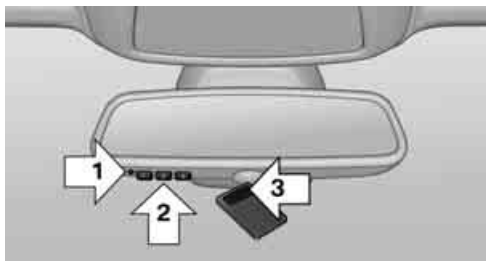

- 1 LED
- 2 Buttons
- 3 Hand-held transmitter, required for programming.

Programming

General information

1. Switch on the ignition.
2. Initial operation:
Simultaneously hold down the right and left buttons on the inside mirror for approx. 20 seconds until the LED on the inside mirror flashes.

All programs of the buttons on the rearview mirror are deleted.

3. Hold the hand-held transmitter of the device to be controlled approx. 1 in/2.5 cm to 3 in/8 cm away from the buttons on the inside mirror.

The required distance depends on the hand-held transmitter.

4. Simultaneously press and hold the button of the desired function on the hand-held transmitter and the button to be programmed on the inside mirror.

The LED on the inside mirror will flash slowly at first.

5. As soon as the LED flashes rapidly, release both buttons. The rapid flashing indicates that the button on the inside mirror has been programmed.

If the LED does not flash rapidly within 60 seconds, change the distance between the inside mirror and the hand-held transmitter and repeat this step. This may require several attempts. Allow at least 15 seconds between attempts.

6. To program additional functions on the other buttons of the inside mirror, repeat steps 3 through 5.

The buttons on the inside mirror can be used to operate the devices if the ignition is switched on.

Special procedure with alternating-code systems

If the device fails to function even after repeated programming, check whether the device to be controlled uses an alternating-code system.

To do so, either read the instructions for the device or hold down the programmed button on the inside mirror. If the LED on the inside mirror flashes quickly at first and then remains lit for 2 seconds, the device uses an alternating-code system. The LED flashes and lights up repeatedly for approx. 20 seconds.

In devices with an alternating-code system, the Integrated universal remote control and the device must also be synchronized.

For information about synchronizing can also be found in the operating instructions for the device to be set.

Programming will be easier with the aid of a second person.

Synchronizing:

1. Park your vehicle within the range of the remote-controlled device.
2. Program the Integrated universal remote control as described above.
3. Locate and press the synchronization button on the device to be set. You have approx. 30 seconds to perform the next step.
4. Hold down the programmed button on the inside mirror for approx. 3 seconds and then release it. Repeat this operation, up to three times if necessary, to complete the synchronization. If the synchronization has succeeded, the programmed function is performed.

Reprogramming individual buttons

1. Switch on the ignition.
2. Hold the hand-held transmitter of the device to be controlled approx. 1 in/2.5 cm bis 3 in/8 cm away from the buttons on the inside mirror.

The required distance depends on the hand-held transmitter.

3. Press the desired button on the inside mirror.
4. If the LED on the inside mirror flashes slowly after approx. 20 seconds, press the transmit key of the hand-held transmitter.
5. As soon as the LED flashes rapidly, release both buttons.

If the LED does not flash rapidly after approx. 60 seconds, alter the distance and repeat the step.

Canada: if the LED does not flash rapidly after approx. 60 seconds, alter the distance and repeat this step or, if the programming by means of the hand-held transmitter was interrupted, hold down the button on the inside mirror and then press and release the button on the hand-held transmitter several times, holding it down for 2 seconds each time.

Operation

 To prevent possible damage or injury, before programming or using the integrated universal remote control to operate a device, always inspect the immediate area to make certain that no people, animals or objects are within the pivoting or travel range of the device being operated.

Also follow the safety instructions supplied with the hand-held transmitter. ◀

The button on the inside mirror can be used to operate the device, for example the garage door, if the engine is running or the ignition is switched on. To do so, within the reception range of the device, press the button of the device until the function is triggered. The LED on the inside mirror remains lit during transmission of the radio signal.

Deleting stored functions

Simultaneously hold down the right and left buttons on the inside mirror for approx. 20 seconds until the LED on the inside mirror flashes rapidly. All stored functions are deleted. The functions cannot be deleted individually.

Digital compass

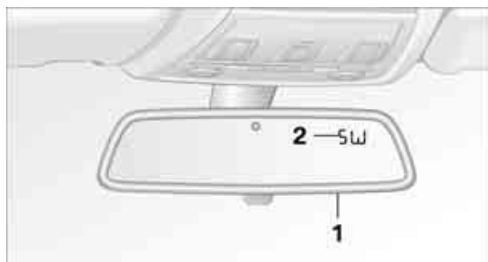

- 1 Adjustment button
- 2 Display

The display shows you the main or secondary compass direction in which you are driving.

Operating principle

You can call up various functions by pressing the adjustment button with a pointed object such as a pen or similar item. The following adjustment options are displayed one after the other, depending on how long you keep the adjustment button pressed:

- ▷ Press briefly: switch display on/off
- ▷ 3 to 6 seconds: set compass zone
- ▷ 6 to 9 seconds: calibrate compass
- ▷ 9 to 12 seconds: set left-hand/right-hand steering
- ▷ 12 to 15 seconds: set the language

Setting compass zones

Set the compass zone corresponding to your vehicle's geographic location so that the com-

pass can function correctly; refer to the world map with compass zones.

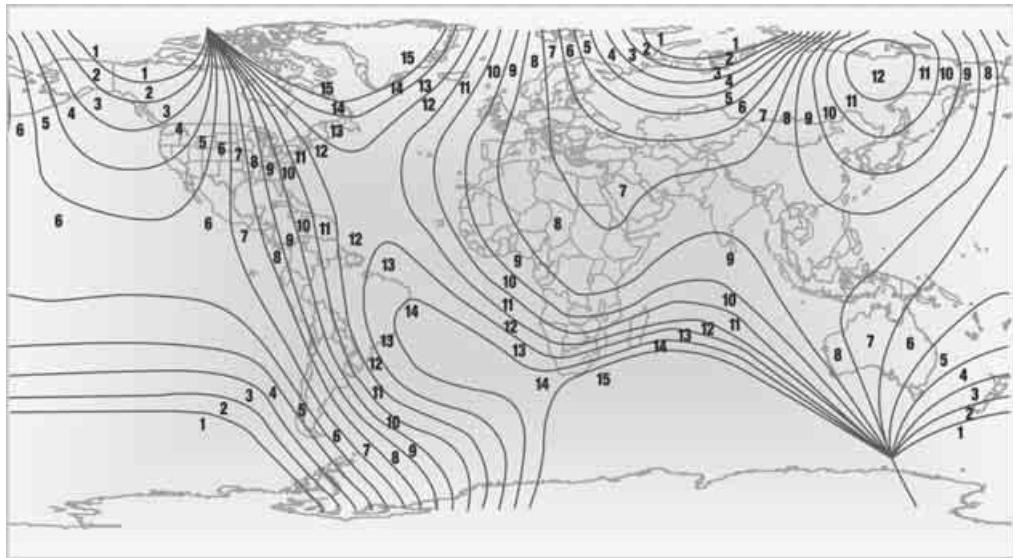

To set the compass zone, press the adjustment button for approx. 3-4 seconds. The number of the compass zone set is shown in the display.

To change the zone setting, briefly press the adjustment button repeatedly until the display shows the number of the compass zone corresponding to your current location.

The compass is operational again after approx. 10 seconds.

Calibrating the digital compass

The digital compass must be calibrated in the following situations:

- ▷ An incorrect compass direction is shown.
- ▷ The compass direction shown does not change although the direction of travel does.
- ▷ Not all compass directions are shown.

Procedure

1. Make sure that no large metal objects or overhead power lines are in the vicinity of your vehicle and that you have enough space to drive in a circle.
2. Set the currently valid compass zone.
3. Convertible: ensure that the retractable hardtop is fully closed.
4. Press the adjustment button for approx. 6-7 seconds to call up C. Then drive in at least one full circle at a speed of no more than 4 mph/7 km/h. If calibration is successful, the display changes from C to a compass direction.
5. Convertible: open the retractable hardtop fully and repeat step 4.

Setting right-hand/left-hand steering

Your digital compass is factory-set to right-hand or left-hand steering, in accordance with your vehicle.

Set the language

You can set the language of the display:

Press the adjustment button for approx. 12-13 seconds. Press the adjustment button again briefly to switch between English "E" and German "O".

The setting is automatically saved after approx. 10 seconds.

Coupe: Roller sunblinds

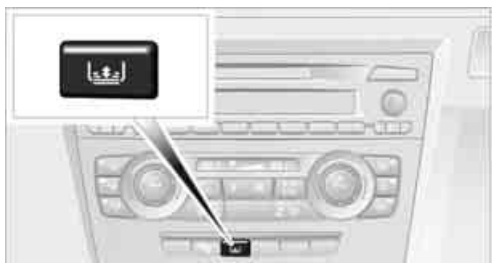

Briefly press the button in the center console to raise or lower the roller sunblind.

Glove compartment

Opening



Pull the handle.

The light in the glove compartment comes on.



To prevent injury in the event of an accident while the vehicle is being driven, close the glove compartment immediately after use. ◀

Closing

Fold the cover up.

Locking

To lock the glove compartment, use the integrated key of the remote control, refer to page 24.

Convertible: when you lock the vehicle from the outside, the glove compartment is locked as well.

Center armrest

Storage compartment

The center armrest between the front seats contains either a compartment or the cover for the snap-in adapter, depending on the equipment version.

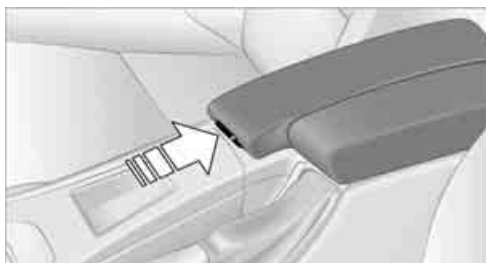

Opening

Press the button, see arrow.

Adjustments



Slide the center armrest on the driver's side into the desired position.

Connection for external audio device

You can connect an external audio device such as a CD or MP3 player and play audio tracks over the vehicle speakers:

- ▷ AUX-IN port, refer to page 151
- ▷ USB audio interface, refer to page 151.

Storage compartments inside the vehicle

Depending on your vehicle's equipment, you will find compartments beside the steering column, in the front doors and in the center console.

Nets are provided on the front-seat backrests.

 Do not place unsecured objects in them; otherwise, they could endanger the car's occupants, e.g. in the event of braking or evasive maneuvers. ◀

 Do not place non-slip pads, e.g. anti-slip mats, on the dashboard; the materials of these pads may damage it. ◀

Storage compartments in the rear console

Depending on your vehicle's equipment version, the following storage compartments can be found in the rear console:



- ▷ Storage tray
- ▷ Storage compartment with cover
- ▷ Cupholders

Coupe: clothes hooks

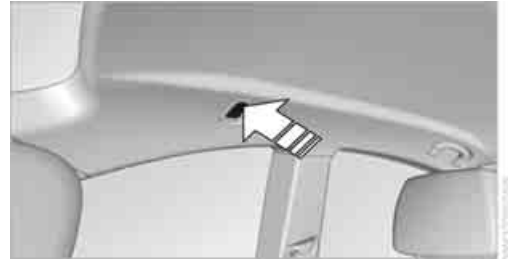

Press the upper edge to flip open.

 Items of clothing hung from the hooks must not obstruct the driver's view. Do not hang heavy objects from the hooks; otherwise, they could endanger the car's occupants, e.g. in case of heavy braking or sudden swerving. ◀

Cupholders

 Use lightweight and shatterproof containers and do not transport hot beverages; otherwise, there is an increased risk of injury in the event of the accident. Do not force containers that are too large into the cupholders; otherwise, damage could result. ◀

Front

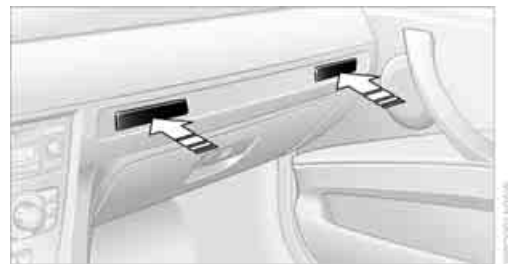

Opening

Briefly press the center of the cover.

Closing

Briefly press the cover in the center and push in the cupholder.

Coupe: rear

There are two additional cupholders in the rear center armrest.



Press the front of the armrest.

Convertible: rear

There are two additional cupholders in the rear console.

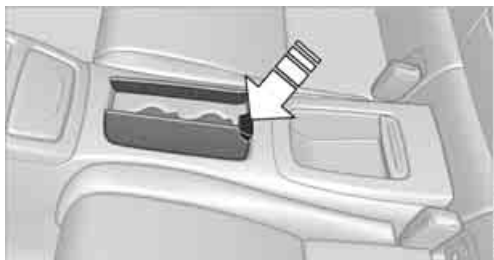

Press the button to open.

! Before folding down the rear seat backrest or using the transport bag, remove all containers from the cupholder and close it. Do not place objects into the cupholder and use force to close it. Do not use the cupholder as a grab handle. ◀

Ashtray

Opening



Push the ridge on the cover.

Emptying



Lift out the insert.

Lighter



With the engine running or the ignition switched on, press in the cigarette lighter.

The lighter can be pulled out as soon as it pops back out.

! Hold or touch the hot cigarette lighter by the knob only. Holding or touching it in other areas could result in burns. When leaving the car, always remove the remote control so that children cannot operate the cigarette lighter and burn themselves. ◀

Connecting electrical appliances

In your BMW, when the engine is running or the ignition is switched on, you can use electrical devices such as a hand lamp, car vacuum cleaner, etc. if at least one of the following sockets is available.

The total load of all sockets should not exceed 140 watts at 12 volts.

Avoid damaging the sockets by attempting to insert plugs of unsuitable shape or size.

! Do not connect battery chargers to the sockets built into the vehicle at the plant; doing so may damage the vehicle. ◀

Cigarette lighter socket

To access the socket: take the cigarette lighter out of the socket.

Socket in the front passenger footwell

A socket is located under the glove compartment on the left.

Socket in the center armrest

External audio device, refer to page 121.

Coupe: socket in cargo area



Open the cap.

Coupe: Through-loading system

Opening



1. To release the rear seat backrest, pull the corresponding lever in the cargo area.
2. The unlocked rear seat backrest moves forward slightly. Fold the backrest forward by the head restraint.



Closing

Return the rear seat backrest to its upright position and engage it.

 When returning the backrest to its seating position, make sure that the seat's locking mechanism engages properly. Otherwise, cargo could be thrown around in the event of sharp braking or swerving and endanger the occupants. ◀

The lashing eyes in the cargo area provide you with a way to attach cargo area nets or draw straps for securing suitcases and luggage, refer to page 137.

Convertible: Cargo loading

Enlarging the cargo area

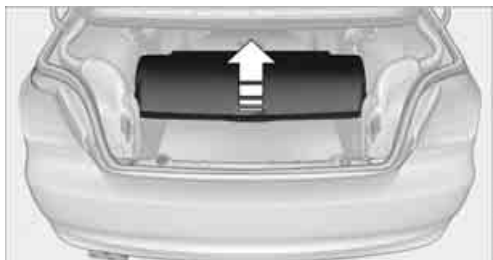

When the hardtop is closed you can enlarge the cargo area:

To do so, push the cargo area partition upward.

Before opening the hardtop, push the cargo area partition down until it engages on both sides.

 Before moving the hardtop, ensure that there are no objects on or next to the cargo area partition; otherwise, parts of the hardtop may be damaged. Do not exceed the maximum loading height; refer to the sticker in the cargo area showing a line indicating the maximum height. Do not use force to push down the cargo area partition. ◀

 The retractable hardtop can only be opened if the cargo area partition is in its lowermost position and engaged on both sides. ◀

Folding down the rear seat backrest

Opening



You can fold down the rear seat backrest to transport light objects in the rear without damaging the seats. Depending on the vehicle equipment, the mounting points for the cargo area net are found on the rear panel of the backrest. To unlock the rear seat backrest: press the button on the driver's or the opposite side.

Closing

Return the rear seat backrest to the upright seating position and engage it.

 When returning the backrest to its seating position, make sure that the seat's locking mechanism engages properly. Otherwise, cargo could be thrown around in the event of sharp braking or swerving and endanger the occupants. ◀

Bag holder

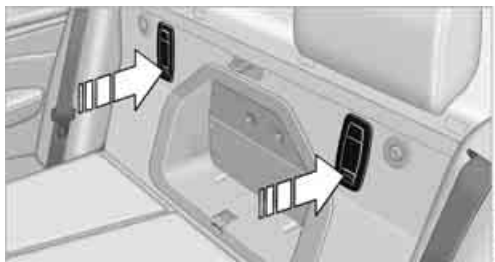

When the rear seat backrest is folded down, you will find two bag holders on the cargo area wall:

1. Fold open the holder by pressing the button.
2. Press the handles of the bag onto the holder from above.

 Only hang light shopping bags or other suitable objects from the holders; otherwise, braking maneuvers and swerving, for example, may lead to a safety hazard due to objects flying about the passenger compartment. Only transport heavy luggage in the cargo area if it has been appropriately secured. ◀

For more information on loading the vehicle, refer to page 135.

Storage compartment behind the rear seat backrest

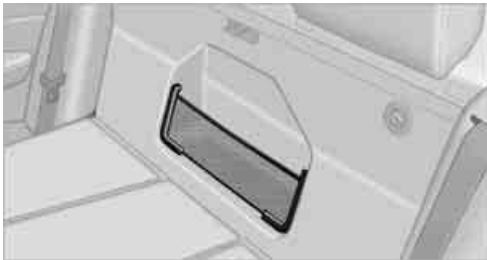

A storage compartment is located behind the rear seat backrest. To access the storage compartment: remove the insert or fold down the rear seat backrest.

 When the rear seat backrest is folded down or the insert has been removed, only transport small light objects in the storage compartment; otherwise, braking maneuvers and swerving, for example, may lead to a safety hazard due to objects flying about the passenger compartment. Only transport heavy luggage in the cargo area if it has been appropriately secured. ◀

Storage compartments inside the cargo area

Coupe

Depending on your vehicle's equipment, the following storage spaces can be found in the cargo area:

- ▷ Left storage compartment, e.g. for storing a box of cleaning tissues or up to 12 CD jackets, depending on vehicle equipment version
- ▷ Net for securing smaller objects, to be attached to the mounts on the floor panel
- ▷ Hooks for hanging up, e.g., shopping bags or tote bags
- ▷ Rubber strap on the left trim panel for securing small objects such as a folding umbrella
- ▷ Net for small objects on the right trim panel of the cargo area

Convertible

Depending on your vehicle's equipment, the following storage spaces can be found in the cargo area:

- ▷ Storage compartment on the left side of the cargo area. To open turn handle by 90°
- ▷ Net for securing smaller objects, to be attached to the mounts on the floor panel
- ▷ Rubber strap for subdividing the cargo area; can be hooked onto the lateral lashing eyes
- ▷ Stowage compartment under the floor panel

Folding up the floor panel

 Do not exceed the maximum permissible load of 55 lbs./25 kg for the storage compartment under the floor panel; otherwise, damage may result. ◀

Coupe

Press the floor panel up and secure it with the catch.

Convertible

To lift, grab hold of the floor panel at the opening at the rear of the panel.

Lashing eyes

You will find lashing eyelets in the cargo area for securing luggage items with nets or tensioning straps, refer to page 137.

Coupe: ski bag

The ski bag is designed for safe, clean transport of up to 4 pairs of standard skis or up to 2 snowboards.

With the ski bag you can stow skis with a length of up to 6.9 ft 10 in/2.10 m. When skis of 6.9 ft 10 in/2.10 m length are loaded, the overall capacity of the ski bag is reduced due to its tapered design.

Loading

1. Fold down the center armrest.
2. Press the button, reach into the recess and fold down the cover.



3. Open the Velcro fastener, spread the ski bag between the front seats and insert the skis or snowboards.

4. Clip the hooks of the ski bag retaining strap into the eyelet.



Only place clean skis in the ski bag. Wrap sharp edges to prevent damage.

Securing cargo

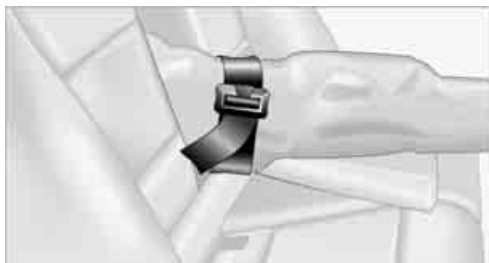

After loading, secure the ski bag and its contents. Tighten the retaining strap on the tensioning buckle for this purpose.

 Secure the ski bag in the manner described; otherwise, it could endanger the car's occupants, e.g. in case of heavy braking or sudden swerving. ◀

To store the ski bag, perform the steps described for loading in reverse order.

Removing the ski bag

The ski bag can be completely removed, e.g. for faster drying or to allow you to use other inserts.

1. Fold down the center panel in the rear seat backrest.
2. Pull the handle, arrow 1.

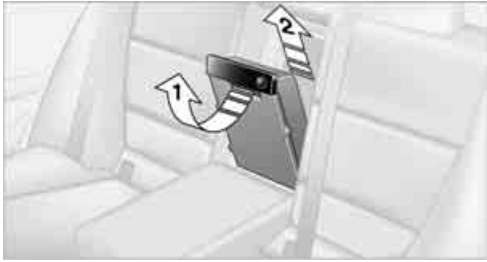

3. Pull out the insert, arrow 2.

 For more information on the various inserts available, contact your BMW center. ◀

Convertible: through-loading opening with integrated transport bag

The transport bag is designed for safe, clean transport of up to 4 pairs of standard skis or up to 2 snowboards.

When the rear seat backrest is folded up, you can remove the insert and use the transport bag with the regular through-loading opening. To transport larger objects, you can fold down the rear seat backrest to create an expanded through-loading opening.

With the transport bag you can stow skis with a length of up to 6.2 ft/1.90 m. When skis of 6.2 ft/1.90 m length are loaded, the overall capacity of the transport bag is reduced due to its tapered design.

Loading

1. For loading using the regular through-loading opening:
Press the button down and remove the insert from the front.
For loading with the through-loading opening expanded:

Fold down the rear seat backrest, refer to page 124.

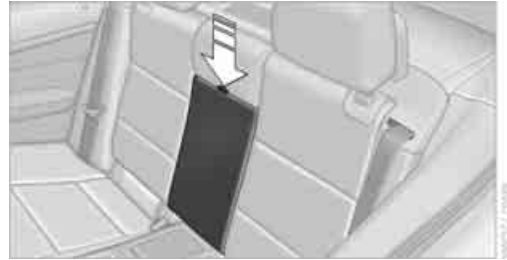

2. Front cover: press the two recesses together and fold the cover down until it engages.

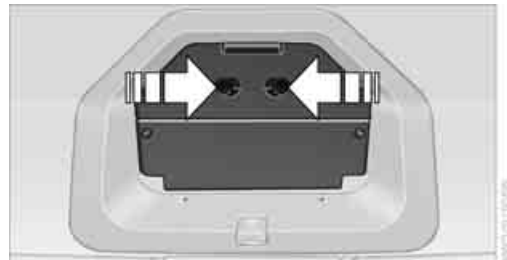

3. In the cargo area: press the two recesses together and fold down the cover.

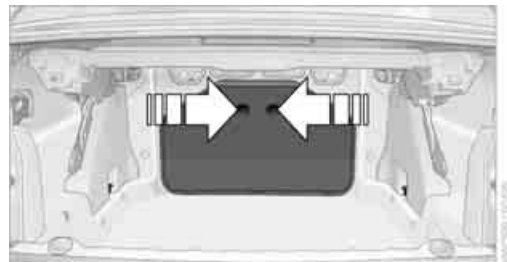

4. Undo the Velcro fastener and spread out the transport bag between the front seats.

5. Insert the latch plate of the retaining strap into the belt buckle under the transport bag.



6. Load the transport bag. The zipper eases access to the stored items.

Only place clean skis in the transport bag. Wrap sharp edges to prevent damage.

You can use the snaps to shorten the transport bag if you do not need its full length.

Securing cargo



After loading, secure the transport bag and its contents. Tighten the retaining strap on the tensioning buckle for this purpose.

 Secure the transport bag in the manner described; otherwise, it could endanger the car's occupants, e.g. in case of heavy braking or sudden swerving. ◀

To store the transport bag, perform the steps described for loading in reverse order.

Removing the front cover

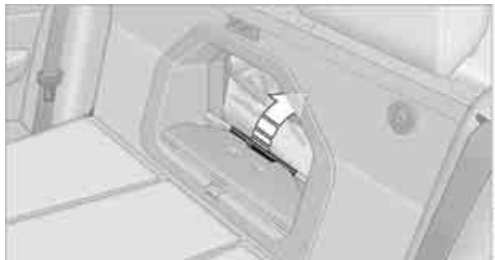

You can remove the front cover to use the full height of the through-loading opening. With the cover folded down, pull the handle, see arrow, and remove the cover toward the front. To replace, insert the cover at an angle from above and let it snap it into place.



Driving tips

This section provides you with information useful in dealing with specific driving and operating conditions.

Things to remember when driving

Vehicle equipment

In this chapter, all production, country, and optional equipment that is offered in the model range is described. As a result, some equipment described may not be available in a particular vehicle, for example due to the options or national-market version selected. This also applies to safety related functions and systems.

Break-in period

Moving parts need breaking-in time to adjust to each other. Please follow the instructions below in order to achieve the optimal service life and economy of operation for your vehicle.

Engine and differential

Always obey all official speed limits.

Up to 1,200 miles/2,000 km

Drive at varying engine and road speeds, but do not exceed an engine speed of 4,500 rpm or a road speed of 100 mph/160 km/h.

Avoid full-throttle operation and use of the transmission's kickdown mode.

After driving 1,200 miles/2,000 km

Engine and vehicle speeds can be gradually increased.

Tires

Due to technical factors associated with their manufacture, tires do not achieve their full traction potential until after an initial break-in period. Therefore, drive cautiously during the first 200 miles/300 km.

Brake system

Brakes require an initial break-in period of approx. 300 miles/500 km to achieve optimized contact and wear patterns between brake pads and rotors. Drive cautiously during this break-in period.

Clutch

The function of the clutch reaches its optimal level only after a distance driven of approx. 500 km. During this break-in period, engage the clutch gently.

Following part replacement

The same break-in procedures should be observed if any of the components mentioned above have to be renewed in the course of the vehicle's operating life.

Saving fuel

The fuel consumption of your vehicle depends on several factors. You can lower fuel consumption and the environmental impact by taking certain measures, adjusting your driving style and having the vehicle serviced regularly.

Remove any unneeded cargo

Additional weight increases fuel consumption.

Remove any mounted parts after you have finished using them

Remove unneeded additional mirrors, the roof rack and the rear luggage rack after use. Mounted parts affect the vehicle's aerodynamics and increase fuel consumption.

Close the windows and glass roof

An open glass roof or window causes higher air resistance and thus increases fuel consumption.

Check tire inflation pressure regularly

Check the tire inflation pressure at least twice a month and before embarking on a long journey, and correct it if necessary.

Low tire inflation pressure causes higher rolling resistance and thus increases fuel consumption and tire wear.

Set off immediately

Do not let the engine warm up while the car is still standing, but set off immediately at moderate engine speed. This is the fastest way for the cold engine to reach its operating temperature.

Drive defensively

Avoid unnecessary acceleration and braking maneuvers. To do so, keep an adequate distance between you and the vehicle in front of you. A defensive and smooth driving style keeps fuel consumption down.

Avoid high engine speeds

Only use first gear when setting off. In second and higher gears, accelerate without hesitation or pauses. When accelerating, shift up before reaching high engine speeds.

When you reach the desired speed, shift into the highest applicable gear and drive with the engine speed as low as possible and at a constant speed.

As a rule: driving at low engine speeds lowers fuel consumption and reduces wear.

Coasting

When approaching a red light, take your foot off the accelerator and coast to a stop in the highest applicable gear.

On a downhill slope, take your foot off the accelerator and coast in a suitable gear.

The fuel supply is interrupted when coasting.

Switch off the engine during lengthy stops

Switch off the engine when stopping for lengthy periods, e.g. at traffic lights, railroad crossings or in traffic congestions. You achieve fuel savings even if standing time is as short as approx. 4 seconds.

Switch off functions you do not need at the moment

Functions such as the air conditioner, seat heating or rear window defroster draw large amounts of power and consume additional fuel. Especially in city traffic and in stop-and-go driving they have a considerable impact. Therefore, switch these functions off when they are not really needed.

Have the vehicle serviced

Have the vehicle serviced regularly to achieve good economy and a long vehicle life. BMW recommends having the vehicle serviced at your BMW center. Also note the BMW service system, refer to page 202.

General driving notes

Close the trunk lid



Only drive with the trunk closed. Failure to do so may endanger passengers or other road users or may damage the vehicle in the event of an accident or a braking and evasive maneuver. In addition, exhaust gas may flow into the passenger compartment. ◀

If special circumstances make it absolutely necessary to drive with the trunk open:

1. Close all windows and the glass roof.
2. Greatly increase the air volume of the air conditioner or automatic climate control system, refer to page 110 or 113.
3. Drive cautiously.

Hot exhaust system

 In all vehicles, extremely high temperatures are generated in the exhaust system. Do not remove the heat shields installed adjacent to various sections of the exhaust system, and never apply undercoating to them. When driving, standing at idle and while parking, take care to avoid possible contact between the hot exhaust system and any highly flammable materials such as hay, leaves, grass, etc. Such contact could lead to a fire, with the risk of serious personal injuries and property damage. Do not touch hot exhaust tail pipes. Otherwise, there is a risk of burns. ◀

Mobile phones in the vehicle

 It is not advisable to use wireless devices such as mobile phones inside the vehicle without a direct connection to an external aerial. Otherwise, it is not possible to exclude the possibility of a reciprocal interference occurring between the vehicle electronics and the wireless device. Otherwise, there is no assurance that the radiation generated by the radio transmission will be conveyed out of the passenger compartment. ◀

Hydroplaning

 When driving on wet or slushy roads, reduce road speed. If you do not, a wedge of water can form between tires and road surface. This situation, known as hydroplaning, means that the tire can completely lose contact with the road surface, so that neither the car can be steered nor the brake be properly applied. ◀
The risk of hydroplaning increases with declining tread depth on the tires, refer also to Minimum tread depth on page 194.

Driving through water

 Drive through water on the road only if it is not deeper than 1 ft/30 cm, and then only at walking speed at the most. Otherwise, the vehicle's engine, the electrical systems and the transmission may be damaged. ◀

Use the parking brake on inclines

 On inclines, do not hold the vehicle for a lengthy period using the clutch; use the parking brake instead. Otherwise, greater clutch wear will result. ◀

For more information about the drive-off assistant, refer to page 93.

Braking safely

Your BMW is equipped with ABS as a standard feature. Applying the brakes fully is the most effective way of braking in situations in which this is necessary. Since the vehicle maintains steering responsiveness, you can still avoid possible obstacles with a minimum of steering effort.

Pulsation of the brake pedal, combined with sounds from the hydraulic circuits, indicate that ABS is in its active mode.

Objects in the movement range of the pedals

 Keep floor mats, carpet, and other objects out of the movement range of the pedals; otherwise, they may inhibit the function of the pedals during driving.

Do not place additional floor mats onto an existing one or onto other objects.

Only use floor mats that have been approved for the vehicle and can be appropriately fastened. Make sure that the floor mats are securely fastened again after they have been removed, e.g. for cleaning. ◀

Driving in wet conditions

When roads are wet or there is heavy rain, briefly exert gentle pressure on the brake pedal every few miles. Monitor traffic conditions to ensure that this maneuver does not endanger other road users. The heat generated in this process helps dry the pads and rotors to ensure that full braking efficiency will then be available when you need it.

Hills

 To prevent overheating and the resulting reduced efficiency of the brake system, drive long or steep downhill gradients in the gear in which the least braking is required. Even light but consistent brake pressure can lead to high temperatures, brake wear and possibly even brake failure. ◀

You can increase the engine's braking effect by shifting down, all the way to first gear if necessary. This strategy helps you avoid placing excessive loads on the brake system. Downshifting in manual mode of the automatic transmission, refer to page 61.

 Sport automatic transmission with double clutch: never drive with the transmission in neutral or with the engine switched off; otherwise, there will be no engine braking action and no power assistance to the brakes and steering. Manual transmission: never drive with the clutch held down, with the transmission in neutral or with the engine switched off; otherwise, there will be no engine braking action and no power assistance to the brakes and steering. Never allow floor mats, carpets or any other objects to protrude into the area around the pedals; otherwise, pedal function could be impaired. ◀

Corrosion on brake rotors

When the vehicle is driven only occasionally, during extended periods when the vehicle is not used at all, and in operating conditions where brake applications are less frequent, there is an increased tendency for corrosion to form on rotors, while contaminants accumulate on the brake pads. This occurs because the minimum pressure which must be exerted by the pads during brake applications to clean the rotors is not reached.

Should corrosion form on the brake rotors, the brakes will tend to respond with a pulsating effect that even extended application will fail to cure.

When the vehicle is parked

Condensation forms while the automatic climate control is in operation, and then exits under the vehicle. Traces of condensed water under the vehicle are therefore normal.

Cargo loading

 To avoid loading the tires beyond their approved carrying capacity, never overload the vehicle. Overloading can lead to overheating and increases the rate at which damage develops inside the tires. In some situations, this can result in sudden loss of tire pressure. ◀

 Make sure that no liquids are spilled or leak from their containers in the cargo area, as this could result in damage to the vehicle. ◀

Determining loading limit



1. Locate the following statement on your vehicle's placard:

 The combined weight of occupants and cargo should never exceed XXX kg or YYY lbs. Otherwise, damage to the vehicle and unstable driving conditions may result. ◀
2. Determine the combined weight of the driver and passengers that will be riding in your vehicle.
3. Subtract the combined weight of the driver and passengers from XXX kilograms or YYY pounds.

4. The resulting figure equals the available amount of cargo and luggage load capacity. For example, if the YYY amount equals 1,400 lbs. and there will be five 150-lbs. passengers in your vehicle, the amount of available cargo and luggage load capacity is 650 lbs.:
1,400 lbs. minus 750 lbs. = 650 lbs.
5. Determine the combined weight of luggage and cargo being loaded on the vehicle. That weight may not safely exceed the available cargo and luggage load capacity calculated in step 4.
6. If your vehicle will be towing a trailer, part of the load from your trailer will be transferred to your vehicle. Consult the manual for transporting a trailer to determine how this may reduce the available cargo and luggage load capacity of your vehicle.

Load

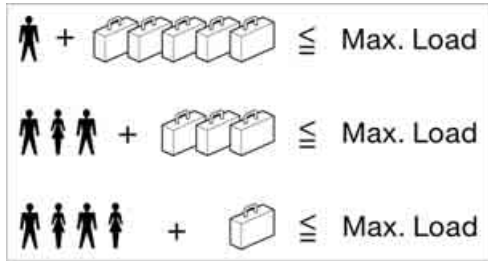

The permissible load is the total of the weight of occupants and cargo/luggage. The greater the weight of the occupants, the less cargo/luggage can be transported.

Stowing cargo

- ▷ Position heavy objects as low and as far forward as possible, ideally directly behind the respective seat backrests.
- ▷ Cover sharp edges and corners.
- ▷ For very heavy cargo when the rear seat is not occupied, secure each safety belt in the opposite buckle.

Coupe

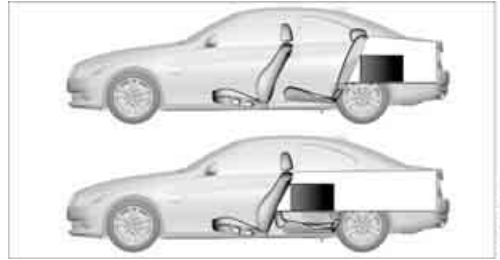

Convertible

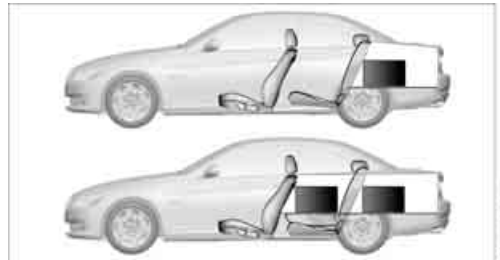

Securing cargo

Coupe

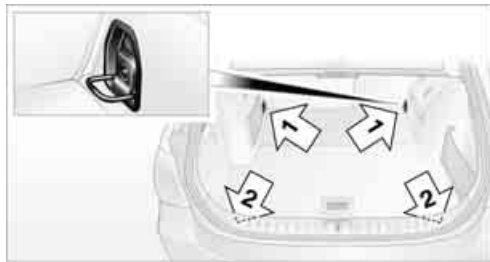

Convertible

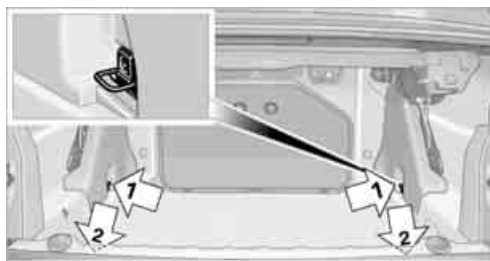

- ▶ Secure smaller and lighter items using retaining straps, a cargo area net, or draw straps.
- ▶ Heavy-duty cargo straps for securing larger and heavier objects are available at your BMW center. Four lashing eyes are provided for attaching the cargo straps. Two are located on the side walls of the cargo area **1**, two additional ones are located on the inside wall of the cargo area **2**. Please note the information supplied with the cargo straps.

! Convertible: before opening the hardtop, fold down the cargo area partition. Make sure the cargo area is loaded correctly; otherwise parts of the hardtop can be damaged, refer to page 124. ◀

! Always position and secure the cargo as described above, so that it cannot endanger the car's occupants, for example if sudden braking or swerving is necessary.

Never exceed either the approved gross vehicle weight or either of the approved axle loads, refer to page 237; otherwise, excessive loads can pose a safety hazard and may also place you in violation of traffic safety laws.

Heavy or hard objects should not be carried loose inside the car, since they could be thrown around, for example as a result of heavy braking, sudden swerves, etc., and endanger the occupants.

Only attach the cargo straps using the lashing eyes shown in the illustration. Do not secure cargo with the anchors for tether straps, refer to page 55; otherwise, these could be damaged. ◀

Coupe: roof-mounted luggage rack

A special rack system is available as an option for your BMW. Comply with the directions given in the installation instructions.

Mounting points

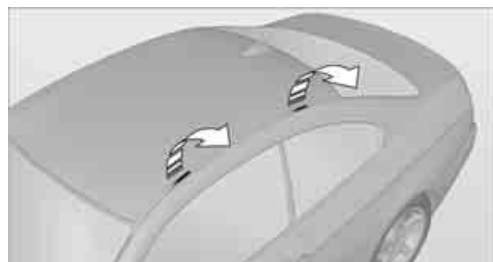

The mounting points are located in the roof.

Loading roof-mounted luggage rack

Because roof racks raise the vehicle's center of gravity when loaded, they have a major effect on vehicle handling and steering response.

You should therefore always remember not to exceed the approved roof load capacity, the approved gross vehicle weight or the axle loads when loading the rack.

You can find the applicable data under Weights on page 237.

The roof load must be distributed uniformly and should not be too large in area. Heavy items should always be placed at the bottom. Be sure that adequate clearance is maintained for tilting the glass roof, and that objects do not project into the opening path of the trunk lid.

Fasten roof-mounted cargo correctly and securely to prevent it from shifting or falling off during the trip.

Drive smoothly. Avoid sudden acceleration and braking maneuvers. Take corners gently.



Entertainment

Operation of the radio, CD equipment and external audio devices as well as their tone settings are described in this chapter.

BMW Professional radio

Vehicle equipment

In this chapter, all production, country, and optional equipment that is offered in the model range is described. Equipment is also described that is not available because of, for example, selected options or country version. This also applies to safety related functions and systems.

Switching radio on/off



Press the knob on the left. The radio selects the last set audio source: Radio, HD Radio, Satellite radio, CD, CD changer, external audio device, or USB audio interface.

Listening to the radio when the ignition is switched off

When radio readiness or the ignition is switched off, the radio functions are available for approx. 20 minutes. To do so, switch the radio on again.

 To spare the battery, ensure that the radio is switched off when leaving the vehicle. ◀

Adjusting volume



Turn the knob on the left. The setting is stored for the remote control in use.





 The audio sources are automatically muted when you make a phone call using the hands-free system. ◀

Setting the volume for the PDC and gong

You can raise or lower the audio signals for the PDC or gong with respect to the volume of the audio sources.



The audio signals have a set minimum and maximum volume, below which they can not fall and above which they can not go.

 Set the audio source to a high volume to be able to better set the volume of the audio signals. ◀

-  Press the button.
-  Press the button if necessary.
-  or  press the button.
- Set the desired volume and press the knob on the right.

Setting the speed-dependent volume



The speed-dependent volume controls automatically increases the volume as the speed of the vehicle increases. You can set different levels for increasing the volume.

1.  Press the button.
2.  Press the button if necessary.
3.  Press the button.
4. Set the desired volume and press the knob on the right.

Setting the volume for external audio devices

You can use the AUX-IN port in the center console to connect an external audio device such as an MP3 player and play audio recordings over the vehicle speakers.

The volume of the external audio device can be adjusted to the radio.

1.  Press the button.
2.  Press the button.
3.  Press the button.
4. Set the desired volume and press the knob on the right.

Setting tone controls

You can select among the following settings:

- ▷ Bass: bass adjustment
- ▷ Treble: treble adjustment
- ▷ Balance: left/right volume distribution
- ▷ Fader: front/rear volume distribution
- ▷ "ROOM"
- ▷ "LOGIC7"
- ▷ Equalizer

The tone settings are set for all audio sources at once.

Setting the bass, treble and balance



1.  Press the button.
2. Highlight the desired tone setting and press the knob on the right.
3. Select the desired volume and press the knob on the right.

Switching on the surround sound function

You can select from among the following sound patterns:

- ▷ "ROOM"
- ▷ "LOGIC7"

To select a sound pattern:



1.  Press the button.
2.  Press the button.
3. Press the desired sound pattern button, for example:



Equalizer



1.  Press the button.
2. Press the desired frequency band.
3. Adjust the settings and press the knob on the right.

To reset the settings:

1.  Press the button.
2. Turn the knob on the right.
3.  Press the button.
4.  Press the button.

Resetting tone settings

The tone settings are reset to the middle values.

1.  Press the button.
2.  Press the button.

Time

When the ignition or radio readiness is switched off, you can display the time for a few seconds.

Displaying the time

 Press the button.



Setting the time, date and time format

You can set the time, date, and time format, refer to page 86.

Radio

Your radio is designed for receiving FM and AM signals.

Listening to the radio

1. Switch on the radio, refer to page 142.
2.  Press the button if necessary.
3.  Press the button.
4.  Press the corresponding button as often as necessary until the desired wavelength band is selected.
 - ▷ AM: AM and AMA
 - ▷ FM: FM1/FM2 and FMA

Selecting a station

The setting is stored for the remote control in use.

Next station

 Press the button.

The next available station is selected.

Selecting stations by changing the frequency

1.  Press the button.
2. Press the respective function button to enter the desired frequency.

Or, by using the knob on the right:

1.  Press the button.
2. Turn the knob on the right until the desired frequency is reached.

Automatically updating strongest stations

Radio stations are stored in order of their signal strength in the memory levels FMA and AMA. If the AUTOSTORE function is not used, then six stations can be manually stored in each of the memory levels FMA and AMA.

 Press and hold the relevant button until the following display appears.

"AUTOSTORE"

It may take several seconds before the stations are stored and you can listen to one of them.

Sampling and selecting radio stations

 Press the button. Samples are played of all the stations in reception range.

To interrupt the function and select a station:

 Press the button.

Storing and recalling stations



Memory presets

Your radio can store 30 stations:



- ▷ FM1, FM2: six stations each.
- ▷ AM: six stations each of your choice

- ▷ FMA/AMA: the six stations with the strongest reception are automatically stored or six stations can be manually stored.

Storing stations

1.  Press the corresponding button as often as necessary until the desired frequency range is selected
2. Select station.
3.  Press and hold the desired button until the station starts to play again after a brief interruption.
The memory level and the selected button are shown on the display.

Recalling stored stations

1.  Press the corresponding button as often as necessary until the desired wave-length band is selected.
2.  Press the desired button.

Using the knob on the right:



Turn the knob on the right until the desired station is reached.

RDS – Radio Data System

RDS uses the FM waveband to broadcast additional information, for example the station names or possibly text messages. When a station has several frequencies, the radio will automatically switch to the frequency with the best reception quality.



Over RDS, some stations transmit the type of the received program, PTY. At the option of the station, this can be shown briefly on the display, e.g., messages, NEWS. Using PTY, warnings regarding catastrophies can also be displayed, e.g., "ALARM". The warning is then played over the speakers.

Switching RDS on/off

1.  Press the button.
2.  Press the button.

When RDS is switched off, the PTY function is also switched off.

Switching program type display on/off

1.  Press the button.
2.  Press the button.





HD Radio™ reception

Many radio stations transmit analog and digital signals.

License conditions

HD Radio™ technology is manufactured under U.S. and Foreign Patents licensed from iBiquity Digital Corp. HD Radio™ and the HD and HD Radio logos are proprietary trademarks of iBiquity Digital Corp.

Activating/deactivating digital radio reception

1.  Press the button.
2.  Press the button.
3.  Press the button.
4.  Press the button.



"HD": a station is received digitally.

"(HD)": a station is broadcasting digital signals; digital radio reception is, however, switched off.

In areas in which the station is not continuously received in digital mode, playback switches between analog and digital reception. In this case, switch off digital radio reception.

Selecting programs from a digital station

Some stations broadcast several programs. To select one of these programs:

1.  Press the button repeatedly until the desired digital station is displayed. If a station broadcasts several programs, then, e.g., "HD1" is displayed.
2.  Press the button.
3. Select the desired program. Up to eight programs per station can be selected, "HD1" to "HD8".

Displaying additional information

For digital stations, additional information about the current track is displayed, e.g., the name of the artist.

1.  Press the button. The information is displayed.

Operation indicators

- ▷ "Acquiring": a search for digital stations is being conducted.
- ▷ "No signal": there are no digital stations within range.

Satellite radio

You can receive more than 100 different channels of high audio quality. The channels are offered in fixed packages and have to be activated.

-  You may experience signal drops and muting events related to this new technology. ◀

Activating or deactivating channels



1.  Press the button.
2.  Press the button.

3.  Press the button.
4. Select the desired category. The channels are displayed.
 - ✓ This symbol indicates the current channel.



Activating

1. Turn the knob on the right to select a channel that is not yet activated.
2. Press the knob on the right to confirm a channel. A phone number and the electronic serial number, ESN, are displayed. When activating, the electronic serial number is required.
3. To activate the channels: Dial the phone number.

Deactivating

1.  Press the button.
2.  Press the button.
3.  Press the button for a longer period. A phone number and the electronic serial number, ESN, are displayed. For deactivating, the electronic serial number is required.
4. To deactivate channels: Dial the phone number.



Selecting and storing a channel

1.  Press the button.
2.  Press the button.
3.  Press the button.
4. Select the desired category.
5. Select desired channel.

To display all the channels:

1.  Press the button.

To store a channel:

1.  Press the button.
2.  Press the button as often as necessary until the desired memory level, SAT 1 or SAT 2, is reached.
3.  Press and hold the desired button until the channel starts to play again after a brief interruption.

Changing to the current channel

1.  Press the button.

Additional information

The name of the channel and additional information about the current track is displayed, e.g., the name of the artist.

1. Select the desired channel.
2.  Press the button.

Changing channels using buttons

 Press the button for the corresponding direction. The next activated channel is recalled.

Search function

1.  Press and hold the button for the corresponding direction. The activated channels are shown, one after another, on the display.
2. Release the button to select the displayed channel.

Notes

When there is a signal blockage or the transmission is suspended momentarily for more than 4 seconds, a message appears on the Control Display.

 Service may be interrupted or unavailable for specific reasons such as environmental or topographic conditions and others that Satellite Radio cannot directly control. Signals may not be available under tunnels, in parking garages, next to tall buildings, nearby trees with dense foliage, nearby mountains or other possible strong sources of radio interference. Service should resume normally after the source of signal unavailability has been cleared. ◀



CD player and CD changer

Starting the CD player

It may take a moment for the CD player to start.



1. Switch on the radio, refer to page 142.
2. Insert the CD with the printed side up into the CD slot.

If there is already a CD in the CD slot:

1. Switch on the radio, if necessary.
2.  Press the button.
3.  Press the button.

Starting CD changer

It may take a moment for the CD changer to start.

1. Switch on the radio, refer to page 142.
2. Fill the CD magazine and insert it, refer to page 149.
3.  Press the button.
4.  Press the button.

Selecting a CD

Press the button for the desired CD number.

The corresponding CD number will appear on the display. At the end of the last track, the next CD is selected and played.

Changing the music track

Skipping tracks

 Press the button as often as necessary until the desired track is played.

Using the knob on the right:

Turn the knob on the right until the desired track is played.

Fast forward/reverse

1.  Press and hold the button. Tracks can be heard but are distorted.
2. To cancel the fast forward/reverse, release the button.

Random order

 Press the button.

To terminate the random generator:

 Press the button.

Sampling and selecting tracks

 Press the button. Samples of all of the tracks are briefly played one after another.



To interrupt the function and select a track:

 Press the button.

Compressed audio files

The CD player and CD changer can also play CDs with compressed audio data: MP3 and WMA.

Selecting a track

1.  Press the button.
2. Use the knob on the right to select the desired directory.
 - ▷  : press the knob on the right to open a directory.
 - ▷  : press the knob on the right to close a directory.
3. Select additional directories if desired.
4. Highlight the desired track and press the knob on the right.



You can browse through the directories during playback.

To change to the current track:

 Press the button.

Track display

If information about the current track has been stored, it can be displayed.

1.  Press the button.
2.  Press the button.

Ejecting the CD out of the CD player

 Press the button.

The CD is partially ejected from the CD slot.

Installation location of CD changer

At the rear left of the cargo area.

Coupe



Convertible

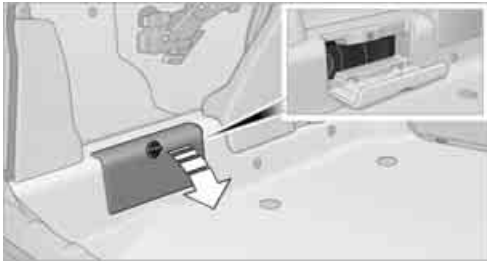

Removing/inserting CD magazine

Removing CD magazine

To insert or remove CDs from the CD magazine, you must first remove it from the CD changer.

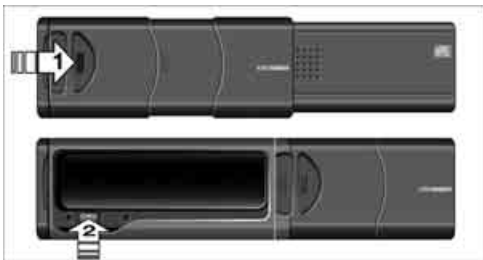

1. Push the cover to one side, arrow 1.
2. Press the button, arrow 2.

The CD magazine will be ejected.

Push the magazine back in after at least 2 seconds have passed so that the inserted CDs can be read in again.

Inserting/removing CDs from the CD magazine

When loading CDs into or removing them from the CD magazine, always hold them at their edges and do not touch the reflective side of the CD.

- ▶ Inserting CDs:
Pull out the desired compartment and insert the CD with the printed side up.



- ▶ Removing CDs:
Pull out the desired compartment and take out the CD.

Inserting the CD magazine

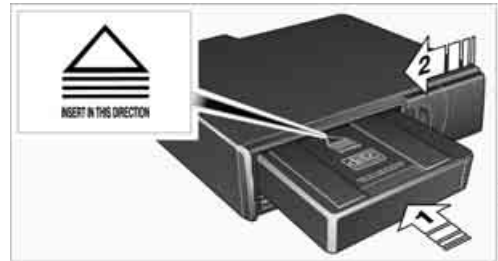

1. Insert the CD magazine all the way in the direction of arrow 1.
2. Close the cover, arrow 2.

The CD changer automatically reads in the loaded CDs and is then ready for operation.

Operation indicators

CD player

- ▷ "Insert CD"
The CD slot is empty.
- ▷ "Error CD"
The CD can not be read or is defective.
- ▷ "Temp. CD"
The operating temperature is too high.

CD changer

- ▷ "Insert CD"
The CD has been inserted incorrectly or the magazine is empty.
- ▷ "Insert MAG"
No magazine is inserted.
- ▷ "Load MAG"
The CD contents are currently being read in.
- ▷ "Temp. CDC"
The operating temperature is too high.

Notes

 BMW CD players and CD changers are Class 1 laser products. Do not operate if the cover is damaged; otherwise, serious eye injury may result.

Do not use CDs with after-market labels; otherwise, the labels can loosen as a result of the heat generated during playback and possibly cause irreparable damage to the system.

Only use round CDs with a standard diameter of 4.7 in/12 cm and do not play CDs with adapters, e.g. single CDs; otherwise, the CDs or adapters may jam and it may not be possible to eject them.

Do not use a combined CD/DVD, e.g. DVD^{Plus}; otherwise, the CD/DVD can jam and will no longer eject. ◀

General malfunctions

BMW CD players and CD changers are optimized for operation in the vehicle. They may be

more sensitive to defective CDs than players for stationary use.

If a CD can not be played, first check if the CD is properly inserted.

Humidity

If there is high humidity, the CD or the focusing lens for the laser beam may fog up, making it temporarily impossible to play the CD.

Malfunctions with individual CDs

If there are malfunctions with individual CDs, then they may be due to the following causes.

CDs that you burned yourself

Potential problems with home-burned CDs are, for example, inconsistent data generation and burning processes, as well as low quality or excessive aging of the blanks that are used.

Only write on the upper surface of CDs with a writing instrument that is suitable for the purpose.

Damaged CDs

Avoid leaving fingerprints, as well as dust, scratches or moisture on the CDs/DVDs. Store CDs in sleeves.

Do not expose CDs to a temperature greater than 50 °C/122 °F, elevated humidity, or direct sunlight.

CDs with copy protection

CDs are often provided with copy protection from the manufacturer. This can result in CDs not playing or playing back in only a limited fashion.

Care

If necessary, clean the reflecting side of the CD with a commercially available cleaning cloth by wiping in a straight line from the center outwards.

AUX-IN port

Overview

- ▷ It is possible to connect audio devices, e.g. MP3 players. Sound is output over the vehicle speakers.
- ▷ Recommended settings: mid-level tone and volume settings on the audio device. Tone may depend on the quality of the audio files.



Connecting

Lift up the center armrest.



The AUX-In connection is in the center armrest. Connect the headphone connection or line-out connection of the device to the AUX-IN port.

Playback

1. Connect the audio device, switch it on, and using the audio device, select a track.
2.  Press the button.
3.  Press the button.

Volume

The volume of the sound output depends on the audio device. If this volume differs markedly from the volume of the other audio sources, it is advisable to adjust the volumes.

Adjusting volume

1.  Press the button.
2.  Press the button.

3.  Press the button.
4. Select the desired volume and press the knob on the right.

USB audio interface

Overview

It is possible to connect external audio devices. Sound is output over the vehicle speakers.

Options for connecting external devices

- ▷ Connection via USB audio interface: Apple iPod/iPhone, USB devices, e.g. MP3 player, USB flash drive, or mobile phones that are supported by the USB audio interface.
- ▷ Connection via the snap-in adapter, when equipped with extended connectivity of the music player in the mobile phone: Apple iPhone or mobile phones. Playback may only be possible when no device is connected to the AUX-IN port.

Because of the large number of audio devices on the market, there is no way to ensure that every audio device can be properly operated via the vehicle.

Ask your BMW center for suitable audio devices/mobile phones.

Audio files

Playback of standard audio files is possible:

- ▷ MP3
- ▷ WMA
- ▷ WAV (PCM)
- ▷ AAC, M4A
- ▷ Playback lists: M3U, WPL, PLS

File systems

Popular file systems for USB devices are supported. The format FAT 32 is recommended.

Connecting



- 1 Connection for audio playback:
TRS connector 1/8"/3.5 mm
- 2 USB interface

Apple iPod/iPhone

Use the special cable adapter for Apple iPods/iPhones to produce the connection. You can obtain further information from your BMW center or on the Internet: www.bmw.com

To play audio tracks over the vehicle's speaker system, connect the iPod/iPhone to ports **1** and **2**.

The iPod/iPhone's menu structure is supported by the USB audio interface.

USB device

 To protect the USB interface and USB device from mechanical damage, connect them with the flexible adapter cable. ◀

To play audio tracks over the car's speaker system, connect the USB device to port **2**.

After initial connection

Information about all tracks, e.g. artist or music style, and the playlists of the USB device are imported into the vehicle. This process can take some time. The time required is dependent on the USB device and on the number of tracks.

Number of tracks

The data from up to four USB devices or for approx. 20,000 tracks can be stored in the vehicle. If a fifth device is connected or if more than 20,000 tracks are stored, then the data of existing tracks may be deleted.

Copy protection

 Music tracks with integrated Digital Rights Management (DRM) cannot be played. ◀

Starting audio playback

iPod

1.  Press the button.
2.  Press the button.

USB device

1.  Press the button.
2.  Press the button.

Changing music tracks

Skipping tracks

It is possible to skip tracks in the selected directory.

 Press the button as often as necessary until the desired track is played.

Using the knob on the right:
Turn the knob on the right until the desired track is played.

Fast forward/reverse

1.  Press and hold the button.
The track can be heard but is distorted.
2. To cancel the fast forward/reverse, release the button.

Random order



Press the button.

The current track is played to the end. Then the tracks in the current directory are played back in random order.

To terminate the random generator:



Press the button.

Selecting a track

Select the desired list, e.g., "LIST":



Press the button.

- If necessary, use the knob on the right to select the desired directory.
 - ▶ : press the knob on the right to open a directory.
 - ▶ : press the knob on the right to close a directory.
- Select additional directories if desired.
- Highlight the desired track and press the knob on the right.

You can browse through the directories during playback.

To change to the current track:



Press the button.

Track display

If information about the currently selected track has been stored, it can be displayed.



Press the button.

Adjusting volume

The volume of the sound output depends on the audio device. If this volume differs markedly from the volume of the other audio sources, it is advisable to adjust the volumes.

1.

Press the button.

- Turn the knob on the right until the desired volume is set and then press the knob.

Displaying the file structure of the USB device

The entire file structure of the USB device can be displayed, for example directories without music files.



Press the button.

Notes

Do not expose the audio device to extreme environmental conditions, e.g. very high temperatures, refer to the operating instructions of the audio device.

Depending on the configuration of the audio files, for example bit rates higher than 256 Kbit/s, it is not always possible to ensure proper playback in every case.

Information on connection

- ▶ The connected audio device is supplied with a max. power of 500 mA if supported by the device. For this reason, do not additionally connect the device to a charging socket in the vehicle; otherwise, it may not be possible to ensure proper playback.
- ▶ Do not use force when plugging the connector into the USB interface.
- ▶ Do not connect devices such as fans or lamps to the USB audio interface.
- ▶ Do not connect USB hard drives.
- ▶ Do not use the USB audio interface to recharge external devices.



Communications

This chapter describes how to use the telephone, BMW Assist and BMW TeleServices.

Telephone

Vehicle equipment

In this chapter, all production, country, and optional equipment that is offered in the model range is described. Equipment is also described that is not available because of, for example, selected options or country version. This also applies to safety related functions and systems.

Overview

Note

Your BMW is equipped with a full preparation package mobile phone or hands-free system.

The concept

Mobile phones can be connected to the vehicle through Bluetooth.

After a suitable mobile phone is paired with the vehicle once, the mobile phone can be controlled via the radio, the buttons on the steering wheel, and by voice.

Bluetooth® is a registered trademark of Bluetooth® SIG, Inc.

 Only make entries when traffic conditions permit. Do not hold the mobile phone in your hand while you are driving; use the hands-free system instead. If you do not observe this precaution, your being distracted can endanger vehicle occupants and other road users. ◀

Snap-in adapter

The snap-in adapter, refer to page 165, makes it possible to:

- ▷ Accommodate the mobile phone.
- ▷ Recharge its battery.
- ▷ Connect it to an external antenna of the vehicle.

This assures a better network connection and constant sound quality.

A mobile phone that is connected to the vehicle should not be operated via the mobile phone keypad; otherwise, malfunctions may occur.

Suitable mobile phones

For precise information about which mobile phones with a Bluetooth interface are supported by the complete mobile phone preparation package, go to www.bmwusa.com/bluetooth.

Notes

At high temperatures, the charging function of the mobile phone may be limited and some functions may no longer be carried out.

When using the mobile phone via the vehicle, follow the instructions given in the owner's manual for the mobile phone.

Controls

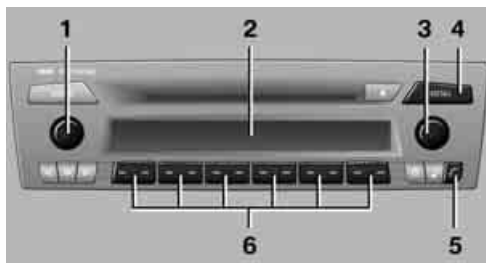

- 1 Volume control ON/OFF.
 - ▷ Press: switching radio on/off
 - ▷ Turn: adjusting volume 160
- 2 Display

- 3 Highlighting/selecting a menu item.
 - ▷ Turn: highlighting the menu item in the display or setting a value.
 - ▷ Press: selecting a highlighted menu item or storing a setting.
- 4 Open the main menu
- 5 Redialing, answering a call, starting to dial, ending a call, and switching to the phone menu.
- 6 Function buttons for selecting the menu items situated directly above them on the display.

Presentation in the Owner's Manual

"..." identifies radio display texts used to select individual functions.

Symbols on the display

Symbol	Function
✓	Function is selected
↶	Exit menu, go back one menu
◀	Show other menu items
▶	Show other menu items
◆	Scroll display, list contains more than 2 entries
📶	Reception of the mobile phone network: display depends upon signal strength.
🔊	Making a call with the hands-free system.

Pairing/unpairing mobile phone

Overview

The pairing data of four mobile phones can be stored simultaneously in the vehicle. When the engine is running or the ignition is switched on, each paired mobile phone is automatically detected as soon as it is present in the passen-

ger compartment. If a fifth mobile phone is paired, then the pairing data of one mobile phone must be deleted, refer to Mobile phone unpairing, page 159.

Requirements

- ▷ Suitable mobile phone, refer to page 156.
- ▷ The mobile phone is ready to operate.
- ▷ Bluetooth activated in vehicle, refer to page 157, and in the mobile phone.
- ▷ Depending on the mobile phone type, it may be necessary to make certain settings on the mobile phone, e.g. via the following menu items:
 - ▷ Bluetooth switched on
 - ▷ Connection not confirmed
 - ▷ Reconnection
- ▷ Depending on the mobile phone type, the power-saving mode setting, for example, may result in a paired mobile phone not being detected by the vehicle.
- ▷ A number with at least 4 and at most 16 digits has been established as the Bluetooth passkey. Only required once for pairing.
- ▷ The ignition is switched on.

Activating/deactivating Bluetooth link

Bluetooth is not permitted everywhere. Comply with all safety guidelines and regulations.

To deactivate the Bluetooth connection:

1. Switch on radio readiness or ignition.

2.  Press the button.



3.  Press the button.

4.  Press the button.

5.  Press the button.





6.  Press the button.

To reactivate the Bluetooth connection:

1.  Press the button.
2.  Press the button.

Pairing and connecting

 Only pair the mobile phone when the vehicle is stopped; otherwise, inattention may lead to endangerment of passengers or other road users. ◀

1. Switch on radio readiness or ignition.
2.  Press the button.
3.  Press the button.
4.  Press the button.
5.  Press the button.

Turn the right rotary knob to display the Bluetooth name of the vehicle on the display.

6. Additional operations must be carried out on the mobile phone, refer to the owner's manual for the mobile phone, for example look under Bluetooth device, connecting or pairing/



The Bluetooth name of the vehicle appears on the mobile phone display.

7. Select the Bluetooth name of the vehicle on the mobile phone display.

The mobile phone or the radio display will prompt you to enter the same Bluetooth passkey.

8. Enter and confirm the Bluetooth passkey using the number buttons of the mobile phone.
9.  Press the button to enter the Bluetooth passkey using the radio.
10. Using the function buttons 0-9, enter the same Bluetooth passkey that was entered into the mobile phone.

To delete the last digit:

11.  Press the button.
12.  Press the button if necessary.

If the pairing succeeded, the mobile phone will appear on the radio display.

Four mobile phones can be paired with the vehicle simultaneously.

If the pairing was not successful: what to do if..., refer to page 159.

Repeating the pairing procedure/help

If the coupling did not succeed:

1.  Press the button.
2. Repeat steps 7 through 12.

If the pairing has been repeatedly unsuccessful, please contact Customer Relations.

To display the Customer Relations phone number:

1.  Press the button.

Rotate the knob on the right to display the Customer Relations phone number and the information required for the pairing.





Following the initial pairing

- ▷ The mobile phone is detected/connected in the vehicle within a short period of time when the engine is running or the ignition is switched on.
- ▷ After identification, phone book entries are imported from the mobile phone and/or SIM card, depending on the mobile phone.
- ▷ Four devices can be paired.
- ▷ Some mobile phones may require certain settings, for example authorization or a secure connection, refer to the owner's manual for the mobile phone.





Connecting a particular mobile phone

If more than one mobile phone is detected by the vehicle, the mobile phone at the top of the list is connected. It is possible that another detected mobile phone is linked to the vehicle. A different mobile phone can be connected by selecting it.

The connected mobile phone is denoted with the following symbol in the radio display: ✓
To change the sequence of mobile phones in the list:

1. Switch on radio readiness or ignition.
2.  Press the button.
3.  Press the button.
4.  Press the button.
5. Turn the knob on the right until the display shows the mobile phone whose position in the list is to be changed.
6.  Press the button repeatedly until the desired position is reached.

Mobile phone unpairing

1. Switch on radio readiness or ignition.
2.  Press the button.
3.  Press the button.
4.  Press the button.
5. Turn the right knob to show the desired mobile phone on the radio display.
6.  Press the button.
7.  Press the button to acknowledge the message displayed.

What to do if...

For information on suitable mobile phones, refer to page 156.

The mobile phone could not be paired or connected.

- ▷ Is Bluetooth activated in the vehicle and in the mobile phone? Activate Bluetooth in the vehicle and in the mobile phone.
 - ▷ Do the Bluetooth passkeys on the mobile phone and the vehicle match? Enter the same passkey on the mobile phone and via the radio.
 - ▷ Is the passkey input taking longer than 30 seconds? Repeat the pairing procedure.
 - ▷ Are too many Bluetooth devices connected to the mobile phone? If so, delete the connections with other devices on the mobile phone.
 - ▷ Is the mobile phone in power economy mode or does it only have a small amount of battery charge remaining? Charge the mobile phone in the snap-in adapter or via a charging cable.
 - ▷ Depending on the mobile phone, it may only be possible to connect one device to the vehicle. Unpair the connected device from the vehicle and only pair and connect one device.
 - ▷ Delete connection to the mobile phone and, if necessary, to the radio and try again.
- Is the mobile phone no longer responding?
- ▷ Switch the mobile phone off and back on again. Repeat the pairing procedure.
 - ▷ Is the ambient temperature too high or too low? Do not subject your mobile phone to extreme ambient temperatures.

Phone book entries are not displayed, not all of them are displayed, or they are displayed incompletely.

- ▷ The transfer of phone book entries has not yet completed.
- ▷ In some cases, only the phone book entries of the mobile phone or the SIM card will be transferred.
- ▷ It may not be possible to display phone book entries with special characters.
- ▷ The number of phone book entries to be stored is too high.
- ▷ The data volume of the phone book entry is too great, e.g. due to additionally stored information such as notes? Reduce the data volume.

The telephone connection quality is low.

- ▷ Depending on the mobile phone, it is possible to adjust the strength of the Bluetooth signal.
- ▷ Insert the mobile phone into the snap-in adapter or place it in the vicinity of the center console.
- ▷ Adjust the volume of the microphone and speaker separately.

If you have gone through all items in the list and still cannot activate the desired function, please contact Customer Relations or your BMW center.

Operation

The following functions can be operated using the radio:

- ▷ Accepting/refusing a call
- ▷ Dialing phone numbers
- ▷ Dialing a phone number from the phone book
- ▷ Dialing a stored number, e.g., from a list of accepted calls

- ▷ In connection with the preparation for mobile phone Business: BMW Assist, refer to page 167

When the ignition is switched off and radio readiness switched on, e.g. after removal of the infrared remote control, an ongoing conversation can be continued for a maximum of 25 minutes using the hands-free system.

Adjusting volume



Turn the knob until the desired volume is reached. The setting is stored for the remote control currently in use.

The vehicle automatically adjusts the volume of the microphone on the phone and the volume of the person with whom you are talking. Depending on the mobile phone, it may be necessary to adjust the volumes. The settings can only be made during a call and must be made separately for each phone. The settings are deleted as soon as the phone is unpaired.

Receiving calls

If the number of the caller is stored in the phone book and the phone number is transmitted by the network, then the name of the contact will be displayed. Otherwise, only the phone number will be displayed.

Accepting a call

 Press the button on the steering wheel or on the radio.

Alternative:



Press the button.

Rejecting a call



Press the button.

Calling

Dialing phone numbers

1. Switch on radio readiness or ignition.
2. Press the button.
3. Press the button.
4. Press the button.
5. Enter the desired phone number using the 0-9 buttons.

To delete the last digit:



Press the button.

6. Press the button on the steering wheel or on the radio.

Alternative:

Press the knob on the right to dial the phone number.

In order for your phone number to be displayed to the person you are talking to, the display of phone numbers must be enabled by your provider.

Ending a call

Press the button on the steering wheel or on the radio.

Alternative:



Press the button.

Dialing a phone number from the phone book or from phone numbers stored in a list

Phone numbers dialed, incoming calls, and phone book entries are stored in lists when the mobile phone is connected to the vehicle via Bluetooth. If the caller is entered in the phone book, then the name of the entry is displayed

instead of the phone number.

Select the desired name from the list and establish the connection.

There are five available lists:



- ▷ "A-Z"
The entries of the phone book, the SIM card, or the mobile phone, composed of a name and phone number, are sorted alphabetically.
- ▷ "TOP8"
The Top 8 list automatically stores the eight phone numbers of the phone book that are dialed the most frequently.
- ▷ "LAST8"
The eight phone numbers dialed last are stored. The phone number dialed last appears at the top of the list.
- ▷ "CALLS"
The phone numbers of the last eight accepted calls are stored. This requires the phone number of the caller to have been transmitted.
- ▷ "MISSED"
The phone numbers of the last eight calls that were not accepted are stored. This requires the phone number of the caller to have been transmitted.

Dialing a phone number from the phone book

The A-Z list is available for phone book entries. If entries with different names, but the same phone number are transferred from the mobile phone to the vehicle, only one entry is displayed.

The displays of the phone book entries on the radio display can differ from the displays on the mobile phone display, e.g. sequence of the first and last names.

1. Switch on radio readiness or ignition.
2. Press the button.
3. Press the button.

4.  Press the button.
 The arrows indicate that additional letters can be displayed. Turn the knob on the right to display additional letters.
5. Turn the knob on the right to select the first letters of the desired entry.
6.  Press the button if so desired.
The phone number is dialed.

To display all entries:

1. Turn the knob on the right to select the first letters of the desired entry and press the knob.
2. Turn the knob on the right to select the desired entry and press the knob on the right.



The phone number is dialed.

The phone number can also be dialed using the buttons on the steering wheel or radio:



1.  Press the button.

Editing and dialing a phone number from the phone book

The phone number of an entry can be edited before a call. This change is not stored in the phone book.



1. Select an entry.
2.  Press the button.
3.  Press the button to delete a digit.
4. Enter additional digits using the 0-9 buttons.
5. Press the knob on the right to dial the phone number.

Dialing a phone number from the phone book using buttons on the steering wheel

1.  Press and hold the button to display the telephone menu.
2. Use the arrow buttons on the steering wheel to scroll through the phone book.
3.  Press and hold the button to dial the phone number.

Dialing a phone number stored in a list

To select an entry and establish a connection:

1. Switch on radio readiness or ignition.
2.  Press the button.
3.  Press the button.
4.  Press the desired button to select one of the four lists.
5. Turn the knob on the right to select an entry and press the knob to dial the phone number.

Deleting an individual entry

1. Select the desired entry from the list.
2.  Press the button.

Keypad dialing

Use the multi-frequency dialing system to access network services or to control devices, for example to remotely access an answering machine. This requires the DTMF code.

This function is available if a connection has been established and the call is being made using the hands-free system.

1.  Press the button.
2. Enter the desired code using the 0-9 buttons.

3.  If needed, press and hold the button on the right or left side to enter special characters.

Displaying call duration

To display the duration during a call:



Hands-free system

General information

Calls being conducted using the hands-free system can be continued using the mobile phone and vice versa.

From the mobile phone to the hands-free system

Calls that have been initiated from outside the Bluetooth range of the vehicle can be continued using the hands-free system if the ignition is switched on.

Depending on the mobile phone, the call is automatically switched to hands-free mode.

If the switch does not occur automatically, then follow the instructions that appear on the display of the mobile phone, also refer to the owner's manual for the mobile phone.

From hands-free system to mobile phone

Calls being conducted using the hands-free system can also be continued using the mobile phone if so desired, depending on the mobile phone.

At this point, follow the instructions that appear on the display of the mobile phone, also refer to the owner's manual for the mobile phone.

Operation by voice

The concept

The mobile phone can be operated without removing your hand from the steering wheel. In many cases, the entry process is supported by means of announcements or questions.

Symbols in the Owner's Manual

-  ›...‹ Say the specified commands word for word.
- ››...‹‹ Indicates responses of the voice activation system.

Voice commands

Activating voice activation system

1. Press the  button on the steering wheel.
2. Say the command.

Deactivating voice activation system

Press the  button on the steering wheel or

 ›Cancel‹.

Possible commands

Having possible commands read aloud

The system understands default commands that must be spoken word for word.

 ›Help‹.

Possible commands are read aloud.

Digits from zero to nine are recognized.

Each digit can be spoken individually or combined into a sequence to accelerate the entry process.

Using alternative commands

There are often a number of commands to run a function, e.g.:

 ›Dial name‹ or ›Name‹.

Important for voice commands

When issuing voice commands, make sure to:

- ▷ Pronounce the commands smoothly and at normal volume, avoiding excessive emphases and pauses.
- ▷ Keep the doors, windows and glass roof closed to prevent interference from outside noise.
- ▷ Avoid ambient noise in the vehicle while speaking.

Example: dialing phone numbers

1. Press the  button on the steering wheel.
2. ›Dial number‹

The system replies: ››Please say the number‹‹.

3. For example: ››123 456 7890‹‹
The system replies: ››123 456 7890. Continue ?‹‹
4. ›Dial‹
The system replies: ››Dialing number‹‹

Calling

Dialing phone numbers

1. ›Dial number‹.
2. Say the phone number.
3. ›Dial‹.

The connection to the desired subscriber is established.

Correcting phone number

After the last spoken sequence of digits has been repeated by the system, you can delete this sequence of digits.

1. ›Correct number‹.
The sequence of digits is deleted.

The command ›Correct number‹ can be repeated as often as you like.

Deleting phone number

1. ›Delete‹.

All digits entered up to this point are deleted.

Voice phone book

A separate voice phone book is needed for operation using voice commands. Names and phone numbers of the voice phone book are independent from the mobile phone memory or the SIM card memory of the mobile phone. In this case, phone numbers stored in the mobile phone or on the SIM card cannot be accessed by voice or stored in them by voice.

Storing the entry

An entry always consists of a name and a phone number.

1. ›Save name‹.
2. Say the name aloud.
Saying the name for the voice phone book should not take longer than approx. 2 seconds.
3. Say the phone number after being prompted to do so by the system.
4. ›Save‹.

Selecting a phone number of an entry

1. ›Dial name‹.
2. Say the name when prompted by the system.
3. Confirm request: ›Yes‹

Having entries read aloud

1. ›Read phonebook‹.
The dialog for reading phone book is opened.
2. Say ›Dial number‹ after the desired entry is read.

Redialing

To redial the phone number dialed last:

1. ›Redial‹.

Deleting an entry from the voice phone book

You can delete any entry from the voice phone book.

1. ›Delete name‹ .
2. Say the name when prompted by the system.
3. Confirm request: ›Yes‹

Deleting all entries from the voice phone book

1. ›Delete phonebook‹ .
The dialog for deleting phone book is opened.
2. Confirm request: ›Yes‹
3. Confirm request again: ›Yes‹

Adjusting volume



Turn the knob on the left during the announcement.



- ▷ The volume remains the same, even if the volume of other audio sources is changed.
- ▷ The volume is stored for the remote control currently in use.

BMW phone numbers

It is possible to store phone numbers for several BMW services without having BMW Assist activated. As soon as BMW Assist is activated, the services of BMW Assist are available, refer to page 167.

- ▷ "Road Assist": BMW Group Mobile Service, if you require assistance in the event of a breakdown.
- ▷ "Service": your BMW center, for example when you wish to schedule a service appointment.
- ▷ "Customer Relations": Customer Relations, for information about your vehicle.

Displaying phone numbers

1. Switch on radio readiness or ignition.
2.  Press the button.
3.  Press the button.
4. Turn the knob on the right until the desired phone number is displayed.

Snap-in adapter

General information

Detailed information on snap-in adapters that compatibly support mobile phone functions can be found at your BMW center.

Notes

At high temperatures, the charging function of the mobile phone may be limited and some functions may no longer be carried out.

When using the mobile phone via the vehicle, follow the instructions given in the owner's manual for the mobile phone.

Inserting/removing snap-in adapter

1. Press button **1** and remove the cover.

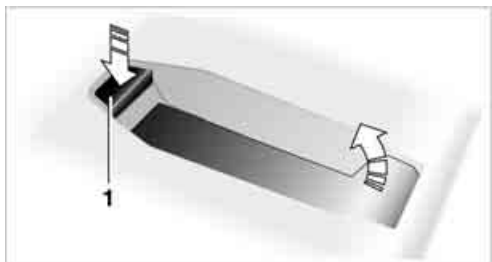

2. Insert the snap-in adapter at the front, arrow **1**, and press downward, arrow **2**, until it clicks into place.



3. To remove the snap-in adapter, press the button **1**.

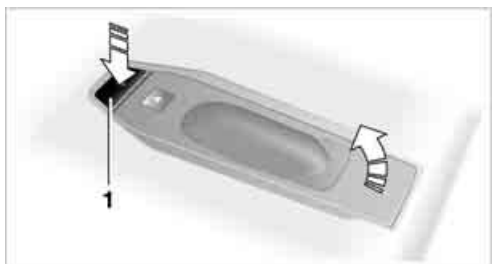

Inserting/removing mobile phone

1. Depending on the mobile phone, remove the protective cap from the mobile phone's antenna connector so that the mobile phone can engage in the snap-in adapter.
2. Push the mobile phone with the buttons facing upward toward the electrical connections and press down until it engages.

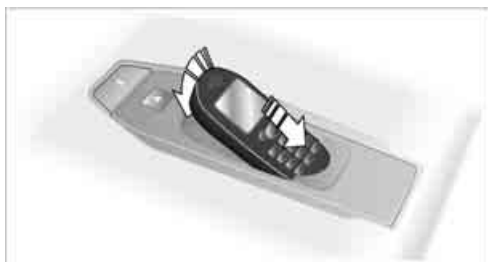

With the vehicle in radio readiness and above, the battery is charged, refer to charging symbol on the mobile phone.

To remove the mobile phone:

Press the button.

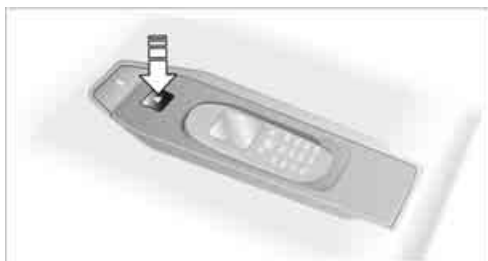

ConnectedDrive

Vehicle equipment

In this chapter, all production, country, and optional equipment that is offered in the model range is described. Equipment is also described that is not available because of, for example, selected options or country version. This also applies to safety related functions and systems.

BMW Assist

General information

BMW Assist provides a number of different services. For example, the position data of the vehicle can be transmitted to the BMW Assist Response Center when an Emergency Request is sent.

Many BMW Assist services depend on the contract individually agreed upon.

After the contract has expired, the BMW Assist system will be deactivated by the BMW Assist Response Center without you having to visit a BMW center. After the BMW Assist system has been deactivated, no BMW Assist services will be available. The BMW Assist system can be reactivated by a BMW center after a new contract has been signed.

Requirements

- ▷ The installed BMW Assist system is logged into a mobile phone network. This network must be capable of transmitting the services.
- ▷ To transmit position data, the vehicle must be able to determine its current position.
- ▷ The BMW Assist was ordered at your BMW center or the BMW Assist Response Center and the service contract was signed. The service must have been fully enabled.
- ▷ BMW Assist is activated.

Services offered

The following services are available through BMW Assist:

- ▷ **Emergency Request:**
When you press the SOS button, a connection to the BMW Assist Response Center is established. The BMW Assist Response Center then speaks with you and takes further steps to help you.
- ▷ **Automatic Emergency Request:**
Under certain conditions, a connection to the BMW Assist Response Center is established immediately after a serious accident. If possible, the BMW Assist Response Center then speaks with you and takes further steps to help you.
- ▷ **Enhanced Roadside Assistance:**
BMW Roadside Assistance can be contacted if assistance is needed in the event of a breakdown. If possible, the vehicle data and position data are transmitted during this call.
- ▷ **Customer Relations:**
connection to Customer Relations for information on all aspects of your vehicle.
- ▷ **TeleServices:**
data on your vehicle's service status or required inspections are transmitted to your BMW center, either automatically before a service due date or when you request a BMW service appointment.
- ▷ **Remote Door Unlock:**
the BMW Assist Response Center provides assistance if, for example, the remote control is not available and the vehicle needs to be opened.
- ▷ **Stolen Vehicle Recovery:**
after you report to the police that your vehicle was stolen, the BMW Assist Response Center can determine its position.

- ▷ In addition, the optional Convenience Plan offers Concierge service and information on route planning, the traffic situation and weather. Using Critical Calling, a limited number of calls can be made via the BMW Assist Response Center, for example if the mobile phone is not available or discharged. Press the SOS button to contact the BMW Assist Response Center.

BMW TeleServices

General information

TeleServices supports communication with your BMW center.

- ▷ Data on the vehicle's service requirements can be sent directly to the BMW center. In this way, the BMW center can plan its work in advance. This shortens the duration of the service appointment.
- ▷ In the event of a breakdown, data on the vehicle's condition can be sent directly to Roadside Assistance. It may be possible to correct some malfunctions immediately.
- ▷ The service varies by country.
- ▷ Connection may incur charges.
- ▷ Services may be restricted abroad.

Requirements

- ▷ Vehicle is equipped with the preparation for mobile phone Business.
- ▷ BMW Assist is activated.
If BMW Assist is not activated, then a mobile phone that is recommended by BMW for TeleServices and is configured for mobile data communication must be connected to the vehicle.
- ▷ SIM card is enabled for toll-free service phone numbers.
- ▷ Wireless reception is available.
- ▷ Ignition switched on.

Using BMW TeleServices





BMW TeleService is generally activated in the vehicle.

If TeleService is not activated, it is still possible to establish a voice contact to the BMW Group Mobile Service.

For additional uses or to deactivate the services, consult your BMW center or contact Customer Relations.

Activating or updating BMW TeleService or BMW Assist

BMW TeleService or BMW Assist must be activated before their services can be used.



1. Switch on radio readiness or ignition.
2.  Press the button.
3.  Press the button.
4.  Press the button.
5.  Press the button.
6.  Press the button.

BMW TeleService and where appropriate BMW Assist are activated and the data exchange with BMW Service begins. The activation process takes a few minutes. The respective status appears on the display.

Concierge service

The Concierge service of BMW Assist will inform you, for example, about upcoming events, filling station, or hotels and supplies you with their phone numbers and addresses. Many hotels can be booked directly through the BMW Assist Concierge service. Use of the Concierge service requires an additional activation by the BMW Assist Response Center.

Starting the Concierge service

1. Switch on radio readiness or ignition.
2.  Press the button.
3.  Press the button.
4.  Press the button.
5. Press the knob on the right to call the concierge service.

Reading message

-  The message has not been read yet.

Dialing transmitted phone number



1. Select concierge and press the knob.
2. Select phone number and press the knob.

Deleting message

1. Select message and press the knob.
2.  Press the button.

Roadside Assistance

BMW Roadside Assistance can be contacted if assistance is needed in the event of a breakdown. In a vehicle with TeleService, assistance is first offered through the TeleService Diagnosis and then if necessary, through the TeleService Help.

1. Switch on radio readiness or ignition.
2.  Press the button.
3.  Press the button.
4.  Press the button.



Vehicle data that are required for the diagnosis by the BMW TeleService are transmitted. The contact with BMW Roadside Assistance is established. BMW Roadside Assistance performs in-depth diagnosis of the vehicle.

5.  After completion of each help task by BMW Roadside Assistance, press the button.

Automatic Service Notification

The data regarding the maintenance status of your vehicle or legally mandated inspections of the vehicle are automatically transmitted prior to a service due date.



Manual Service Notification

1. Switch on radio readiness or ignition.
2.  Press the button.
3.  Press the button.
4.  Press the button.

The data relevant for the service are transmitted. The service will contact you to arrange a service appointment.



Customer Relations

Contact Customer Relations for information on all aspects of your vehicle.

1. Switch on radio readiness or ignition.
2.  Press the button.
3.  Press the button.
4.  Press the button.

My Info

With this service, text messages associated with phone numbers can be sent via the BMW Assist Internet portal and displayed in the vehicle.

1. Switch on radio readiness or ignition.
2.  Press the button.
3.  Press the button.
4.  Press the button.
The messages sent are automatically displayed.
5. To display an existing message:
Select message and press the knob.

It is possible to display a maximum of ten messages. If additional messages are received, existing messages are automatically deleted.

Reading message

- ✉ The message has not been read yet.

Dialing transmitted phone number

If you have received a message with a phone number, you can forward it to your phone and dial the phone number.





1. Select message and press the knob.
2.  Press the button.

Deleting message

1. Select message and press the knob.
2.  Press the button.





Service status

Displaying services

1. Switch on radio readiness or ignition.
2.  Press the button.
3.  Press the button.
4.  Press the button.
5.  Press the button.
6. Turn the knob on the right to display the activated services.

Displaying vehicle data

With BMW TeleService or BMW Assist activated, you can have the vehicle identification number of your vehicle displayed.

1. Switch on radio readiness or ignition.
2.  Press the button.
3.  Press the button.
4.  Press the button.
5.  Press the button.

The BMW Assist profile of the vehicle is displayed.





Mobility

This section helps you maintain your car's mobility by supplying important information on vital topics including fuels and lubricants, wheels and tires, service, maintenance and Roadside Assistance.

Refueling

Vehicle equipment

In this chapter, all production, country, and optional equipment that is offered in the model range is described. For this reason, descriptions will be given of some equipment that may not be available in a vehicle, for example due to the special options or national-market version selected. This also applies to safety related functions and systems.

General information

 Always switch off the engine before refueling; otherwise, fuel cannot be added to the tank and a message will be displayed. ◀

 Take all precautionary measures and observe all applicable regulations when handling fuel. Do not carry any spare fuel containers in your vehicle. They can develop a leak and cause an explosion or cause a fire in the event of an accident. ◀

Fuel filler flap

Opening

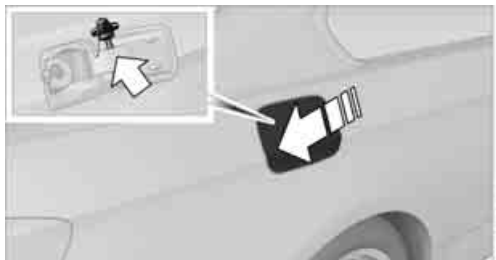

1. Open the fuel filler flap. To do so, lightly press the rear edge.

2. Turn the fuel cap counterclockwise.
3. Place the fuel cap in the bracket attached to the fuel filler flap.

Closing

Fit the cap and turn it clockwise until you clearly hear a click.

 Do not pinch the band attached to the cap; otherwise, the cap cannot be closed properly and fuel vapors can escape. ◀

Manually releasing the fuel filler flap

In the event of a malfunction, you can release the fuel filler flap manually:

Coupe



1. Remove the cover from the right-hand side-wall of the cargo area.
2. Pull the knob with the fuel pump symbol. The fuel filler flap is released.

Convertible

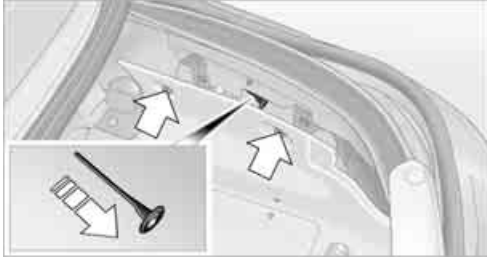

1. Loosen the right-hand cargo area trim panel by turning the screws by 90°, see arrow.
2. Slightly lift the top section of the panel. It is not necessary to remove the entire panel.
3. Pull the knob with the fuel pump symbol. The fuel filler flap is released.

Observe the following when refueling

 When handling fuels, follow the safety instructions provided at filling stations; otherwise, there is a risk of personal injury or property damage. ◀

When refueling, insert the filler nozzle completely into the filler pipe. Avoid lifting the filler nozzle while filling the tank, as that would lead to

- ▷ Premature pump shutoff
- ▷ Reduced efficiency of the fuel-vapor recovery system.

The fuel tank is full when the filler nozzle clicks off the first time.

Fuel tank capacity

Approx. 16.1 US gal/61 liters, including the reserve capacity of 2.1 US gal/8 liters.

 Refuel as soon as possible once your cruising range falls below 30 miles/50 km; otherwise, engine functions are not ensured and damage can occur. ◀

Fuel specifications

Gasoline engine: required fuel

Never use fuels labeled at the fuel pump as metal-containing.

 Do not use leaded gasoline or gasoline with metal-containing additives doing so can cause permanent damage to the catalytic converter or other components. ◀

 Do not fill the tank with E85, i.e. fuel containing 85% ethanol, nor with FlexFuel. Otherwise, the engine and fuel supply system will be damaged. ◀

Super Premium Gasoline/AKI 91

BMW recommends AKI 91.

Gasoline with lower AKI

The minimum AKI Rating is:

- ▷ 328i/xDrive: 87
- ▷ 335i, 335i/xDrive: 89.

If you use gasoline with this minimum AKI Rating, the engine may produce knocking sounds when starting at high outside temperatures. This has no effect on the engine life.

 Do not use any gasoline below the specified minimum fuel grade. Otherwise, the engine could be damaged. ◀

Use high-quality brands

Field experience has indicated significant differences in fuel quality: volatility, composition, additives, etc., among gasolines offered for sale in the United States and Canada. Fuels containing up to and including 10% ethanol or other oxygenates with up to 2.8% oxygen by weight, that is, 15% MTBE or 3% methanol plus an equivalent amount of cosolvent, will not void the applicable warranties with respect to defects in materials or workmanship.



The use of poor-quality fuels may result in drivability, starting and stalling problems especially under certain environmental conditions such as high ambient temperature and high altitude.

Should you encounter drivability problems which you suspect could be related to the fuel you are using, we recommend that you respond by switching to a recognized high-quality brand such as gasoline that is advertised as Top Tier Detergent Gasoline.

Failure to comply with these recommendations may also result in unscheduled maintenance. ◀

BMW recommends BP fuels 

Wheels and tires

Vehicle equipment

In this chapter, all production, country, and optional equipment that is offered in the model range is described. For this reason, descriptions will be given of some equipment that may not be available in a vehicle, for example due to the special options or national-market version selected. This also applies to safety related functions and systems.

Tire inflation pressures

Information for your safety

It is not merely the tires' service life, but also driving comfort and, to a great extent, driving safety that depend on the condition of the tires and the maintenance of the specified tire pressure.

 Check the tire inflation pressure regularly and correct it, if necessary: at least twice a month and before starting long trips. If you fail to observe this precaution you may be driving on tires with incorrect tire pressures, a condition that can not only compromise your vehicle's driving stability, but also lead to tire damage and the risk of an accident. Do not drive with deflated, i.e. flat tires, except when using run-flat tires. A flat tire will seriously impair your vehicle's handling and braking response. Attempts to drive on a flat tire can lead to loss of control over the vehicle. ◀

Checking pressure

Only check tire inflation pressure when the tires are cold. This means after a maximum of 1.25 miles/2 km driving or when the vehicle has been parked for at least 2 hours. When tires are warm, the tire inflation pressure is higher.

 After correcting the tire inflation pressure, reset the Tire Pressure Monitor, refer to

page 95, or reinitialize the Flat Tire Monitor, refer to page 93. ◀

Inflation pressure specifications

The tables below provide all the correct inflation pressures for the specified tire sizes at ambient temperature.

 The inflation pressures apply to the tire sizes approved and tire brands recommended by BMW; a list of these is available from your BMW center. ◀

For correct identification of the right tire inflation pressures, observe the following:

- ▷ Tire sizes for your vehicle
- ▷ Maximum allowable driving speed

Tire inflation pressures for driving up to 100 mph or 160 km/h

For normal driving up to 100 mph or 160 km/h and to achieve optimum driving comfort, adjust pressures to the respective tire inflation pressures listed on the following pages in the columns for traveling speeds up to a maximum of 100 mph or 160 km/h.

These tire inflation pressures can also be found on the driver's side door pillar when the driver's door is open.



 The maximum permissible speed for these tire pressures is 100 mph or 160 km/h. Do not exceed this speed; otherwise, tire damage and accidents could occur. ◀



Tire inflation pressures for driving above 100 mph or 160 km/h





In order to drive at maximum speeds in excess of 100 mph or 160 km/h, adjust pressures to the respective tire inflation pressures listed on the following pages in the columns for traveling speeds including those exceeding 100 mph or 160 km/h. Otherwise, tire damage and accidents could occur. ◀



Observe all national and local maximum speed limits; otherwise, violations of the laws could occur.



Coupe: tire inflation pressures for the 328i

Tire size	Pressure specifications in bar/PSI			
	Traveling speeds up to a max. of 100 mph/160 km/h		Traveling speeds including those exceeding 100 mph/160 km/h	
All pressure specifications in the table are indicated in bar/PSI with cold tires. Cold = ambient temperature				
Without Sport Package:				
205/55 R 16 91 H M+S RSC				
225/50 R 16 92 H M+S RSC				
225/45 R 17 91 H M+S A/S RSC	2.2/32	2.6/38	2.5/36	3.0/44
225/45 R 17 91 H M+S RSC				
225/45 R 17 91 V RSC				
225/45 R 17 94 V M+S XL	2.2/32	2.7/39	2.5/36	3.0/44
Front: 225/45 R 17 91 V	2.2/32	-	2.5/36	-
Rear: 255/40 R 17 94 V	-	2.4/35	-	2.7/39
Front: 225/40 R 18 88 W RSC	2.2/32	-	2.5/36	-
Rear: 255/35 R 18 90 W RSC	-	2.7/39	-	2.9/42
Front: 225/35 R 19 88 Y XL	2.5/36	-	2.5/36	-
Rear: 255/30 R 19 91 Y XL	-	3.0/44	-	3.0/44
Compact spare wheel: T 125/80 R 17 99 M	Traveling speeds up to a max. of 50 mph/80 km/h 4.2/60			
With Sport Package:				
205/55 R 16 91 H M+S				
225/50 R 16 92 H M+S	2.2/32	2.6/38	2.5/36	3.0/44
225/45 R 17 91 H M+S				
225/45 R 17 91 V	2.2/32	2.6/38	2.9/42	3.4/49
225/45 R 17 94 V M+S XL	2.2/32	2.7/39	2.9/42	3.4/49
Front: 225/45 R 17 91 V	2.2/32	-	2.9/42	-
Rear: 255/40 R 17 94 V	-	2.4/35	-	3.0/44
Front: 225/40 R 18 88 W RSC	2.2/32	-	2.7/39	-
Rear: 255/35 R 18 90 W RSC	-	2.7/39	-	3.2/46

Tire size	Pressure specifications in bar/PSI	
	Traveling speeds up to a max. of 100 mph/160 km/h	Traveling speeds including those exceeding 100 mph/160 km/h
All pressure specifications in the table are indicated in bar/PSI with cold tires. Cold = ambient temperature		
	Front: 225/35 R 19 88 Y XL Rear: 255/30 R 19 91 Y XL	2.5/36 - - 3.0/44
Compact spare wheel: T 125/80 R 17 99 M	Traveling speeds up to a max. of 50 mph/80 km/h 4.2/60	

Coupe: tire inflation pressures for the 328xi



Tire size	Pressure specifications in bar/PSI			
	Traveling speeds up to a max. of 100 mph/160 km/h		Traveling speeds including those exceeding 100 mph/160 km/h	
<p>All pressure specifications in the table are indicated in bar/PSI with cold tires. Cold = ambient temperature</p>  				
Without Sport Package:				
205/55 R 16 91 H M+S RSC				
225/50 R 16 92 H M+S RSC				
225/45 R 17 91 H M+S A/S RSC	2.2/32	2.6/38	2.4/35	2.9/42
225/45 R 17 91 H M+S RSC				
225/45 R 17 91 V RSC				
225/45 R 17 94 V M+S XL	2.2/32	2.7/39	2.5/36	3.0/44
Front: 225/45 R 17 91 V	2.2/32	-	2.3/33	-
Rear: 255/40 R 17 94 V	-	2.3/33	-	2.7/39
Front: 225/40 R 18 88 W RSC	2.3/33	-	2.5/36	-
Rear: 255/35 R 18 90 W RSC	-	2.6/38	-	2.9/42
Front: 225/35 R 19 88 Y XL	2.7/39	-	2.7/39	-
Rear: 255/30 R 19 91 Y XL	-	3.0/44	-	3.0/44
Compact spare wheel: T 125/80 R 17 99 M	Traveling speeds up to a max. of 50 mph/80 km/h 4.2/60			



Tire size	Pressure specifications in bar/PSI			
	Traveling speeds up to a max. of 100 mph/160 km/h		Traveling speeds including those exceeding 100 mph/160 km/h	
All pressure specifications in the table are indicated in bar/PSI with cold tires. Cold = ambient temperature				

With Sport Package:

205/55 R 16 91 H M+S				
225/50 R 16 92 H M+S	2.2/32	2.6/38	2.4/35	2.9/42
225/45 R 17 91 H M+S				
225/45 R 17 91 V	2.2/32	2.6/38	2.8/41	3.3/48
225/45 R 17 94 V M+S XL	2.2/32	2.7/39	2.8/41	3.3/48
Front: 225/45 R 17 91 V	2.2/32	-	2.8/41	-
Rear: 255/40 R 17 94 V	-	2.3/33	-	2.9/42
Front: 225/40 R 18 88 W RSC	2.3/33	-	2.7/39	-
Rear: 255/35 R 18 90 W RSC	-	2.6/38	-	3.2/46
Front: 225/35 R 19 88 Y XL	2.7/39	-	2.8/41	-
Rear: 255/30 R 19 91 Y XL	-	3.0/44	-	3.2/46
Compact spare wheel: T 125/80 R 17 99 M	Traveling speeds up to a max. of 50 mph/80 km/h 4.2/60			

Coupe: tire inflation pressures for the 335i

Tire size	Pressure specifications in bar/PSI			
	Traveling speeds up to a max. of 100 mph/160 km/h		Traveling speeds including those exceeding 100 mph/160 km/h	
All pressure specifications in the table are indicated in bar/PSI with cold tires. Cold = ambient temperature				
Without Sport Package:				
225/45 R 17 91 H M+S	2.2/32	2.7/39	2.6/38	3.1/45
225/45 R 17 91 H M+S				
225/45 R 17 94 V M+S XL	2.3/33	2.8/41	2.6/38	3.1/45
Front: 225/45 R 17 91 V	2.2/32	-	2.6/38	-
Rear: 255/40 R 17 94 V	-	2.4/35	-	2.8/41
Front: 225/40 R 18 88 W RSC	2.2/32	-	2.6/38	-
Rear: 255/35 R 18 90 W RSC	-	2.7/39	-	3.1/45
Front: 225/40 R 18 88 Y	2.2/32	-	2.4/35	-
Rear: 255/35 R 18 90 Y	-	2.7/39	-	2.8/41
Front: 225/35 R 19 88 Y XL	2.6/38	-	2.6/38	-
Rear: 255/30 R 19 91 Y XL	-	3.1/45	-	3.1/45
Compact spare wheel: T 125/80 R 17 99 M	Traveling speeds up to a max. of 50 mph/80 km/h 4.2/60			
With Sport Package:				
225/45 R 17 91 H M+S	2.2/32	2.7/39	2.6/38	3.1/45
225/45 R 17 94 V M+S XL	2.3/33	2.8/41	2.9/42	3.4/49
Front: 225/45 R 17 91 V	2.2/32	-	2.6/38	-
Rear: 255/40 R 17 94 V	-	2.4/35	-	3.0/44
Front: 225/40 R 18 88 W RSC	2.2/32	-	2.8/41	-
Rear: 255/35 R 18 90 W RSC	-	2.7/39	-	3.3/48
Front: 225/40 R 18 88 Y	2.2/32	-	2.5/36	-
Rear: 255/35 R 18 90 Y	-	2.7/39	-	3.0/44

Tire size	Pressure specifications in bar/PSI			
	Traveling speeds up to a max. of 100 mph/160 km/h		Traveling speeds including those exceeding 100 mph/160 km/h	
All pressure specifications in the table are indicated in bar/PSI with cold tires. Cold = ambient temperature				
	Front: 225/35 R 19 88 Y XL	2.6/38	-	2.8/41
Rear: 255/30 R 19 91 Y XL	-	3.1/45	-	3.3/48
Compact spare wheel: T 125/80 R 17 99 M	Traveling speeds up to a max. of 50 mph/80 km/h 4.2/60			

Coupe: tire inflation pressures for the 335xi

Tire size	Pressure specifications in bar/PSI			
	Traveling speeds up to a max. of 100 mph/160 km/h		Traveling speeds including those exceeding 100 mph/160 km/h	

All pressure specifications in the table are indicated in bar/PSI with cold tires.
Cold = ambient temperature





Without Sport Package:



225/45 R 17 91 H M+S	2.2/32	2.7/39	2.7/39	3.1/45
225/45 R 17 91 H M+S				
225/45 R 17 94 V M+S XL	2.3/33	2.8/41	2.7/39	3.1/45
Front: 225/45 R 17 91 V	2.2/32	-	2.7/39	-
Rear: 255/40 R 17 94 V	-	2.4/35	-	2.7/39
Front: 225/40 R 18 88 W RSC	2.4/35	-	2.6/38	-
Rear: 255/35 R 18 90 W RSC	-	2.7/39	-	2.9/42
Front: 225/40 R 18 88 Y	2.4/35	-	2.4/35	-
Rear: 255/35 R 18 90 Y	-	2.7/39	-	2.7/39
Front: 225/35 R 19 88 Y XL	2.7/39	-	2.7/39	-
Rear: 255/30 R 19 91 Y XL	-	3.1/45	-	3.1/45
Compact spare wheel: T 125/80 R 17 99 M	Traveling speeds up to a max. of 50 mph/80 km/h 4.2/60			

With Sport Package:



225/45 R 17 91 H M+S	2.2/32	2.7/39	2.7/39	3.1/45
225/45 R 17 94 V M+S XL	2.3/33	2.8/41	2.9/42	3.4/49
Front: 225/45 R 17 91 V	2.2/32	-	2.7/39	-
Rear: 255/40 R 17 94 V	-	2.4/35	-	3.0/44
Front: 225/40 R 18 88 W RSC	2.4/35	-	2.9/42	-
Rear: 255/35 R 18 90 W RSC	-	2.7/39	-	3.3/48
Front: 225/40 R 18 88 Y	2.4/35	-	2.7/39	-
Rear: 255/35 R 18 90 Y	-	2.7/39	-	2.9/42



Tire size	Pressure specifications in bar/PSI			
	Traveling speeds up to a max. of 100 mph/160 km/h		Traveling speeds including those exceeding 100 mph/160 km/h	
All pressure specifications in the table are indicated in bar/PSI with cold tires. Cold = ambient temperature				
	Front: 225/35 R 19 88 Y XL	2.7/39	-	2.9/42
Rear: 255/30 R 19 91 Y XL	-	3.1/45	-	3.3/48
Compact spare wheel: T 125/80 R 17 99 M	Traveling speeds up to a max. of 50 mph/80 km/h 4.2/60			

Coupe: inflation pressures 335is



Tire size	Pressure specifications in bar/PSI			
	Traveling speeds up to a max. of 100 mph/160 km/h		Traveling speeds including those exceeding 100 mph/160 km/h	
All pressure specifications in the table are indicated in bar/PSI with cold tires. Cold = ambient temperature				
225/45 R 17 91 H M+S	2.2/32	2.7/39	2.6/38	3.1/45
225/45 R 17 94 V M+S XL	2.4/35	2.9/42	3.0/44	3.4/49
Front: 225/40 R 18 88 W RSC	2.3/33	-	2.9/42	-
Rear: 255/35 R 18 90 W RSC	-	2.8/41	-	3.4/49
Front: 225/40 R 18 88 Y	2.3/33	-	2.6/38	-
Rear: 255/35 R 18 90 Y	-	2.8/41	-	3.1/45
Front: 225/35 R 19 88 Y XL	2.7/39	-	2.9/42	-
Rear: 255/30 R 19 91 Y XL	-	3.2/46	-	3.4/49
Compact spare wheel: T 125/80 R 17 99 M	Traveling speeds up to a max. of 50 mph/80 km/h 4.2/60			

Convertible: tire inflation pressures for the 328i

Tire size	Pressure specifications in bar/PSI			
	Traveling speeds up to a max. of 100 mph/160 km/h		Traveling speeds including those exceeding 100 mph/160 km/h	
All pressure specifications in the table are indicated in bar/PSI with cold tires. Cold = ambient temperature				
	<hr/> Without Sport Package:			
205/55 R 16 91 H M+S	2.3/33	2.8/41	2.5/36	3.0/44
225/50 R 16 92 H M+S				
225/45 R 17 91 H M+S	2.3/33	2.8/41	2.7/39	3.2/46
225/45 R 17 91 H M+S				
225/45 R 17 91 W RSC	2.3/33	2.8/41	2.5/36	3.0/44
225/45 R 17 94 V M+S XL	2.4/35	2.9/42	2.7/39	3.2/46
Front: 225/45 R 17 91 V	2.2/32	-	2.5/36	-
Rear: 255/40 R 17 94 V	-	2.5/36	-	2.9/42
Front: 225/40 R 18 88 W RSC	2.4/35	-	2.6/38	-
Rear: 255/35 R 18 90 W RSC	-	2.9/42	-	3.1/45
Front: 225/40 R 18 88 Y	2.4/35	-	2.4/35	-
Rear: 255/35 R 18 90 Y	-	2.9/42	-	2.9/42
Front: 225/35 R 19 88 Y XL	2.7/39	-	2.7/39	-
Rear: 255/30 R 19 91 Y XL	-	3.2/46	-	3.2/46
Compact spare wheel: T 125/80 R 17 99 M	Traveling speeds up to a max. of 50 mph/80 km/h 4.2/60			

Tire size	Pressure specifications in bar/PSI			
	Traveling speeds up to a max. of 100 mph/160 km/h		Traveling speeds including those exceeding 100 mph/160 km/h	
All pressure specifications in the table are indicated in bar/PSI with cold tires. Cold = ambient temperature				
With Sport Package:				
205/55 R 16 91 H M+S	2.3/33	2.8/41	2.5/36	3.0/44
225/50 R 16 92 H M+S				
225/45 R 17 91 H M+S RSC	2.3/33	2.8/41	2.8/41	3.3/48
225/45 R 17 91 W RSC				
225/45 R 17 94 V M+S XL	2.4/35	2.9/42	2.9/42	3.4/49
Front: 225/45 R 17 91 V	2.2/32	-	2.8/41	-
Rear: 255/40 R 17 94 V	-	2.5/36	-	3.1/45
Front: 225/40 R 18 88 W RSC	2.4/35	-	2.9/42	-
Rear: 255/35 R 18 90 W RSC	-	2.9/42	-	3.4/49
Front: 225/40 R 18 88 Y	2.4/35	-	2.6/38	-
Rear: 255/35 R 18 90 Y	-	2.9/42	-	3.1/45
Front: 225/35 R 19 88 Y XL	2.7/39	-	2.9/42	-
Rear: 255/30 R 19 91 Y XL	-	3.2/46	-	3.4/49
Compact spare wheel: T 125/80 R 17 99 M	Traveling speeds up to a max. of 50 mph/80 km/h 4.2/60			

Convertible: tire inflation pressures for the 335i



Tire size	Pressure specifications in bar/PSI			
	Traveling speeds up to a max. of 100 mph/160 km/h		Traveling speeds including those exceeding 100 mph/160 km/h	
All pressure specifications in the table are indicated in bar/PSI with cold tires. Cold = ambient temperature				

Without Sport Package:



225/45 R 17 91 H M+S	2.3/33	2.8/41	2.7/39	3.2/46
225/45 R 17 91 H M+S				
225/45 R 17 94 V M+S XL	2.4/35	2.9/42	2.7/39	3.2/46
Front: 225/45 R 17 91 V	2.2/32	-	2.5/36	-
Rear: 255/40 R 17 94 V	-	2.5/36	-	2.9/42
Front: 225/40 R 18 88 W RSC	2.4/35	-	2.6/38	-
Rear: 255/35 R 18 90 W RSC	-	2.9/42	-	3.1/45
Front: 225/40 R 18 88 Y	2.4/35	-	2.4/35	-
Rear: 255/35 R 18 90 Y	-	2.9/42	-	2.9/42
Front: 225/35 R 19 88 Y XL	2.7/39	-	2.7/39	-
Rear: 255/30 R 19 91 Y XL	-	3.2/46	-	3.2/46
Compact spare wheel: T 125/80 R 17 99 M	Traveling speeds up to a max. of 50 mph/80 km/h 4.2/60			

With Sport Package:

225/45 R 17 91 H M+S	2.3/33	2.8/41	2.7/39	3.2/46
225/45 R 17 94 V M+S XL	2.4/35	2.9/42	2.9/42	3.4/49
Front: 225/45 R 17 91 V	2.2/32	-	2.8/41	-
Rear: 255/40 R 17 94 V	-	2.5/36	-	3.1/45
Front: 225/40 R 18 88 W RSC	2.4/35	-	2.9/42	-
Rear: 255/35 R 18 90 W RSC	-	2.9/42	-	3.4/49
Front: 225/40 R 18 88 Y	2.4/35	-	2.6/38	-
Rear: 255/35 R 18 90 Y	-	2.9/42	-	3.1/45

Tire size	Pressure specifications in bar/PSI			
<p>All pressure specifications in the table are indicated in bar/PSI with cold tires. Cold = ambient temperature</p>	<p>Traveling speeds up to a max. of 100 mph/160 km/h</p>	<p>Traveling speeds including those exceeding 100 mph/160 km/h</p>		
				
Front: 225/35 R 19 88 Y XL	2.7/39	-	2.9/42	-
Rear: 255/30 R 19 91 Y XL	-	3.2/46	-	3.4/49
<p>Compact spare wheel: T 125/80 R 17 99 M</p>	<p>Traveling speeds up to a max. of 50 mph/80 km/h 4.2/60</p>			

Convertible: inflation pressures 335is

Tire size	Pressure specifications in bar/PSI			
	Traveling speeds up to a max. of 100 mph/160 km/h		Traveling speeds including those exceeding 100 mph/160 km/h	
All pressure specifications in the table are indicated in bar/PSI with cold tires. Cold = ambient temperature				
225/45 R 17 91 H M+S	2.3/33	2.8/41	2.7/39	3.2/46
225/45 R 17 94 V M+S XL	2.4/35	2.9/42	2.9/42	3.4/49
Front: 225/40 R 18 88 W RSC	2.4/35	-	2.9/42	-
Rear: 255/35 R 18 90 W RSC	-	2.9/42	-	3.4/49
Front: 225/40 R 18 88 Y	2.4/35	-	2.6/38	-
Rear: 255/35 R 18 90 Y	-	2.9/42	-	3.1/45
Front: 225/35 R 19 88 Y XL	2.7/39	-	2.9/42	-
Rear: 255/30 R 19 91 Y XL	-	3.2/46	-	3.4/49
Compact spare wheel: T 125/80 R 17 99 M	Traveling speeds up to a max. of 50 mph/80 km/h 4.2/60			

Tire identification marks

Knowledge of the labeling on the side of the tire makes it easier to identify and choose the right tires.

Tire size

e.g. 225/45 R 17 91 V

Nominal width in mm ————|
 Aspect ratio in % ————|
 Radial belt construction ————|
 Rim diameter in inches ————|
 Load rating, not on ZR tires ————|
 Speed code letter, in front of the R on ZR tires ————|

Speed code letter

Q = up to 100 mph or 160 km/h

T = up to 118 mph or 190 km/h

H = up to 131 mph or 210 km/h

V = up to 150 mph or 240 km/h

W = up to 167 mph or 270 km/h

Y = up to 186 mph or 300 km/h

Tire Identification Number

Tires with DOT codes meet the guidelines of the US Department of Transportation.

DOT code:

e.g. DOT xxxx xxx 1011

Manufacturer's code for tire make ————|
 Tire size and tire design ————|
 Tire age ————|

Tire age

The manufacturing date of tires is contained in the tire coding: DOT ... 1011 means that the tire was manufactured in week 10 of 2011.

BMW recommends that you replace all tires after 6 years at most, even if some tires may last for 10 years.

Uniform Tire Quality Grading

Quality grades can be found where applicable on the tire sidewall between tread shoulder and maximum section width. For example:

Tread wear 200 Traction AA

Temperature A

DOT Quality Grades

Tread wear

Traction AA A B C

Temperature A B C



All passenger car tires must conform to Federal Safety Requirements in addition to these grades. ◀

Tread wear

The tread wear grade is a comparative rating based on the wear rate of the tire when tested under controlled conditions on a specified government test course. For example, a tire graded 150 would wear one and one-half (1 ½) times as well on the government course as a tire graded 100. The relative performance of tires depends upon the actual conditions of their use, however, and may depart significantly from the norm due to variations in driving habits, service practices and differences in road characteristics and climate.

Traction

The traction grades, from highest to lowest, are AA, A, B, and C.

Those grades represent the tire's ability to stop on wet pavement as measured under controlled conditions on specified government test surfaces of asphalt and concrete. A tire marked C may have poor traction performance.



The traction grade assigned to this tire is based on straight-ahead braking traction tests, and does not include acceleration, cornering, hydroplaning, or peak traction characteristics. ◀

Temperature

The temperature grades are A, the highest, B, and C, representing the tire's resistance to the generation of heat and its ability to dissipate heat when tested under controlled conditions on a specified indoor laboratory test wheel. Sustained high temperature can cause the material of the tire to degenerate and reduce tire life, and excessive temperature can lead to sudden tire failure. The grade C corresponds to a level of performance which all passenger car tires must meet under the Federal Motor Vehicle Safety Standard No. 109. Grades B and A represent higher levels of performance on the laboratory test wheel than the minimum required by law.

 The temperature grade for this tire is established for a tire that is properly inflated and not overloaded. Excessive speed, underinflation, or excessive loading, either separately or in combination, can cause heat buildup and possible tire failure. ◀

RSC – run-flat tires

You will recognize run-flat tires by a circular symbol containing the letters RSC on the side of the tire, refer to page 195.

M+S

Winter and all-season tires. These have better winter properties than summer tires.

XL

Designation for specially reinforced tires.

Tire condition

Inspect your tires frequently for tread wear, signs of damage and for foreign objects lodged in the tread. Check the tread depth.

Minimum tread depth

The tread depth should not drop below 0.12 in/3 mm, although, for example, European legislation only specifies a minimum tread depth of 0.063 in/1.6 mm. At tread depths below 0.12 in/3 mm there is an increased risk of high-speed hydroplaning, even when only small amounts of water are present on the road surface. When winter tires wear down past a tread depth of 0.16 in/4 mm, they become perceptibly less suitable for winter conditions. In the interest of safety, new tires should be installed.

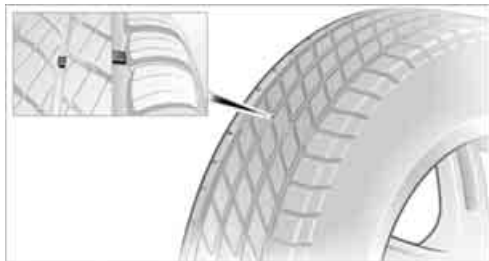

Wear indicators in the base of the tread groove are distributed around the tire's circumference; the letters TWI, for Tread Wear Indicator, on the tire's sidewalls identify tires that incorporate these wear indicators. Once the tire tread has worn down to the wear indicators, the tire has worn to a depth of 0.063 in/1.6 mm.

Wheel/tire damage

Driving over rough or damaged road surfaces, as well as debris, curbs and other obstacles can cause serious damage to wheels, tires, and suspension parts. This is more likely to occur with low-profile tires, which provide less cushioning between the wheel and the road. Be careful to avoid road hazards and reduce your speed, especially if your vehicle is equipped with low-profile tires.

Unusual vibrations encountered during normal vehicle operation can indicate tire failure or some other vehicle defect. This can, for example, be caused by driving over curbs. The same applies to any other abnormal road behavior, such as pulling severely to the right or left.

! In these cases, reduce speed immediately and have wheels and tires thoroughly checked. To do so, drive carefully to the nearest BMW center or tire dealer. If necessary, have the vehicle towed there.

Otherwise, tire damage can pose a lethal hazard to vehicle occupants and other road users. ◀

Tire age

For various reasons, such as the development of brittleness, BMW recommends tire replacement after no more than 6 years, regardless of the actual wear of the tires.

The manufacturing date of tires is contained in the tire coding:

DOT... 3010 means that the tire was manufactured in week 30 of 2010.

New wheels and tires

! Have new wheels and tires mounted only by your BMW center or by a tire dealer. If this work is not carried out properly, there is a danger of subsequent damage and related safety hazards. Make sure that the new wheels are balanced. ◀

Retreaded tires

! BMW recommends that you do not use retreaded tires, since driving safety may be impaired. The causes for this include potentially different tire casing structures and often wide variations in tire age, which can result in a limited service life. ◀

Correct wheels and tires

When mounting new tires or changing over from summer to winter tires and vice versa, mount run-flat tires for your own safety. In the event of a flat, no spare wheel is available. Your BMW center will be glad to advise you.

! BMW recommends that you use only wheel and tire combinations that BMW has tested and approved for your particular vehicle. Variations in factors such as manufac-

turing tolerances mean that even wheels and tires with identical official size ratings could actually have different dimensions, which could lead to body contact and thus to severe accidents. If non-approved wheels and tires are used, BMW cannot evaluate their suitability, and therefore cannot guarantee their driving safety. ◀

You can inquire about the right wheel/tire combination at your BMW center.

The correct combination of wheels and tires is also necessary to ensure reliable operation of various vehicle systems such as ABS, DSC or FTM.

To maintain good handling and vehicle response, use only tires of a single brand and tread configuration. After a tire has been damaged, mount the previous wheel and tire combination again as soon as possible.

Wheels with Tire Pressure Monitor TPM electronics

When mounting new tires or changing over from summer to winter tires, or vice versa, only use wheels with TPM electronics; otherwise, the Tire Pressure Monitor may not be able to detect a puncture, refer to page 95. Your BMW center will be glad to advise you.

Recommended tire brands

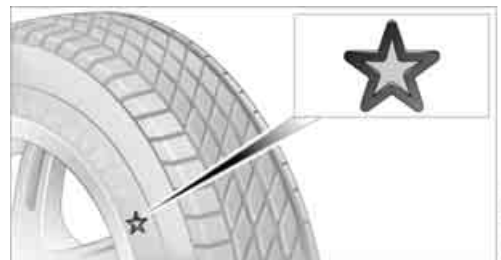

Certain makes of tire are recommended by BMW for each tire size. They are marked with a clearly visible BMW designation on the sidewall of the tire.

When properly used, these tires meet the highest standards in terms of safety and handling characteristics.

Special characteristics of winter tires

BMW recommends winter tires for driving on winter roads or at temperatures below +45 °F / +7 °C. Although all-season M+S tires provide better winter traction than summer tires, they generally fail to provide the same levels of cold-weather performance as winter tires.

Pay attention to speed



Always comply with the speed limit for the winter tires mounted on your car; failure to do so could result in tire damage and accidents. ◀

If the car is capable of speeds higher than that permitted for the winter tires, a label stating the maximum permitted speed for the mounted tires must be displayed in your field of view. Specialist tire dealers and your BMW center can supply these labels.

Storage

Always store wheels and tires in a cool, dry place with as little exposure to light as possible. Always protect tires against all contact with oil, grease and fuels. Do not exceed the maximum tire inflation pressure indicated on the sidewall of the tire.

Swapping wheels between axles

BMW advises against swapping wheels between the front and rear axles, even if all tires have the same size, as this could impair driving characteristics. If the tires are of mixed sizes, swapping wheels between the axles is not permissible.

Run-flat tires



The symbol identifying run-flat tires is a circle with the letters RSC on the sidewall.

Run-flat tires comprise a conditionally self-supporting tire and a special rim. The reinforcement in the sidewalls ensures that the tire can continue to be used subject to certain restrictions, even if depressurized.

For information on continuing to drive with a flat tire, refer to Indication of a flat tire, page 94.

Snow chains

Only certain fine-link snow chains have been tested by BMW, classified as safe for use and recommended. Consult your BMW center for more information.

Snow chains must be mounted in pairs and on the rear wheels only. Observe the manufacturer's instructions when mounting snow chains. Do not exceed a speed of 30 mph or 50 km/h.



Do not initialize the Flat Tire Monitor if snow chains are mounted; otherwise, the instrument might issue an incorrect reading. When driving with snow chains, you may find it helpful to activate DTC temporarily, refer to page 91. ◀

Engine compartment

Vehicle equipment

In this chapter, all production, country, and optional equipment that is offered in the model range is described. For this reason, descriptions will be given of some equipment that may

not be available in a vehicle, for example due to the special options or national-market version selected. This also applies to safety related functions and systems.

Important parts of the engine compartment

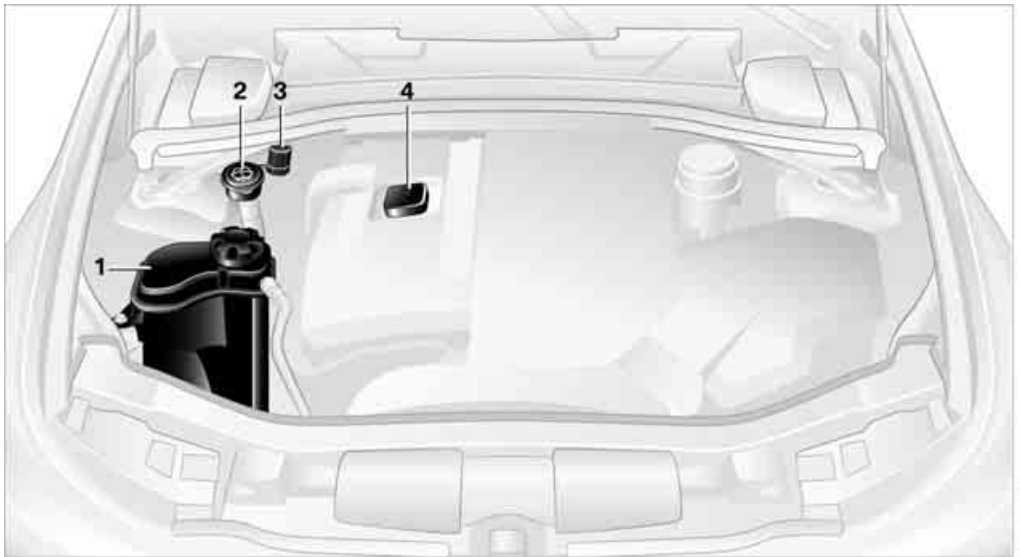

- 1** Expansion tank for coolant, refer to page [200](#)
- 2** Washer fluid filler neck for headlamp cleaning system and window washer system, refer to page [69](#)
- 3** Jump-starting connection, refer to page [216](#)
- 4** Filler neck for engine oil, refer to Adding engine oil

Hood

! Do not work on the car unless you possess the necessary technical knowledge. If you are not familiar with the regulations to be followed, have the necessary work on the vehicle carried out only by your BMW center; if this work is not carried out properly, there is a danger of subsequent damage and related safety hazards. ◀

Releasing

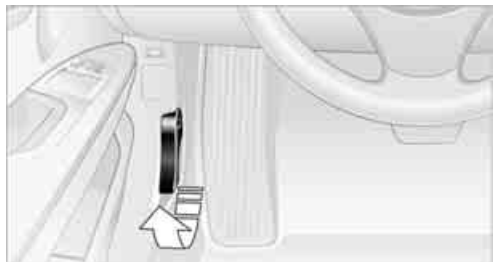

Pull the lever.

Opening



! In order to avoid damage, make sure that the wiper arms are against the windshield before you open the hood. Do not open the engine hood before the engine has cooled down; otherwise, injuries may result. ◀

Press the release handle and open the hood.

Closing



Let the hood drop from a height of approx. 10 in/ 25 cm. It must be clearly heard to engage.

! Make sure that the closing path of the hood is clear; otherwise, injuries may result.

If you see any signs while driving your vehicle that the hood is not completely closed, stop at once and close it securely. ◀

Engine oil

The engine oil consumption is dependent on driving style and driving conditions.

Checking oil level

Your car is equipped with an electronic oil-level monitor.

For a precise measurement and display of the oil level, it is necessary that the engine be at operating temperature, i.e. after uninterrupted driving for at least approx. 6.2 miles/10 km. You can have the oil level displayed while you are driving, or while the vehicle is at a standstill on a level surface and the engine is running.

You can have the oil level reading displayed in the instrument cluster.



1. Push button **1** in the turn signal/high beam lever up or down repeatedly until the appropriate symbol is shown in the display, accompanied by the word "OIL".
2. Press button **2** in the turn signal/high beam lever.
The oil level is checked and the reading displayed.

Possible displays



- 1 Oil level OK
- 2 Oil level is being checked.
This can take about 3 minutes if the car is at a standstill on a level surface, or about 5 minutes while the car is on the move.

- 3 Oil level down to minimum:
Add engine oil as soon as possible, but no more than 1 US quart/1 liter, refer also to Adding engine oil on page 199.

- 4 Oil level is too high.



Too much oil will harm the engine. Have the vehicle checked without delay. ◀

- 5 The oil level sensor is defective.
Do not add engine oil. You can continue your journey. Note the newly calculated distance remaining to the next oil service, refer to page 84. Have the system checked as soon as possible.

Adding engine oil

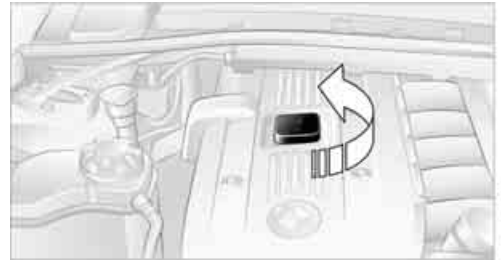

Do not add 1 US quart/1 liter of engine oil until the following warning lamp lights up in the instrument cluster, or until the oil level monitor shows "+1qt" or "+1l".





 Add oil within the next 125 miles/200 km; otherwise, the engine could be damaged. ◀

 If the engine oil is too high, have the vehicle checked immediately; failure to do so may result in engine damage. ◀

 Keep oils, greases, etc. out of the reach of children and comply with the relevant warnings on the containers. Otherwise, health hazards may result. ◀

Oil grades to add

 Do not use oil additives as this could result in engine damage. ◀

 When selecting an engine oil, make sure to use one from the SAE viscosity classes 0W-40, 0W-30, 5W-40 or 5W-30; failure to do so may result in malfunctions or engine damage. ◀

The engine oil quality is critical for the life of the engine.

Some oil grades may not be available in all countries.

Approved oil grades

Gasoline engine

BMW High Performance SAE 5W-30

BMW Longlife-01

BMW Longlife-01 FE

Diesel engine

BMW Longlife-04

Additional information about approved oil grades is available at your BMW center.

Alternative oil types

If approved oils are not available, you can add quantities of up to 1 US quart/1 liter of another oil with the following specifications:

Gasoline engine

API SM or higher

Diesel engine

API ILSAC GF-5

Oil change

Oil changes should only be performed by a BMW center.

BMW recommends 

Coolant

Coolant consists of half water and half additive. Not all commercially available additives are suitable for your BMW. Ask your BMW center about suitable additives.

 Only use suitable additives; otherwise, engine damage may result. Because additives are harmful to your health, it is important to follow the instructions on the containers. ◀

 Comply with the appropriate environmental protection regulations when disposing of coolant additives. ◀

Coolant temperature

If the coolant and therefore the engine overheats, a warning lamp lights up, refer to page 220.

Checking coolant level

 Do not add coolant to the cooling system when the engine is hot. Escaping coolant can cause burns. ◀

1. Do not open the engine hood before the engine has cooled down.
2. Turn the cap of the expansion tank a little counterclockwise to allow any accumulated pressure to escape, then continue turning to open.
3. The coolant level is correct if it is between the maximum and minimum marks in the filler neck, refer also to the diagram next to the filler neck.



4. If the coolant is low, slowly add coolant up to the specified level; do not overfill.
5. Turn the cap until there is an audible click.
6. Have the reason for the coolant loss eliminated as soon as possible.

Maintenance

Vehicle equipment

In this chapter, all production, country, and optional equipment that is offered in the model range is described. For this reason, descriptions will be given of some equipment that may not be available in a vehicle, for example due to the special options or national-market version selected. This also applies to safety related functions and systems.

BMW Maintenance System



The BMW maintenance system advises you of necessary maintenance measures and helps you maintain the traffic and operating safety of the vehicle.

Condition Based Service CBS

Sensors and special algorithms take the different driving conditions of your BMW into account. Condition Based Service uses this to determine the current and future service requirements. By letting you define a service and maintenance regimen that reflects your own individual requirements, the system builds the basis for trouble-free driving.

In the instrument cluster, you can have the remaining times or distances for selected maintenance tasks and any legally prescribed dates displayed, refer to page 84:

- ▷ Engine oil
- ▷ Brake pads: separately for front and rear
- ▷ Brake fluid
- ▷ Vehicle check
- ▷ Legally mandated inspections depending on local regulations

Service data in the remote control

Your vehicle continuously stores service-requirement information in the remote control while you are driving. Your dealership Service Advisor can read out this data from the remote control unit, and propose an optimized maintenance approach. Whenever you take your car in for servicing you should therefore give your dealership Service Advisor the remote control unit that you last used.



Make sure that the date in the instrument cluster is always set correctly, refer to page 86; otherwise, the effectiveness of Condition Based Service CBS is not assured. ◀

Service and Warranty Information Booklet for US models and Warranty and Service Guide Booklet for Canadian models

Please consult your Service and Warranty Information Booklet for US models and Warranty and Service Guide Booklet for Canadian models for additional information on service requirements.



BMW recommends that you have service and repair operations performed at your BMW center.

Take the time to ensure that these service procedures are confirmed by entries in your vehicle's Service and Warranty Information Booklet for US models and Warranty and Service Guide Booklet for Canadian models. These entries verify that your vehicle has received the specified regular maintenance. ◀

Socket for Onboard Diagnosis OBD

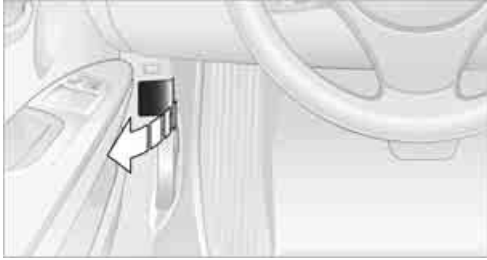

On the driver's side is an OBD socket for checking components relevant to the composition of the vehicle's emissions.

Emissions

SERVICE ENGINE SOON The warning lamp lights up: The vehicle is producing higher emissions. The trip can be continued. Have the car checked as soon as possible.



Canadian models display this warning lamp.

The lamp flashes under certain conditions. This indicates excessive misfiring in the engine. If this happens, you should reduce your speed and visit your nearest BMW center as soon as possible. Severe engine misfiring can quickly lead to serious damage of emissions-related components, especially the catalytic converter.



The warning lamp lights up if the fuel cap is not properly tightened and the OBD system assumes that fuel vapor is escaping. Make sure that the fuel cap is correctly positioned and close it until it audibly clicks.

Data memory

Your vehicle records data about the operation, faults, and user settings. These data are stored in the vehicle and in extract form, in the remote control, and can be read out using suitable devices at your BMW center. The data that are read out are used to support service procedures and repairs or to optimize and expand vehicle functions. If you have a BMW Assist contract, certain vehicle data can also be transmitted directly from the vehicle in order to enable the desired services.

Care

Vehicle equipment

In this chapter, all production, country, and optional equipment that is offered in the model range is described. For this reason, descriptions will be given of some equipment that may not be available in a vehicle, for example due to the special options or national-market version selected. This also applies to safety related functions and systems.

Care products

Regular cleaning and care contributes significantly to the value retention of your BMW.

BMW recommends cleaning and caring for your vehicle with products that are approved by BMW for this purpose.

Your BMW center will be happy to advise you on the products and services available for cleaning and caring for your BMW.

 Original BMW CareProducts have been material-tested, laboratory-checked and proven in the field, and offer optimal care and protection for your vehicle. ◀

 Do not use cleaners that contain alcohol or solvents as these may result in damage. ◀

 Cleaning agents can contain substances that are dangerous or hazardous to your health. Therefore, follow the warning and safety instructions on the packaging. When cleaning inside the vehicle, always open the doors or windows of the vehicle. In enclosed areas, provide for sufficient ventilation. Only use products designed for cleaning vehicles. ◀

Exterior care

Washing the vehicle

 Especially during the winter months, ensure that the vehicle is washed more frequently. Heavy soiling and road salt can lead to vehicle damage. ◀

 After washing the vehicle, apply the brakes briefly to dry them; otherwise, water can reduce braking efficiency over the short term and the brake discs can corrode. ◀

Automatic car washes

Give preference to car washes that use cloth or soft brushes in order to avoid paint damage.

 Do not use high-pressure car washes; otherwise, water may drip into the vehicle around the windows. ◀

Before driving into a car wash, ensure that it is suitable for your BMW. Check the following:

- ▷ Dimensions of your vehicle, refer to page 235.
- ▷ If necessary: fold in the exterior mirrors, refer to page 50.
- ▷ Maximum permissible tire width.

 Avoid car washes with guide rail heights over 4 in/10 cm; otherwise, there is the danger of damaging chassis parts. ◀

Preparations before driving into an automatic car wash:

- ▷ Unscrew the rod antenna.
- ▷ Deactivate the rain sensor to prevent undesired wiper operation.
- ▷ Remove additional add-on parts, e.g. spoilers or phone antennas, if they could be damaged.
- ▷ Leave the remote control in the ignition lock.

Automatic transmission

Before driving into an automatic car wash, perform the following steps to ensure that the vehicle can roll:

1. Insert the remote control into the ignition lock, even with Comfort Access.
2. Move the selector lever to position N.
3. Release the parking brake.
4. Switch off the engine.
5. Leave the remote control in the ignition lock so that the vehicle can roll.

Sport automatic transmission with double clutch

Before driving into an automatic car wash, perform the following steps to ensure that the vehicle can roll:

1. Insert the remote control into the ignition lock, even with Comfort Access.
2. Engage transmission position N.
3. Release the parking brake.
4. Switch off the engine.
5. Leave the remote control in the ignition lock so that the vehicle can roll.

The transmission is switched into position P:

- ▷ Automatically after approx. 30 minutes
- ▷ If you remove the infrared remote control from the ignition lock

Steam jets/high-pressure washers

 When using steam jets or high-pressure washers, make sure to maintain sufficient distance from the vehicle and do not exceed a temperature of 140 °F /60 °C.

Insufficient clearance or excessive pressure or temperature can lead to component damage or water penetration. Follow the operating instructions of the high-pressure washer. ◀

 When using high-pressure washers, do not spray the sensors, e.g. of the Park Distance Control, for an extended period and

maintain a distance of at least 1 ft/30 cm from them. ◀

Manual car wash

When washing the vehicle by hand, use large quantities of water and car shampoo if necessary. Clean the vehicle with a sponge or washing brush, applying light pressure only.

 Before cleaning the windshield, deactivate the rain sensor or switch off the ignition to prevent unintentional activation of the wipers. ◀

 Observe local regulations pertaining to washing vehicles by hand. ◀

Headlamps

Do not rub them dry and do not use abrasive or corrosive cleaning agents.

Loosen dirt, e.g. insects, with shampoo or insect remover and wash away with copious quantities of water.

Thaw ice with a windshield deicer and do not use an ice scraper.

Windows

Clean the inside and outside surfaces of the windows and the mirrors with window cleaner.

 Do not clean the mirrors with cleaners containing quartz. ◀

Convertible: retractable hardtop

Proceed as you would in a normal car wash.

 When you open a wet hardtop, water drops may run into the cargo area. If necessary, remove items from the cargo area beforehand to avoid water stains or soiling. ◀

Paintwork care

Regular care contributes to value retention and protects the paintwork against the long-term effects of damaging substances.

Region-specific environmental influences can damage the vehicle paintwork. Therefore, it is

important to adapt the frequency and scope of car care accordingly.

Immediately remove aggressive materials such as spilled fuel, oil, grease, brake fluid, tree sap or bird droppings to prevent damage to the paintwork.

Repairing paintwork damage

 Immediately repair scratches or similar damage, such as that caused by stones hitting the vehicle, where necessary to prevent rusting. ◀

BMW recommends having paintwork damage repaired by a professional paint repair workshop according to BMW specifications using original BMW paint materials.

Preservation

A preservation treatment is necessary when water no longer beads off the clean paintwork surface. Only use products for paintwork preservation that contain carnauba or synthetic waxes.

Rubber seals

Treat only with water or rubber care products.

 Do not use silicon-containing care products on rubber seals; otherwise, noise and damage could occur. ◀

Chrome parts

Carefully clean vehicle parts such as the radiator grill, door handles or window frames with copious quantities of water and a shampoo additive, especially when roads are treated with deicing salt. For additional treatment, use a chrome polish.

Light-alloy wheels

For technical reasons, dust is generated during braking that is deposited on the light-alloy wheels. Remove the dust regularly using acid-free rim cleaner.

 Do not use aggressive, acidic, strongly alkaline, or abrasive cleaning agents and do not use steam jets hotter than of 140 °F / 60 °C; otherwise, damage may occur. ◀

Outside sensors/cameras

 Keep the sensors and cameras on the outside of the vehicle, e.g. those for Park Distance Control, clean and free of ice to ensure that they remain fully functional. ◀

Interior care

Upholstery fabrics/cloth trims/ Alcantara fabrics

Vacuum regularly with a vacuum cleaner to remove superficial dirt.

To remove severe spots such as stains from beverages, use a soft sponge or lint-free microfiber cloth and suitable interior cleaners. Follow the instructions on the packaging.

 Clean the upholstery down to the seams using a sweeping motion. Avoid strong rubbing. ◀

 Opened Velcro fasteners on pants or other articles of clothing can damage the seat covers. Ensure that Velcro fasteners are closed. ◀

Leather/leather trim

 The leather used by BMW is a high quality natural product. Slight irregularities in the leather are a typical characteristic of natural leather. ◀

Dust and road grit in the pores and folds of the leather have an abrasive effect, leading to increased wear and causing the leather surface to become brittle prematurely. Therefore, frequently clean the leather of dust using a cloth or vacuum cleaner.

Clean light-colored leather more frequently as dust and dirt are more noticeable.

Treat the leather at least once every two months using a leather lotion as dirt and grease will gradually attack the leather's protective layer.

Carpet and floor mats

 Keep floor mats, carpet, and other objects out of the movement range of the pedals; otherwise, they may inhibit the function of the pedals during driving. Do not place additional floor mats onto an existing one or onto other objects. Only use floor mats that have been approved for the vehicle and can be appropriately fastened. Make sure that the floor mats are securely fastened again after they have been removed, e.g. for cleaning. ◀

Interior plastic parts

- ▷ Imitation leather surfaces
- ▷ Lamp glasses
- ▷ Display pane of instrument cluster
- ▷ Matte parts

Clean with water and solvent-free plastic cleaner if necessary.

Fine wood parts

Clean fine wood trim and fine wood parts with a damp cloth. Wipe dry with a soft cloth.

Safety belts

Dirty belt straps impede the reeling action and thus have a negative impact on safety.

 Do not clean chemically, as this may destroy the webbing. ◀

Interior sensors/cameras

To clean interior sensors and cameras, use a lint-free cloth moistened with glass cleaner.

Displays

To clean displays, e.g. of the radio or instrument cluster, use a cleaning cloth for displays or a soft, non-abrasive, lint-free cloth.

 Avoid applying excessive pressure when cleaning the displays; otherwise, damage may occur. ◀

 Do not use chemical or abrasive household cleaning agents. Keep all types of fluid away from the device. Otherwise, surfaces or electrical components may be corroded or damaged. ◀

CD/DVD drives

 Do not use a cleaning CD, as it may damage parts of the drive. ◀

Vehicle storage

If you plan to park your vehicle for longer than three months, your BMW center will be happy to advise you.

Replacing components

Vehicle equipment

In this chapter, all production, country, and optional equipment that is offered in the model range is described. For this reason, descriptions will be given of some equipment that may not be available in a vehicle, for example due to the special options or national-market version selected. This also applies to safety related functions and systems.

Onboard vehicle tool kit

Coupe



The onboard vehicle tool kit is stored in a compartment on the right-hand side of the cargo area. Remove the cover.

Convertible

The onboard vehicle tool kit is stored in a pouch under the cargo area floor panel.

Wiper blades

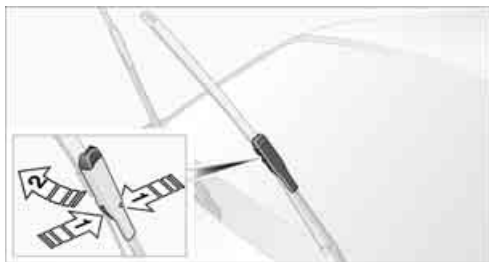

1. Fold out the wiper arm and hold it.
2. Press together the locking spring, arrows **1**, and fold out the wiper blade, arrow **2**.
3. Take the wiper blade out of the catch mechanism, pulling the blade toward the front.

⚠ To avoid damage, make sure that the wiper arms are against the windshield before you open the hood. ◀

Lamps and bulbs

Lamps and bulbs make an essential contribution to vehicle safety. They should, therefore, be handled carefully. BMW recommends having your BMW center perform any work that you do not feel competent to perform yourself or that is not described here.

▷ Never touch the glass of new bulbs with your bare fingers, as even minute amounts of contamination will burn into the bulb's surface and reduce its service life. Use a clean tissue, cloth or something similar, or hold the bulb by its base. ◀

Replacement bulb sets are available at your BMW center.

⚠ Only change bulbs while they are cool to the touch; otherwise, you could suffer burns. ◀

! When working on electrical systems, always begin by switching off the consumer in question; otherwise, short-circuits could result. To avoid possible injury or equipment damage when replacing bulbs, observe any instructions provided by the bulb manufacturer. ◀

For care of the headlamps, please follow the instructions in the chapter entitled 'Care'.

▷ To replace lamps not described here, please contact your BMW center. ◀

Light-emitting diodes LED

Light-emitting diodes installed behind translucent lenses serve as the light source for many of the controls, displays, and equipment in your vehicle. These light-emitting diodes, which operate using a concept similar to that applied in conventional lasers, are officially designated as Class 1 light-emitting diodes.

! Do not remove the covers or expose the eyes directly to the unfiltered light source for several hours; otherwise, this could cause irritation of the retina. ◀

Headlight lenses

In cool or humid weather, condensation may form on the interior of outside lamps. The condensation will disappear after a short time when driving with the headlamps switched on. The headlamp glasses do not need to be changed.

If the headlamps do not defrost despite driving with the headlamps switched on, and additional moisture builds up, for example water droplets in the lamps, have them checked by your BMW center.

Xenon lamps

These bulbs have a very long service life and are highly unlikely to fail. If a xenon lamp fails nevertheless, switch on the fog lamps and continue the journey with great care, provided that local legislation does not prohibit this.

! Have all work on the xenon lamp system, including bulb replacements, performed only by your BMW center. Due to high voltage, there is a risk of fatal injury if work on the xenon lamps is carried out improperly. ◀

Access to the lamps

1. Switch off the lamps and take the remote control out of the ignition lock.
2. Remove the upper cover from the headlamp. To do so, use a screwdriver to press the catches towards the rear, see arrows, and pull the cover forward and out.

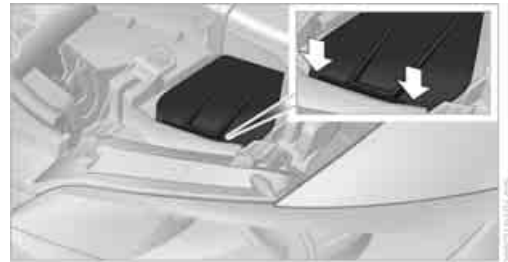

Follow the same steps in reverse order to reattach the cover.

! Be careful when installing the cover; otherwise, leaks could occur and cause damage to the headlamp system. ◀

Parking lamps and roadside parking lamps, daytime running lights

These lamps use LED technology for operation. If they malfunction, please contact your BMW center.

Corner-illuminating lamps

H3 bulb, 55 watts

1. Switch off the lamps and take the remote control out of the ignition lock.
2. Remove the cover, refer to Access to the lamps.

3. Push the wire bracket out of the anchor towards the right and fold it up.



4. Disconnect the plug, change the bulb and reconnect the plug.
5. Insert the bulb.
6. Fold the wire bracket down and engage it.
7. Reattach the cover.

Turn signals, front

These lamps use LED technology for operation. If they malfunction, please contact your BMW center.

Side turn signals

W5W bulb, 5 watts

1. Press the front edge of the lamp toward the rear with your fingertip, arrow 1 and pivot it out, arrow 2.

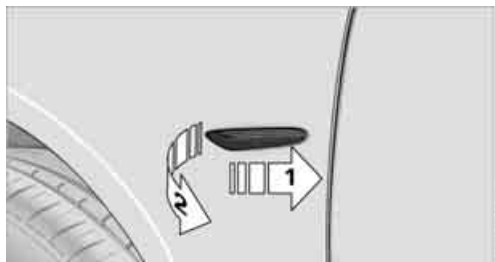

2. While simultaneously lifting the retaining tab, rotate bulb holder to the left and remove.
3. Remove lamp and replace it.

To install, insert rear end of the lamp and press into place at the front.

Tail lamps

Coupe: overview

The tail lamps are divided in two parts. One part is in the trunk lid, the other is in the fender.

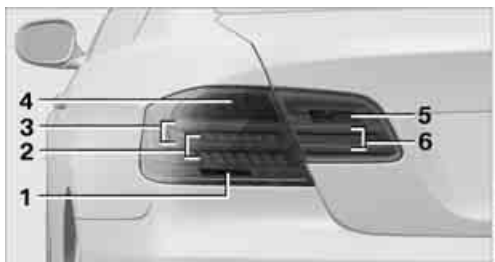

- 1 Backup lamp
- 2 Brake lamp
- 3 Parking/tail lamps
- 4 Turn signal
- 5 Brake Force Display lamp
- 6 Parking/tail lamps

Convertible: overview

The tail lamps are divided in two parts. One part is in the trunk lid, the other is in the fender.

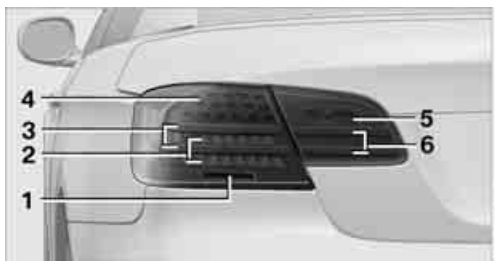

- 1 Backup lamp
- 2 Brake lamp
- 3 Parking/tail lamps
- 4 Turn signal
- 5 Brake Force Display lamp
- 6 Parking/tail lamps

Backup lamp

If these lamps malfunction, please contact your BMW center.

Turn signal, brake, license plate, parking, and tail lamps

These lamps use LED technology for operation. If they malfunction, please contact your BMW center.

Coupe: Brake Force Display lamp in the trunk lid

H21W bulb, 21 watts

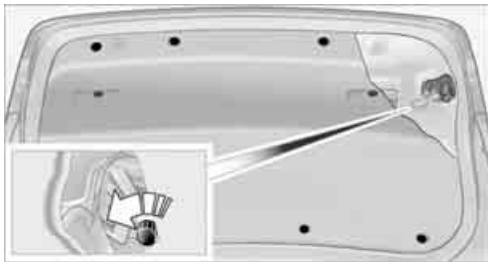

1. Pry out the plastic plugs in the trim of the trunk lid using a screwdriver and remove the trim.
2. Release the bulb holder, see arrow, and remove.
3. Apply gentle pressure to the bulb while turning it to the left for removal and replacement.
4. Attach the bulb holder.
5. Attach trunk lid trim.

Convertible: Brake Force Display lamp in the trunk lid

H21W bulb, 21 watts

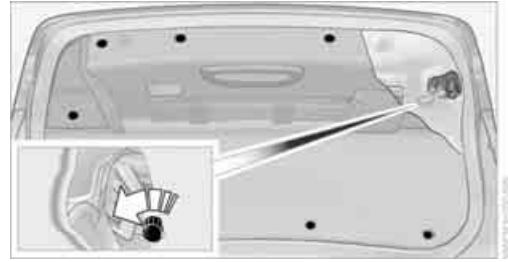

1. Take the warning triangle out of its holder, refer to page 215. Unscrew the holder using the screwdriver from the onboard vehicle tool kit.
2. Pry out the plastic plugs in the trim of the trunk lid using a screwdriver and remove the trim.
3. Release the bulb holder, see arrow, and remove.
4. Apply gentle pressure to the bulb while turning it to the left for removal and replacement.
5. Attach the bulb holder.
6. Reattach the trim of the trunk lid and the holder for the warning triangle.

Changing wheels

Your BMW is equipped with run-flat tires as standard. This eliminates the need to change a wheel immediately in the event of a puncture.

For information on continuing to drive with a damaged tire, refer to Indication of a flat tire on page 94.

The symbol identifying run-flat tires is a circle with the letters RSC on the sidewall, refer to Run-flat tires, page 195.

When mounting new tires or changing over from summer to winter tires and vice versa, mount run-flat tires for your own safety. In the event of a flat, no spare wheel is available. Your BMW center will be glad to advise you. Refer also to New wheels and tires, page 195.

 The tools for changing wheels are available as optional accessories from your BMW center. ◀

Jack mounting points

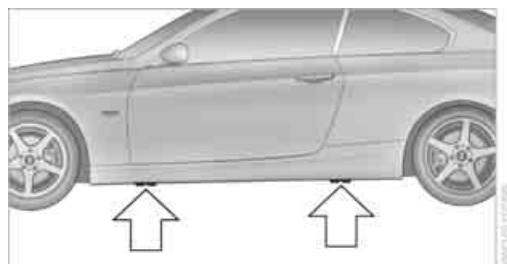

The jacking points are at the positions shown in the illustration.

Vehicle battery

Battery care

The battery is 100% maintenance-free, the electrolyte will last for the life of the battery when the vehicle is operated in a temperate climate. Your BMW center will be glad to advise in all matters concerning the battery.

Battery replacing

 Only use vehicle batteries that have been approved for your vehicle by the manufacturer; otherwise, the vehicle could be damaged and systems or functions may not be fully available. ◀

After a battery replacement, have the battery registered on the vehicle by your service center to ensure that all comfort functions are fully available.

Charging the battery

Note

 Do not connect battery chargers to the sockets built into the vehicle at the plant; doing so may damage the vehicle. ◀

Jump-starting terminals

Only charge the battery in the vehicle via the terminals in the engine compartment with the engine off. Connections, refer to Jump-starting on page 216.

Power failure

After a temporary power loss, the functioning of some equipment may be limited and require reinitialization. Individual settings may likewise have been lost and will have to be programmed:

- ▷ Time and date
These values must be updated, refer to page 86.
- ▷ Radio
In some cases, stations may have to be stored again, refer to page 144.
- ▷ Glass roof
It may happen that the roof can only be tilted. The system must be initialized. Please contact your BMW center.
- ▷ Seat and mirror memory
The positions must be stored again, refer to page 48.
- ▷ Inside rearview mirror with digital compass
The system must be calibrated, refer to page 119.
- ▷ Active steering
The system automatically initializes itself briefly during a trip. The system is deactivated during this time, refer to page 97.
- ▷ xDrive
The system automatically initializes itself during a trip. Indicator lamps light up during this time. If the lamps do not go out during the current trip, have the system checked.

Disposal of old battery



Have old batteries disposed of by your BMW center or bring them to a collection point. Maintain the battery in an upright position for transport and storage. Always secure the battery against tipping over during transport. ◀

Fuses



Never attempt to repair a blown fuse and do not replace a defective fuse with a substitute of another color or amperage rating; otherwise, this could lead to a circuit overload, ultimately resulting in a fire in the vehicle. ◀

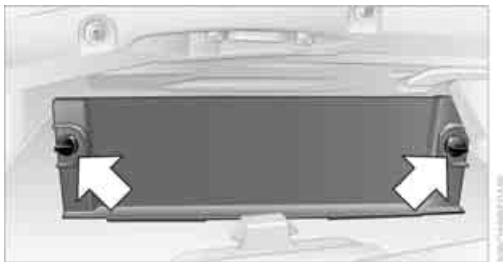

Open the cover in the glove compartment and remove it.

Plastic tweezers are located on the distributor box.

See the rear of the cover for information on fuse assignment.

Spare fuses are available at your BMW center.

Giving and receiving assistance

Vehicle equipment

In this chapter, all production, country, and optional equipment that is offered in the model range is described. For this reason, descriptions will be given of some equipment that may not be available in a vehicle, for example due to the special options or national-market version selected. This also applies to safety related functions and systems.

Emergency Request

Requirements

- ▷ Full preparation package mobile phone: this equipment makes it possible to send an Emergency Request even if no mobile phone is paired with the vehicle.
- ▷ BMW Assist is activated.
- ▷ Radio readiness is switched on.
- ▷ The BMW Assist system is logged into a mobile phone network that is supported by BMW Assist.
- ▷ The Emergency Request system is operable.

Only press the SOS button in an emergency.



For technical reasons, the Emergency Request service cannot be guaranteed for the most unfavorable conditions. ◀

Subscriber contract

Upon expiration of the subscriber contract with BMW Assist, the BMW Assist system can be deactivated by a BMW center without a workshop visit.

After the system is deactivated, it is no longer possible to make Emergency Requests.

It may be possible for a BMW center to reactivate the system after a new contract has been signed.

Sending an Emergency Request

1. Briefly press the cover flap to open.



2. Press the SOS button until the LED in the button comes on.
- ▷ The LED comes on: the Emergency Request has been triggered.

If the circumstances allow, remain in the vehicle until the voice contact has been established.

- ▷ The LED flashes when the connection to the BMW Assist Response Center has been established.

Once the BMW Assist Response Center has received your Emergency Request, the BMW Assist Response Center contacts you and takes further steps to help you. Even if you are unable to respond, the BMW Assist Response Center will be able to initiate further steps to assist you under certain conditions.

Data for determining the necessary rescue measures are transmitted to the BMW Assist Response Center, e.g. the current position of your vehicle, if it can be determined.

- ▷ If the LED is flashing but the BMW Assist Response Center cannot be heard over the hands-free system, it is possible that the hands-free system is malfunctioning. The BMW Assist Response Center may still be able to hear you, however.

Automatically triggering an Emergency Request

Under certain conditions, an Emergency Request is sent automatically immediately after a severe accident. An automatic Emergency Request is not affected by pressing the SOS button.

Roadside Assistance

BMW Roadside Assistance is available by phone around the clock in many countries. You can obtain support there in the event of a breakdown.

First aid pouch

Some of the articles contained in the first aid pouch have a limited service life. Therefore, check the expiration dates of the contents regularly and replace any items in good time, if necessary.

Coupe



The first aid pouch is located on the right-hand side of the cargo area in a storage area.

Convertible



The first aid pouch is located in a compartment under the front passenger seat.

To open: press the button and fold the cover down.

To close: fold the cover back up and press it into the catch.

Warning triangle

Coupe

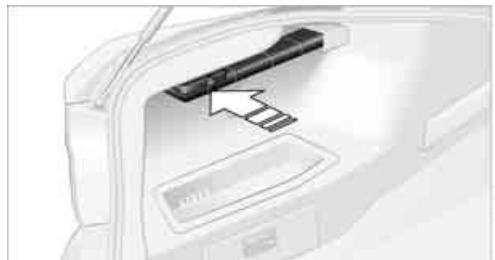

The warning triangle is located on the left-hand side of the cargo area. Press the tab to take it out.

Convertible

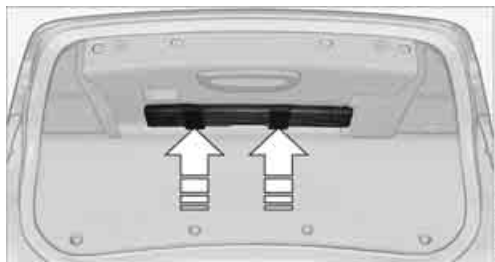

The warning triangle is located in a holder in the trunk lid. Press the tabs to take it out.

Jump-starting

If the car's own battery is flat, your BMW's engine can be started by connecting two jumper cables to another vehicle's battery. You can also use the same method to help start another vehicle. Only use jumper cables with fully-insulated clamp handles.

 Do not touch any electrically live parts when the engine is running, or a fatal accident may occur. Carefully adhere to the following sequence, both to prevent damage to one or both vehicles, and to guard against possible personal injuries. ◀

Preparation

1. Check whether the battery of the other vehicle has a voltage of 12 volts and approximately the same capacitance in Ah. This information can be found on the battery.
2. Switch off the engine of the assisting vehicle.
3. Switch off any consumers in both vehicles.

 There must not be any contact between the bodies of the two vehicles; otherwise, there is a danger of shorting. ◀

Connecting jumper cables

 Connect the jumper cables in the correct order, so that no sparks which could cause injury occur. ◀

Your BMW has a jump-starting connection in the engine compartment which acts as the battery's positive terminal, refer also to the Engine compartment overview on page 197. The cap is marked with +.

1. Pull the cap of the BMW jump-starting connection up to remove.



2. Attach one terminal clamp of the plus/+ jumper cable to the positive terminal of the battery or a starting-aid terminal of the vehicle providing assistance.
3. Attach the second terminal clamp of the plus/+ jumper cable to the positive terminal of the battery or a starting-aid terminal of the vehicle to be started.
4. Attach one terminal clamp of the minus/- jumper cable to the negative terminal of the battery or to an engine or body ground of the assisting vehicle.
Your BMW has a special nut as body ground or negative pole.



- Attach the second terminal clamp of the minus/- jumper cable to the negative terminal of the battery or to the engine or body ground of the vehicle to be started.

Starting the engine

- Start the engine of the donor vehicle and allow it to run for a few minutes at slightly increased idle speed.
- Start the engine on the other vehicle in the usual way.
If the first start attempt is not successful, wait a few minutes before another attempt in order to allow the discharged battery to recharge.
- Let the engines run for a few minutes.
- Disconnect the jumper cables by reversing the above connecting sequence.

If necessary, have the battery checked and recharged.

-  Never use spray fluids to start the engine. ◀

Tow-starting, towing away

 Observe the applicable laws and regulations for tow-starting and towing vehicles. ◀

 Do not transport any passengers other than the driver in a vehicle that is being towed. ◀

Using a tow fitting

The screw-in tow fitting must always be carried in the car. It can be screwed in at the front or rear of the BMW.

Coupe: it is stored in the onboard vehicle tool kit underneath the cover on the right-hand side of the cargo area, refer to page 208.

Convertible: it is stored in the onboard vehicle tool kit underneath the cargo area floor, refer to page 208.

 Use only the tow fitting provided with the vehicle and screw it all the way in. Use the tow fitting for towing on paved roads only. Avoid lateral loading of the tow fitting, e.g. do not lift the vehicle by the tow fitting. Otherwise, the tow fitting and the vehicle could be damaged. ◀

Access to screw thread

Release the cover panel in the bumper:
Press on the upper part of the cover panel.

Front

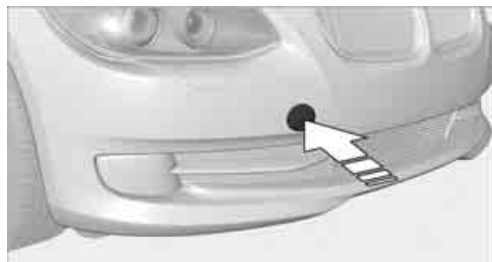

Rear

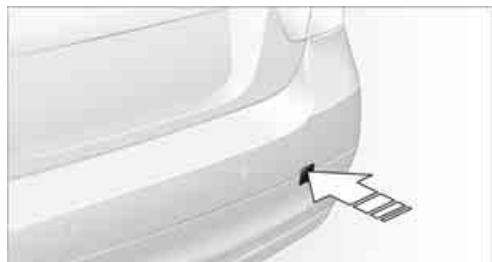

Being towed

 Make sure that the ignition is switched on, refer to page 57; otherwise, the low-beam headlamps, tail lamps, turn signal indicators and windshield wipers may be unavailable.

Power steering assistance is not available when the engine is not running. Thus, braking and steering will require increased effort. Active steering is not active and it will be necessary to turn the steering wheel further. ◀

Manual transmission

Gearshift lever in neutral position.

Automatic transmission

Selector lever in position N.

Changing selector lever positions, refer to page 60.

 Do not exceed a towing speed of 45 mph or 70 km/h and a towing distance of 90 miles/150 km; otherwise, the automatic transmission may be damaged. ◀

Sport automatic transmission with double clutch

 Make sure that the parking lock P is not engaged; otherwise, the rear wheels are immobilized.

When using the car wash function, refer to page 205, note that the parking lock P is engaged automatically after approx. 30 minutes, blocking the rear wheels.

In the event of an electrical malfunction or if the vehicle must be towed for more than approx. 20 minutes, unlock the parking lock manually, refer to page 65. ◀

 When towing, do not exceed a maximum speed of 30 mph or 50 km/h and a maximum distance traveled of 30 miles/50 km; otherwise, the transmission may be damaged. ◀

Towing methods

 Do not lift the vehicle by a tow fitting or body and chassis parts; otherwise, damage may result. ◀

With a tow bar

 The towing vehicle must not be lighter than the towed vehicle; otherwise, it may be impossible to maintain control. ◀

The tow fittings used should be on the same side on both vehicles. Should it prove impossible to avoid mounting the tow bar at an angle, please observe the following:

- ▷ Clearance and maneuvering capability will be sharply limited during cornering.
- ▷ The tow bar will generate lateral forces if it is attached offset.

 Attach the tow bar to the tow fittings only, as attaching it to other parts of the vehicle could result in damage. ◀

With a tow rope

When starting off in the towing vehicle, make sure that the tow rope is taut.

 To avoid jerking and the associated stresses on vehicle components when towing, always use nylon ropes or nylon straps. Attach the tow rope to the tow fittings only, as attaching it to other parts of the vehicle could result in damage. ◀

With a tow truck: vehicle without xDrive

Manual and automatic transmission:

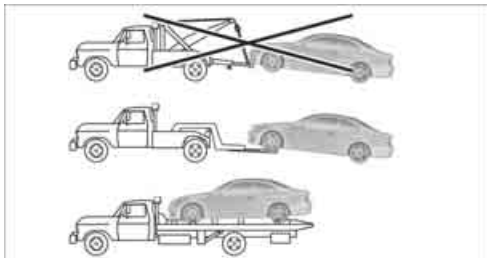

Sport automatic transmission with double clutch:

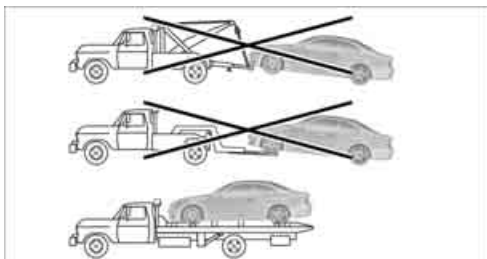

Have the BMW transported with a tow truck with a so-called lift bar, or on a flatbed.

Do not tow the vehicle with just the rear axle raised as this may cause the steering to turn.

With a tow truck: vehicle with xDrive



Do not tow a BMW with xDrive with just the front or rear axle raised; otherwise, the wheels could lock up and the transfer case could be damaged. ◀

Have the BMW transported on a flatbed surface only.

Tow-starting

Avoid tow-starting the vehicle whenever possible; instead, jump-start the engine, refer to page 216. Vehicles with a catalytic converter should only be tow-started when the engine is cold; vehicles with an automatic transmission or Sport automatic transmission with double clutch cannot be tow-started at all.

1. Switch on hazard warning flashers, comply with local regulations.
2. Switch on the ignition, refer to page 57.
3. Shift into 3rd gear.
4. Have the vehicle tow-started with the clutch depressed and slowly release the clutch. After the engine starts, immediately depress the clutch completely again.
5. Stop at a suitable location, remove the tow bar or rope and switch off the hazard warning flashers.
6. Have the vehicle checked.



With xDrive: do not activate Hill Descent Control HDC when the vehicle is being tow-started, page 92. ◀

Indicator and warning lamps

Vehicle equipment









In this chapter, all production, country, and optional equipment that is offered in the model range is described. For this reason, descriptions will be given of some equipment that may not be available in a vehicle, for example due to the special options or national-market version selected. This also applies to safety related functions and systems.









The concept















Indicator and warning lamps can light up in a variety of combinations and colors. See the table for information on causes and how to react. Note whether a lamp lights up alone or in combination with another. Some lamps can light up in different colors. Corresponding distinctions are made in the text.













1	2	Cause	What to do
		Turn signals	
		High beams/headlamp flasher switched on	
		Fog lamps switched on	
		Fasten safety belts	Fasten your safety belt, also refer to page 49.
		Indication in US models Parking brake applied while driving	Release the parking brake.
		Indication in Canadian models Parking brake applied while driving	Release the parking brake.
		Outside temperature warning	Drive cautiously, also refer to page 78.

















1	2	Cause	What to do
		<p>Lights up briefly: Approx. 2.1 US gal/8 liters of fuel remain in the tank</p> <p>Remains on: Remaining operating range is no more than 30 miles/50 km, refer to page 79</p>	
		Engine refuses to start	Depress the brake or clutch in order to start the engine, refer to page 58.
		<p>Ignition switched on and driver's door open</p> <p>The desired function cannot currently be carried out</p>	Switch off the ignition, refer to page 57, or close the driver's door.
		Parking lamps still on	Switch off the parking lamps, refer to page 103.
		Roadside parking lamps still on	Switch off the roadside parking lamps, refer to page 105.
		Door open	
		Engine compartment lid open	
		<p>Lights up in red: Backrest of driver's seat or front passenger seat not locked</p> <p>Lights up in yellow: Seat backrest monitor malfunctioning</p>	<p>Lock the backrest; otherwise, the safety belt will not provide protection in the event of an accident.</p> <p>Engage the seat backrest. Have it checked by your nearest BMW center.</p>



















1	2	Cause	What to do
	<p>Lights up in red: Roof activation system failure</p> <p>Roof activation system malfunctioning</p> <p>Lights up in yellow: Roof drive overheated</p> <p>Cargo area partition not in lowermost position</p>		<p>Roof cannot be moved. If the retractable hardtop does not lock, contact your nearest BMW center.</p> <p>Roof movement incomplete. Please check if the roof is blocked, then press or pull the switch again.</p> <p>Roof activation temporarily limited to closing only.</p> <p>Press down the cargo area partition until it engages on both sides.</p>
	Vehicle not level, roof activation not possible		Move the vehicle to a level surface.
	Rollover protection system malfunctioning		Have the rollover protection system checked by the nearest BMW center.
	Trunk lid open		
	Fuel cap is open		Make sure that the fuel cap is correctly positioned and close it until it audibly clicks. Do not jam the strap between the fuel cap and the vehicle.
	Windshield washer fluid level too low		Add washer fluid as soon as possible, refer to page 69.
	<p>Lights up in red: Service due</p> <p>Lights up in yellow: The engine will start the next time the Start/Stop button is briefly pressed, possibly without the brake or clutch being depressed</p>		<p>Arrange a service appointment. Check service requirements, refer to page 84.</p>
	Remote control malfunctioning or, in cars with Comfort Access, not detected		The engine cannot be started. Have the remote control checked, if necessary.
	Battery in remote control discharged		Use the remote control for a longer journey or, in cars with Comfort Access, replace the battery.









1	2	Cause	What to do
		Belt tensioners and/or airbag system failed	Have the system checked immediately.
		Active steering defective	You can continue your journey. Steering characteristics are modified and steering wheel could be off-center. Steer carefully. Have the system checked as soon as possible.
		Steering assistance failed	Markedly different steering response. You can continue your journey, but moderate your speed and exercise due caution. Have the system checked as soon as possible.
		Lights up: Emergency Request system has failed or is malfunctioning	Have the system checked as soon as possible.
		Lights up in red: Engine malfunction	Stop the car and switch off the engine. You cannot continue your journey. Contact your BMW center.
		Lights up in yellow: Full engine power is no longer available	You can continue your journey, but moderate your speed and exercise due caution. Have the engine checked as soon as possible.
		Indication in US models: Warning lamp flashes: Engine malfunction under high load. High engine load will result in damage to the catalytic converter	You can continue your journey, but moderate your speed and exercise due caution. Have the vehicle checked without delay.
		Warning lamp lights up: Engine malfunction with adverse effect on emissions	Have the car checked as soon as possible.



1	2	Cause	What to do
	<p>Indication in Canadian models:</p> <p>Warning lamp flashes:</p> <p>Engine malfunction under high load. High engine load will result in damage to the catalytic converter</p> <p>Warning lamp lights up:</p> <p>Engine malfunction with adverse effect on emissions</p>	<p>You can continue your journey, but moderate your speed and exercise due caution. Have the vehicle checked without delay.</p> <p>Have the car checked as soon as possible.</p>	
	<p>Lights up in red:</p> <p>Engine overheating</p> <p>Lights up in yellow:</p> <p>Engine too hot</p>	<p>Carefully bring the car to a stop, switch off the engine and allow it to cool down. Do not open the hood; otherwise, there is a risk of injury from scalding. Contact your BMW center.</p> <p>Continue driving at more moderate speed so that the engine can cool down. Have the engine checked without delay if the situation reoccurs.</p>	
	<p>Lights up in red:</p> <p>Battery is no longer being charged. Alternator malfunction</p> <p>Lights up in yellow:</p> <p>Battery charge level very low, battery aged or not securely connected</p>	<p>Switch off all unnecessary electrical consumers. Have the power supply system checked without delay.</p> <p>Have the battery checked as soon as possible.</p>	
BRAKE	<p>Indication in US models</p> <p>Parking brake applied</p>		
	<p>Indication in Canadian models</p> <p>Parking brake applied</p>		
BRAKE	<p>Indication in US models</p> <p>Lights up in red:</p> <p>Brake fluid level too low</p>	<p>Braking action is reduced, stop with care. Contact your BMW center.</p>	









1	2	Cause	What to do
		Indication in Canadian models Lights up in red: Brake fluid level too low	Braking action is reduced, stop with care. Contact your BMW center.
BRAKE		Indication in US models Brake pads worn	Have the condition of the brake pads checked without delay.
		Indication in Canadian models Brake pads worn	Have the condition of the brake pads checked without delay.
		Lights up in red: <ul style="list-style-type: none">▷ Starter failed or▷ Ignition malfunctioning. Engine restart only possible when brake is depressed or▷ Lighting system failed. Low beams/ tail lamps and brake lamps still operational. All other lamps failed Lights up in yellow: <ul style="list-style-type: none">▷ Control of the brake lamps failed or▷ Fuel supply malfunctioning/Drive unit malfunction	Have the system in question checked without delay. The engine cannot be restarted. Depress the brake to restart the engine.
		Flashing: Dynamic Stability Control DSC or Dynamic Traction Control DTC is controlling drive and braking forces, also refer to page 91	
		Dynamic Traction Control DTC activated, also refer to page 91	
		Dynamic Stability Control DSC and Dynamic Traction Control DTC deactivated, also refer to page 91	Driving stability limited during acceleration and cornering. Driving style must be readjusted.
		Suspension control system failed, also refer to page 90	Driving stability limited during acceleration and cornering. You can continue your journey, but moderate your speed and exercise due caution. Have the system checked as soon as possible.













1	2	Cause	What to do
		xDrive has failed, also refer to page 92	You can continue your journey. Drive cautiously and think well ahead. Avoid driving on rough tracks, full-throttle operation and use of the transmission's kickdown mode. Have the system checked immediately.
		xDrive and DSC have failed, also refer to page 92	You can continue your journey. Drive cautiously and think well ahead. Avoid driving on rough tracks, full-throttle operation and use of the transmission's kickdown mode. Have the system checked immediately.
ABS		Indication in US models The driving stability control systems, including ABS and the Tire Pressure Monitor, have failed, also refer to page 90	You can continue your journey. Reduced braking and driving stability. Drive at moderate speeds, avoiding abrupt braking maneuvers. Have the system checked as soon as possible.
BRAKE			
			
			
(ABS)		Indication in Canadian models The driving stability control systems, including ABS and the Flat Tire Monitor, or Tire Pressure Monitor have failed, also refer to page 90	You can continue your journey. Reduced braking and driving stability. Drive at moderate speeds, avoiding abrupt braking maneuvers. Have the system checked as soon as possible.
(!)			
			
			
ABS		Indication in Canadian models The driving stability control systems, including ABS and the Flat Tire Monitor, or Tire Pressure Monitor have failed, also refer to page 90	You can continue your journey. Reduced braking and driving stability. Drive at moderate speeds, avoiding abrupt braking maneuvers. Have the system checked as soon as possible.
(!)			
			
			
ABS		Indication in US models The driving stability control systems, including ABS, xDrive and the Flat Tire Monitor, have failed	You can continue your journey. Reduced braking and driving stability. Drive at moderate speeds, avoiding abrupt braking maneuvers. Avoid driving on rough tracks, full-throttle operation and use of the transmission's kickdown mode. Have the system checked immediately.
BRAKE			
			
			

1	2	Cause	What to do
   		<p>Indication in Canadian models</p> <p>The driving stability control systems, including ABS, xDrive and the Flat Tire Monitor, have failed</p>	<p>You can continue your journey. Reduced braking and driving stability. Drive at moderate speeds, avoiding abrupt braking maneuvers. Avoid driving on rough tracks, full-throttle operation and use of the transmission's kick-down mode. Have the system checked immediately.</p>
<p>ABS</p>   		<p>Indication in Canadian models</p> <p>The driving stability control systems, including ABS, xDrive and the Flat Tire Monitor, have failed</p>	<p>You can continue your journey. Reduced braking and driving stability. Drive at moderate speeds, avoiding abrupt braking maneuvers. Avoid driving on rough tracks, full-throttle operation and use of the transmission's kick-down mode. Have the system checked immediately.</p>
<p>ABS</p> <p>BRAKE</p> 		<p>Indication in US models</p> <p>Vehicle electronics failed</p>	<p>You cannot continue your journey. Contact your BMW center.</p>
  		<p>Indication in Canadian models</p> <p>Vehicle electronics failed</p>	<p>You cannot continue your journey. Contact your BMW center.</p>
<p>ABS</p>  		<p>Indication in Canadian models</p> <p>Vehicle electronics failed</p>	<p>You cannot continue your journey. Contact your BMW center.</p>

1	2	Cause	What to do
		<p>Vehicles with Flat Tire Monitor</p> <p>Light up in yellow and red:</p> <ul style="list-style-type: none"> ▷ Tire is deflated ▷ Flat Tire Monitor not initialized <p>Light up in yellow:</p> <p>Flat Tire Monitor failed. Punctures are not indicated</p>	<p>Carefully bring the car to a stop. Comply with the additional information starting on page 93.</p> <p>Initialize Flat Tire Monitor, refer to page 93.</p> <p>Have the system checked.</p>
		<p>Vehicles with Tire Pressure Monitor</p> <p>Light up in yellow and red:</p> <p>There is a flat tire or substantial loss of tire pressure in the indicated wheel</p>	<p>Carefully bring the car to a stop. Comply with the additional information starting on page 95.</p>
		<p>Vehicles with Tire Pressure Monitor</p> <p>Light up in yellow:</p> <ul style="list-style-type: none"> ▷ Tire Pressure Monitor not initialized <p>The small lamp flashes in yellow and then lights up continuously; the larger lamp lights up in yellow:</p> <ul style="list-style-type: none"> ▷ Tire Pressure Monitor has failed. Punctures are not indicated ▷ Interference from systems or devices that use the same radio frequency. The system automatically reactivates once it is outside of the field of interference 	<p>Check the inflation pressure and reset the system, refer to page 95</p> <p>Have the system checked.</p>
		<p>Vehicles with Tire Pressure Monitor:</p> <p>The small lamp flashes in yellow and then lights up continuously; the larger lamp lights up in yellow:</p> <ul style="list-style-type: none"> ▷ Tire Pressure Monitor has failed. Punctures are not indicated ▷ A wheel without TPM electronics has been mounted 	<p>Have the system checked.</p>

1	2	Cause	What to do
	 <p>Lights up in red:</p> <ul style="list-style-type: none"> ▷ Transmission limp-home program active with restricted range of gears, possibly with reduced acceleration ▷ Gears can be engaged without depressing the brake <p>Lights up in yellow:</p> <ul style="list-style-type: none"> ▷ Transmission limp-home program active with restricted range of gears ▷ Automatic selector lever locked: Selector lever locked in position P with engine running or ignition switched on and brake depressed ▷ Selector lever position P malfunctioning: Selector lever locked in position P with engine running or ignition switched on and brake depressed ▷ Brake signal malfunctioning: gear can be engaged without depressing the brake 		<p>You can continue your journey, but moderate your speed and exercise due caution. Have the system checked without delay.</p> <p>Always depress the brake to engage a gear.</p> <p>You can continue your journey, but moderate your speed and exercise due caution. Have the system checked without delay.</p> <p>Overriding selector lever lock, refer to page 62.</p> <p>Release parking lock, refer to page 65. Have the system checked as soon as possible.</p> <p>To engage a gear while the vehicle is at a standstill, always step on the brake. Before leaving the vehicle, engage P and switch off the engine.</p>
	 <p>Lights up in red:</p> <p>Transmission overheating</p> <p>Lights up in yellow:</p> <p>Transmission too hot</p>		<p>Bring the car to a stop and engage P. Allow the transmission to cool down. You can continue your journey, but moderate your speed and exercise due caution. Have the system checked if the situation reoccurs.</p> <p>Avoid high engine loads. You can continue your journey, but moderate your speed and exercise due caution.</p>
	 <p>P is not engaged. Vehicle not prevented from rolling</p>		

1	2	Cause	What to do
		Selector lever position P not engaged. Ignition cannot be switched off	Engage selector lever position P when you wish to switch off the ignition, refer to page 57.
		Selector lever malfunctioning	You can continue your journey. Shift again if necessary. Have the system checked if the situation reoccurs.
		Brake signal malfunctioning: gear can be engaged without depressing the brake	To engage a gear while the vehicle is at a standstill, always step on the brake. Switch off the engine before leaving the vehicle. Have the system checked as soon as possible.
		Pinch protection system of the power windows malfunctioning	Have the system checked.
		Pinch protection system of the electric glass roof malfunctioning	Have the system checked.
		Cruise control deactivated: <ul style="list-style-type: none"> ▷ Driving stability control systems are active or ▷ parking brake is applied or ▷ the vehicle has not achieved a speed of 20 mph or 30 km/h or ▷ engaged gear is not suitable for the speed being driven 	
		Cruise control system failed	You can continue your journey. Have the system checked.
		Active Cruise Control deactivated: <ul style="list-style-type: none"> ▷ Driving stability control systems are active or ▷ parking brake is applied or ▷ the vehicle has not achieved a speed of 20 mph or 30 km/h or ▷ engaged gear is not suitable for the speed being driven or ▷ Radar sensor dirty 	Keep a safe distance.
		Active Cruise Control failed	Clean the radar sensor, refer to page 75. Have the system checked.

1	2	Cause	What to do
		Park Distance Control failed	Have the system checked.
	▷	High-beam Assistant inactive	Clean the sensor field on the front of the interior rearview mirror, refer to page 106.
	▷	High-beam Assistant malfunctioning	Have the system checked by the nearest BMW center.
	▷	Sensitivity of the High-beam Assistant has been changed	There is a risk that oncoming traffic may be blinded. Have the system checked by the nearest BMW center.
		Bulb of exterior lighting system failed	Have the exterior lighting checked as soon as possible.
		Low-beam headlamp or fog lamp failed	Have the low beams checked as soon as possible.
		High-beam headlamp failed	Have the high-beam headlamps checked.
		Adaptive Light Control failed	
		Coolant level too low	Add coolant immediately, refer to page 200.
		Engine oil pressure too low	Stop immediately and switch off the engine. You cannot continue your journey. Contact your BMW center.
		Engine oil level too low	Add engine oil immediately; refer to page 198 for more information.
		Lights up in red: Service appointment overdue	Arrange a service appointment. Check service requirements, refer to page 84.
		Lights up in yellow: Service due	Arrange a service appointment. Check service requirements, refer to page 84.
		No service due	Check service requirements, refer to page 84.
		Time and date no longer correct	Set the time and date, refer to page 86.



Reference

This chapter contains technical data and an index that will help you find information most quickly.

Technical data

Vehicle equipment

In this chapter, all production, country, and optional equipment that is offered in the model range is described. As a result, some equipment described may not be available in a partic-

ular vehicle, for example due to the options or national-market version selected. This also applies to safety related functions and systems.

Engine data

Coupe

		328i/xDrive	335i/xDrive	335is
Displacement	cu in/cm ³	182.8/2,996	181.8/2,979	181.8/2,979
Number of cylinders		6	6	6
Maximum power output	hp	230	300	320
at engine speed	rpm	6,500	5,800	5,900
Maximum torque	lb ft/Nm	200/270	300/407	332/450
with Overboost	lb ft/Nm	–	–	369/500
at engine speed	rpm	2,750	1,300-5,000	1,500

Convertible

		328i	335i	335is
Displacement	cu in/cm ³	182.8/2,996	181.8/2,979	181.8/2,979
Number of cylinders		6	6	6
Maximum power output	hp	230	300	320
at engine speed	rpm	6,500	5,800	5,900
Maximum torque	lb ft/Nm	200/270	300/407	332/450
with Overboost	lb ft/Nm	–	–	369/500
at engine speed	rpm	2,750	1,300-5,000	1,500

Dimensions

Coupe

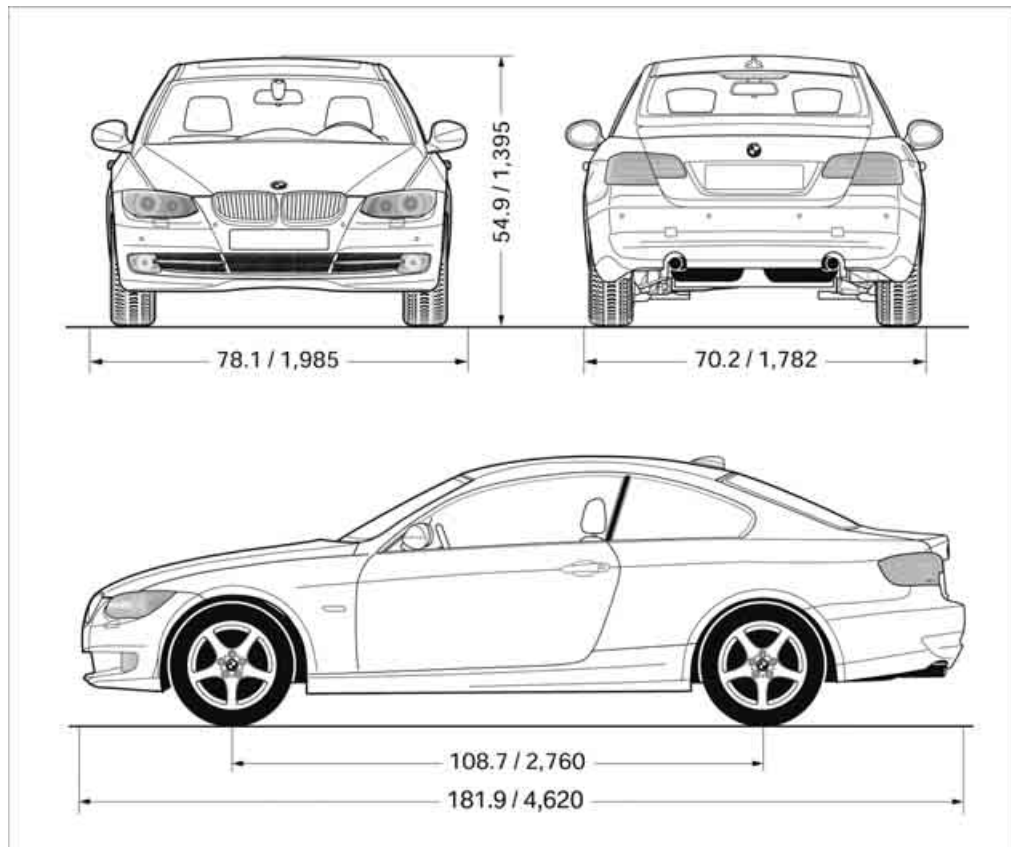

All dimensions given in inches/mm.

Smallest turning circle dia.: 36.1 ft/11.0 m, with xDrive: 38.7 ft/11.8 m

335i: height approx. 54.1 in/1,375 mm

Convertible

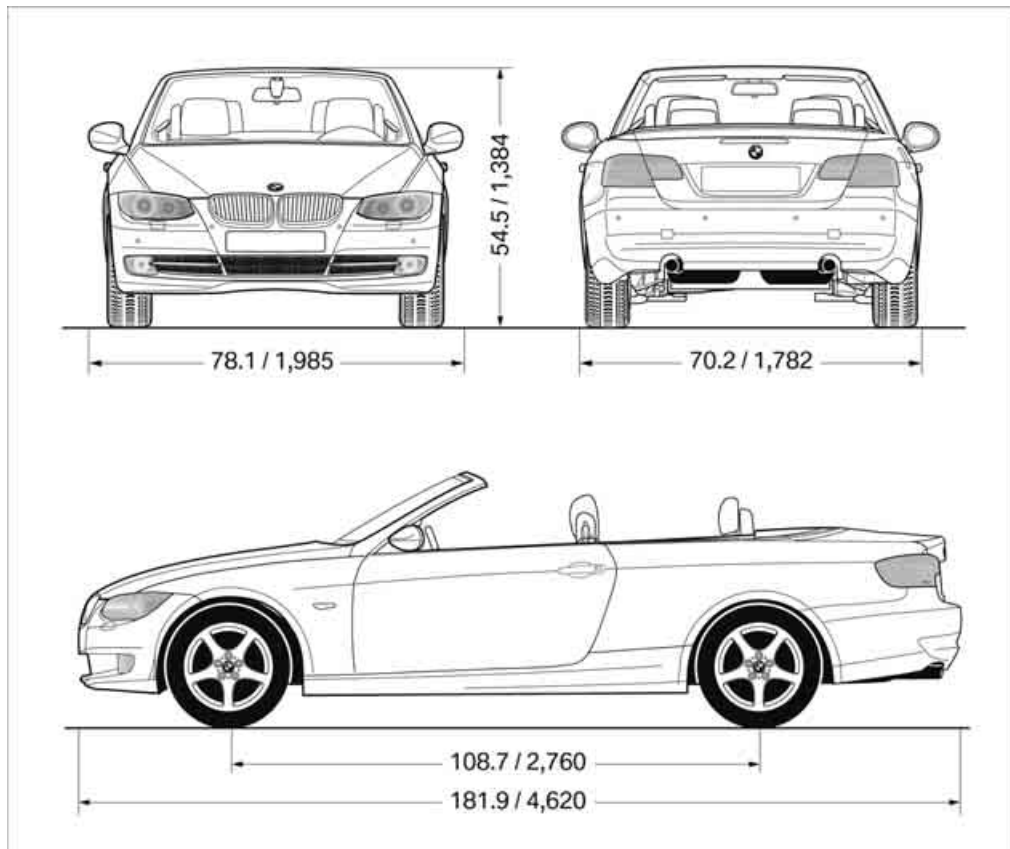

All dimensions given in inches/mm.

Smallest turning circle dia.: 36.1 ft/11.0 m

335i: height approx. 54.0 in/1,370 mm

Weights

Coupe

		328i	328i xDrive	335i	335i xDrive
Approved gross weight					
▷ with manual transmission	lbs./kg	4,288/1,945	4,508/2,045	4,486/2,035	4,663/2,115
▷ with automatic transmission	lbs./kg	4,354/1,975	4,552/2,065	4,508/2,045	4,685/2,125
Load	lbs./kg	882/400	882/400	882/400	882/400
Approved front axle load	lbs./kg	2,061/935	2,227/1,010	2,172/985	2,326/1,055
Approved rear axle load	lbs./kg	2,425/1,100	2,447/1,110	2,469/1,120	2,513/1,140
Approved roof load capacity	lbs./kg	165/75	165/75	165/75	165/75
Cargo area capacity	cu ft/ liters	15.5/440	15.5/440	15.2/430	15.2/430

		335is			
Approved gross weight					
▷ with manual transmission	lbs./kg	4,497/2,040			
▷ Sport automatic transmission with double clutch	lbs./kg	4,519/2,050			
Load	lbs./kg	882/400			
Approved front axle load	lbs./kg	2,183/990			
Approved rear axle load	lbs./kg	2,513/1,140			
Approved roof load capacity	lbs./kg	165/75			
Cargo area capacity	cu ft/ liters	15.2/430			

Convertible

		328i	335i	335is
Approved gross weight				
▷ with manual transmission	lbs./kg	4,707/2,135	4,817/2,185	4,839/2,195
▷ with automatic transmission	lbs./kg	4,773/2,165	4,839/2,195	–
▷ Sport automatic transmission with double clutch	lbs./kg	–	–	4,872/2,210
Load	lbs./kg	838/380	838/380	838/380
Approved front axle load	lbs./kg	2,138/970	2,205/1,000	2,227/1,010
Approved rear axle load	lbs./kg	2,646/1,200	2,646/1,200	2,646/1,200
Approved roof load capacity	lbs./kg	–	–	–
Cargo area capacity	cu ft/	7.4-12.4/	7.4-12.4/	7.4-12.4/
	liters	210-350	210-350	210-350

Capacities

			Notes
Fuel tank	US gal/liters	approx. 16.1/61	Fuel grade: page 175
including reserve of	US gal/liters	approx. 2.1/8.0	
Window washer system			For more details: page 69
including headlamp washers	US quarts/liters	approx. 6.3/6.0	

Everything from A to Z

Index

A

- ABS Antilock Brake System **90**
- ACC, refer to Active Cruise Control **71**
- Acceleration assistant, refer to Launch Control **66**
- Accessories, refer to Vehicle equipment **5**
- Accident, refer to Sending an Emergency Request **214**
- Activated-charcoal filter for automatic climate control **115**
- Active Cruise Control **71**
 - indicator lamp **74**
 - malfunction **75**
 - selecting distance **73**
 - sensor **75**
- Active steering **97**
- Adaptive brake lamp
 - Brake Force Display **98**
- Adaptive Light Control **105**
- Additives
 - coolant **200**
 - engine oil **200**
- Adjusting temperature inside the car, refer to Air conditioner **110**
- Adjusting temperature inside the car, refer to Automatic climate control **112**
- Adjusting the thigh support **44**
- Airbags **99**
 - indicator/warning lamp **101**
 - sitting safely **42**
- Air conditioner **109**
 - Air conditioning mode
 - air conditioner **110**
 - automatic climate control **112**
 - ventilation **111, 114**
 - Air distribution
 - automatic **113**
 - individual **110**
 - manual **110**
 - Airing, refer to Ventilation **111, 114**
 - Air outlets, refer to Air vents **110**
 - Air pressure, refer to Tire inflation pressure **177**
 - Air recirculation, refer to Recirculated air mode **110, 113**
 - Air supply
 - air conditioner **110**
 - automatic climate control **112**
 - ventilation **111, 114**
 - Air vents **110**
 - Air volume **110, 113**
- AKI, refer to Fuel grade **175**
- Alarm system **32**
 - avoiding unintentional alarms **33**
 - interior motion sensor **33**
 - switching off an alarm **32**
 - tilt alarm sensor **33**
- ALL program **114**
- All-season tires, refer to Winter tires **196**
- All-wheel drive, refer to xDrive **92**
- Ambient air, refer to Recirculated air mode **110, 113**
- AM waveband **144**
- Antifreeze
 - coolant **200**
 - washer fluid **69**
- Antilock Brake System ABS **90**
- Anti-theft alarm system, refer to Alarm system **32**
- Approved axle loads, refer to Weights **237**
- Approved engine oils **200**
- Approved gross vehicle weight, refer to Weights **237**
- Armrest, refer to Center armrest **120**
- Ashtray **122**
- Assist systems, refer to Driving stability control **90**
- AUC Automatic recirculated air control **113**
- Audio device, external **121**
- Automatic
 - air distribution **113**
 - air volume **113**
 - cruise control **69, 71**
 - headlamp control **103**
- Automatic car washes **204**
- Automatic climate control **109**
- Automatic curb monitor **51**
- Automatic high beams and low beams, refer to High-beam Assistant **106**
- Automatic recirculated air control AUC **113**
- Automatic station search **144**
- Automatic station storage **144**

Automatic transmission with Steptronic 60

- interlock 60
- overriding selector lever lock 62
- shiftlock, refer to Changing selector lever position 60
- sport program 61
- towing 217
- tow-starting 217

AUTO program for automatic climate control 113

AUTOSTORE 144

AUX-IN

- port 121

AUX-In connection 151

AUX-IN port 143

Average fuel consumption 80

- setting the units 83

Average speed 80, 81

Avoiding unintentional alarms 33

Axle loads, refer to Weights 237

B

Backrest contour, refer to Lumbar support 44

Backrests, refer to Seat adjustment 43

Backrest width adjustment 44

Back seats

- refer to Rear seats 46

Bag holder 124

Band-aids, refer to First aid pouch 215

Bar, refer to Towing methods 218

Base plate for telephone or mobile phone

- refer to Snap-in adapter 165
- refer to Snap-in adapter in the center armrest storage compartment 120

Battery 212

- charging 212
- disposal 35, 213
- jump-starting 216
- remote control 24
- replacing 212
- temporary power failure 212

Battery renewal

- remote control 35
- remote control for vehicle 35

Being towed 217

Belt hand-over 49

- pinch protection system 50

Belts, refer to Safety belts 49

Belt tensioner, refer to Safety belts 49

Beverage holders, refer to Cupholders 121

Black ice, refer to Outside temperature warning 78

Blinds, refer to Roller sunblinds 120

Blower, refer to Air volume 110, 113

Bluetooth, activating/deactivating 157

BMW

- car shampoo 207

BMW Assist 167

- activating 168

BMW Homepage 4

BMW Maintenance System 202

BMW Professional radio

- recalling stations 144
- sampling stations 144
- satellite radio 146
- selecting waveband 144
- station search 144
- storing stations 144
- switching on/off 142
- tone control 143
- volume 142

BMW Teleservices 168

- activating 168

BMW webpage 4

Bottle holders, refer to Cupholders 121

Brake Assist, refer to Dynamic Brake Control DBC 90

Brake fluid, refer to Service requirements 84

Brake Force Display 98

Brake lamps

- Brake Force Display 98

Brake pads 132

- breaking in 132

Brake pedal, refer to Braking safely 134

Brake rotors 135

- brakes 132
- breaking in 132

Brakes

- ABS 90
- BMW Maintenance System 202
- Brake Force Display 98
- breaking in 132
- parking brake 59
- service requirements 84

Brakes, refer to Braking safely 134

Brake system 132

- BMW Maintenance System 202
- breaking in 132
- disc brakes 135

Breakdown services, refer to Roadside Assistance 215

Breaking in the clutch 132

Breaking in the differential, refer to Engine and differential 132

Break-in period 132

Bulb changing, refer to Lamps and bulbs 208

Button for starting the engine, refer to Start/Stop button 57

Buttons on the steering wheel 11

C

California Proposition 65
warning 6

Call

– accepting 160

– ending 161

– rejecting 161

Calling, refer to Phone
numbers, dialing 161

Calling, refer to Telephone
owner's manual

Can holders, refer to

Cupholders 121

Capacities 239

Capacity of the cargo area 237

Car battery, refer to Vehicle
battery 212

Car care, refer to Care 204

Care 204

– automatic car washes 204

– care products 204

– carpets 207

– CD/DVD drives 207

– chrome parts 206

– displays 207

– exterior 204

– fine wood parts 207

– headlamps 205

– high-pressure washer 205

– interior 206

– leather 206

– light-alloy wheels 206

– paintwork 205

– plastic parts 207

– retractable hardtop 205

– rubber seals 206

– safety belts 207

– sensors and cameras 207

– upholstery and cloth
trim 206

– washing the car
manually 205

– windows 205

Cargo, securing 137

Cargo area

– capacity 237

– Comfort Access 34

– folding up the floor
panel 125

– lamp, refer to Interior
lamps 107

– opening from inside 31

– opening from outside 31

Cargo loading 135

– securing cargo 137

– stowing cargo 136

– vehicle 135

Car jack

– jacking points 212

Car key, refer to Integrated
key/remote control 24

Car phone

– installation location, refer to
Center armrest 120

– refer to separate Owner's
Manual

Car phone, refer to
Telephone 156

Car radio, refer to Radio 18

Car radio, refer to Radio BMW
Professional 142

Car shampoo 207

Catalytic converter, refer to
Hot exhaust system 134

CD changer 147

– controls 18

– fast forward/reverse 148

– installation location 148

– random sequence 148

– selecting a CD 147

– selecting a track 148

– volume 142

CD player 147

– changing the track 148

– controls 18

– fast forward/reverse 148

– playing a track 148

– random order 148

– volume 142

Center armrest 120

Center brake lamp

– replacing bulb 211

Center console, refer to
Around the center
console 14

Central locking

– from inside 29

– from outside 25

Central locking system 25

– Comfort Access 33

– hotel function 31

– setting unlocking
characteristics 26

Changes, technical, refer to
For your own safety 5

Changing bulbs, refer to
Lamps and bulbs 208

Changing gears 64

Changing wheels 211

Chassis number, refer to
Engine compartment 197

Check Control 87

Child restraint fixing system
LATCH 54

Child restraint systems 53

Child seats, refer to
Transporting children
safely 53

Chrome parts 207

Chrome polish 207

Cigarette lighter, refer to
Lighter 122

Cleaning headlamps 68

– washer fluid 69

Cleaning your BMW, refer to
Care 204

Climate control

– automatic air
distribution 113

Clock 78

– 12h/24h format 83

– setting time 86

Closing

– from inside 29

– from outside 25

Clothes hooks 121

Cockpit 10

Cold start, refer to Starting the engine [58](#)
Comfort Access [33](#)
– replacing the battery [35](#)
Comfort access, refer to Comfort Access [33](#)
Comfort area, refer to Around the center console [14](#)
Compartment for remote control, refer to Ignition lock [57](#)
Compass [118](#)
Compressed audio files [147](#)
Computer [80](#)
Concierge service [168](#)
Condensation, refer to When the vehicle is parked [135](#)
Condition Based Service CBS [202](#)
Configuring settings, refer to Personal Profile [24](#)
Confirmation signal for vehicle locking/unlocking [27](#)
ConnectedDrive [167](#)
Connecting vacuum cleaner, refer to Connecting electrical appliances [123](#)
Consumption, refer to Average fuel consumption [80](#)
Controls and displays [10](#)
Convenient loading in Convertible [27](#)
Convenient opening and closing
– glass roof [26](#)
– glass roof with Comfort Access [34](#)
– retractable hardtop [26](#)
– windows [26](#)
– windows with Comfort Access [34](#)
– with Comfort Access [34](#)

Convertible
– bag holder [124](#)
– convenient loading [27](#)
– enlarging cargo area [124](#)
– folding down rear backrest [124](#)
– retractable hardtop [38](#)
– rollover protection system [101](#)
Coolant [200](#)
– checking level [201](#)
Coolant temperature [200](#)
Cooling, maximum [113](#)
Cooling fluid, refer to Coolant [200](#)
Cooling system, refer to Coolant [200](#)
Copyright [2](#)
Corner-illuminating lamps
– replacing bulbs [209](#)
Cornering light, refer to Adaptive Light Control [105](#)
Correct tires [195](#)
Courtesy lamps, refer to Interior lamps [107](#)
Cruise control [69](#)
– active [71](#)
– malfunction [71](#)
Cruise control, refer to Active Cruise Control [71](#)
Cruising range [80, 81](#)
Cupholders [121](#)
Curb weight, refer to Weights [237](#)

D

Dashboard, refer to Cockpit [10](#)
Dashboard, refer to Instrument cluster [12](#)
Dashboard lighting, refer to Instrument lighting [107](#)

Data, technical [234](#)
– capacities [239](#)
– dimensions [235](#)
– engine [234](#)
– weights [237](#)
Data memory [203](#)
Date
– setting [86](#)
Date setting [144](#)
Daytime running lights [104](#)
– replacing bulbs [209](#)
DBC Dynamic Brake Control [90](#)
Deactivating front passenger airbags [100](#)
Deadlocking, refer to Locking [26](#)
Defect
– door lock [29](#)
– fuel filler flap [174](#)
– glass roof [37](#)
Defogging windows [111](#)
Defrost, windows [111](#)
Defrosting windows and removing condensation
– air conditioner [111](#)
Defrosting windshield, refer to Defrosting windows [111](#)
Defrost position, refer to Defrosting windows [111](#)
Digital clock [78](#)
Digital compass [118](#)
Digital radio, refer to HD Radio™ reception [145](#)
Dimensions [235](#)
Directional indicators, refer to Turn signals [67](#)
Displacement, refer to Engine data [234](#)
Display [18](#)
Display lighting, refer to Instrument lighting [107](#)
Displays, refer to Instrument cluster [12](#)
Displays and controls [10](#)

- Disposal
 - coolant [200](#)
 - remote control battery [35](#)
 - vehicle battery [213](#)
 - Distance remaining to service, refer to Service requirements [84](#)
 - Distance warning, refer to Park Distance Control PDC [89](#)
 - Door key, refer to Remote control with integrated key [24](#)
 - Door lock [29](#)
 - Doors, emergency operation [29](#)
 - DOT Quality Grades [193](#)
 - Draft-free ventilation [111](#), [115](#)
 - Drinks holders, refer to Cupholders [121](#)
 - Drive mode [64](#)
 - Drive-off assistance, refer to Dynamic Stability Control DSC [90](#)
 - Drive-off assistant [93](#)
 - Driving dynamics control [65](#)
 - Driving lamps, refer to Parking lamps/low beams [103](#)
 - Driving notes [132](#)
 - Driving off on hills, refer to Drive-off assistant [93](#)
 - Driving stability control systems [90](#)
 - Driving through water [134](#)
 - Driving tips, refer to Driving notes [132](#)
 - Dry air, refer to Cooling function [114](#)
 - DSC Dynamic Stability Control [90](#)
 - DTC Dynamic Traction Control [91](#)
 - indicator/warning lamp [91](#)
 - Dynamic Brake Control DBC [90](#)
 - Dynamic Stability Control DSC [90](#)
 - indicator/warning lamp [91](#)
- ## E
- EBV Electronic brake-force distribution [90](#)
 - Eject button [18](#), [148](#)
 - Electrical defect
 - 7-gear Sport automatic transmission with double clutch [65](#)
 - Electrical malfunction
 - door lock [29](#)
 - driver's door [29](#)
 - fuel filler flap [174](#)
 - glass roof [37](#)
 - Electric seat adjustment [44](#)
 - Electric steering wheel lock
 - with Comfort Access [34](#)
 - Electronic brake-force distribution EBV [90](#)
 - Electronic oil level check [198](#)
 - Electronic Stability Program ESP, refer to Dynamic Stability Control DSC [90](#)
 - Emergency actuation, automatic transmission, refer to Overriding selector lever lock [62](#)
 - Emergency operation
 - fuel filler flap, manual release [174](#)
 - Emergency operation, refer to Closing manually
 - glass roof [37](#)
 - Emergency operation, refer to Manual operation
 - door lock [29](#)
 - Emergency release
 - trunk lid from inside [31](#)
 - Emergency Request [214](#)
 - Emergency services, refer to Roadside Assistance [215](#)
 - Energy, saving
 - saving fuel [132](#)
 - Engine
 - breaking in [132](#)
 - data [234](#)
 - overheated, refer to Coolant temperature [200](#)
 - speed [234](#)
 - starting [58](#)
 - starting, Comfort Access [33](#)
 - switching off [59](#)
 - Engine compartment [197](#)
 - Engine coolant, refer to Coolant [200](#)
 - Engine oil
 - adding [199](#)
 - additives, refer to Approved engine oils [200](#)
 - alternative oil types [200](#)
 - approved engine oils [200](#)
 - BMW Maintenance System [202](#)
 - capacity [239](#)
 - checking level [198](#)
 - intervals between changes, refer to Service requirements [84](#)
 - Engine output, refer to Engine data [234](#)
 - Engine speed, refer to Engine data [234](#)
 - Engine starting, refer to Starting the engine [58](#)
 - Entry lamps, refer to Interior lamps [107](#)
 - Equalizer [143](#)
 - ESP Electronic Stability Program, refer to Dynamic Stability Control DSC [90](#)
 - Exhaust system, refer to Hot exhaust system [134](#)
 - Exterior mirrors [50](#)
 - adjusting [50](#)
 - automatic dimming feature [51](#)
 - automatic heating [51](#)
 - folding in and out [50](#)
 - External audio device [121](#), [143](#)

Eyes

- for tow-starting and towing away [217](#)
- for tying down loads [137](#)

F

Failure messages, refer to
Check Control [87](#)

Failure of an electrical
consumer [213](#)

False alarm

- avoiding unintentional alarm [33](#)
 - switching off an alarm [32](#)
- Fastening safety belts, refer to
Safety belts [49](#)

Fast forward

- CD [148](#)

Fault messages, refer to
Check Control [87](#)

Filter

- refer to Microfilter/activated-charcoal filter for automatic climate control [115](#)
- refer to Microfilter for air conditioner [111](#)

First aid pouch [215](#)

Fixture for remote control,
refer to Ignition lock [57](#)

Flash when locking/
unlocking [27](#)

Flat tire

- Run-flat tires [196](#)
- Tire Pressure Monitor TPM [95](#)

Flat Tire Monitor FTM [93](#)

- indicating a flat tire [94](#)
- indicator/warning lamp [94](#)
- initialization [93](#)
- snow chains [93](#), [196](#)
- system limits [93](#)

Flat tires, refer to Tire
condition [194](#)

Fluid reservoir, refer to
Washer fluid reservoir [69](#)

FM waveband [144](#)

Fog lamps [107](#)

- indicator lamp [107](#), [220](#)
 - Folding up the floor panel [125](#)
- Footwell lamps, refer to
Interior lamps [107](#)

For your own safety [5](#)

Four-wheel drive, refer to
xDrive [92](#)

Front airbags [99](#)

FTM, refer to Flat Tire
Monitor [93](#)

Fuel [175](#)

- average consumption [80](#)
- gauge [79](#)
- high-quality brands [175](#)
- quality [175](#)
- specifications [175](#)
- tank contents, refer to Capacities [239](#)

Fuel clock, refer to Fuel
gauge [79](#)

Fuel consumption indicator
– average fuel
consumption [80](#)

Fuel display, refer to Fuel
gauge [79](#)

Fuel filler flap [174](#)

- releasing in the event of
electrical malfunction [174](#)

Fuses [213](#)

G

Garage door opener, refer to
Integrated universal remote
control [116](#)

Gasoline

- refer to Average
consumption [80](#)

Gasoline, refer to Required
fuel [175](#)

Gasoline display, refer to Fuel
gauge [79](#)

Gear indicator, automatic
transmission with
Steptronic [60](#)

Gear indicator, refer to
Displays in the instrument
cluster [63](#)

Gearshift lever [62](#)

- automatic transmission with
Steptronic [60](#)
- manual transmission [60](#)

Gearshifts

- automatic transmission with
Steptronic [60](#)
- manual transmission [60](#)

General driving notes [133](#)**Glass roof, electric [37](#)**

- closing after electrical
malfunction [37](#)
- convenient opening and
closing [26](#), [29](#)
- convenient opening and
closing with Comfort
Access [34](#)
- initializing [37](#)
- opening, closing [37](#)
- pinch protection system [37](#)
- power failure [37](#)
- remote control [26](#)
- tilting [37](#)

Glove compartment [120](#)**Gong**

- volume [142](#)

Grills, refer to Air vents [110](#)

Gross vehicle weight, refer to
Weights [237](#)

H

Handbrake, refer to Parking
brake [59](#)

Hands-free system [14](#), [163](#)**Hazard warning flashers [14](#)****HDC Hill Descent Control [92](#)****HD Radio™ reception [145](#)****Head airbags [99](#)**

Headlamp control,
automatic [103](#)

Headlamp flasher [67](#)

- indicator lamp [11](#), [14](#), [220](#)

Head Light, refer to Adaptive Light Control [105](#)
Head restraints [45](#)
– rear, removing [46](#)
– sitting safely [42](#)
Heated
– mirrors [51](#)
– rear window [111](#), [114](#)
– seats [48](#)
– steering wheel [52](#)
Heating [109](#)
– mirrors [51](#)
– rear window [111](#), [114](#)
– seats [48](#)
– steering wheel [52](#)
Heating and ventilation, refer to Climate [109](#)
Heavy loads, refer to Stowing cargo [136](#)
Height, refer to Dimensions [235](#)
Height adjustment
– seats [43](#)
– steering wheel [52](#)
High-beam Assistant [106](#)
High beams [105](#)
– headlamp flasher [105](#)
– indicator lamp [220](#)
High beams and low beams, automatic, refer to High-beam Assistant [106](#)
High-pressure washer [204](#), [205](#)
High water, refer to Driving through water [134](#)
Hill Descent Control HDC [92](#)
Hills [135](#)
Holders for cups [121](#)
Homepage BMW [4](#)
Hood [198](#)
Hooks for shopping bags [125](#)
Horn [10](#), [11](#)
Hotel function, refer to Locking or unlocking separately [31](#)

Hot exhaust system [134](#)
Hydraulic brake assist, refer to Dynamic Brake Control [90](#)
Hydroplaning [134](#)

I

Ice warning, refer to Outside temperature warning [78](#)
Identification marks
– Run-flat tires [196](#)
– tire coding [193](#)
Ignition [58](#)
– switched off [58](#)
– switched on [58](#)
Ignition key, refer to Remote control with integrated key [24](#)
Ignition key position 1, refer to Radio readiness [57](#)
Ignition key position 2, refer to Ignition on [58](#)
Ignition lock [57](#)
Imprint [2](#)
Indicator and warning lamps [13](#)
– Tire Pressure Monitor TPM [96](#)
Indicator and warning lamps, overview [220](#)
Individual air distribution [110](#)
Inflation pressure, refer to Tire inflation pressure [177](#)
Inflation pressure monitoring, refer to Tire Pressure Monitor TPM [95](#)
Initializing
– after power failure [212](#)
– compass, refer to Calibrating [119](#)
– Flat Tire Monitor FTM [93](#)
– glass roof [37](#)
Installation location
– CD changer [148](#)
– telephone [120](#)

Instrument cluster [12](#)
Instrument cluster, refer to Cockpit [10](#)
Instrument combination, refer to Instrument cluster [12](#)
Instrument lighting [107](#)
Integrated key [24](#)
Integrated universal remote control [116](#)
Interior lamps [107](#)
– remote control [27](#)
Interior motion sensor [33](#)
Interior rearview mirror [51](#)
– automatic dimming feature [51](#)
– compass [118](#)
Interlock, refer to Disengaging the remote control [60](#)
Intermittent mode of the wipers [68](#)

J

Jacking points [212](#)
Jumpering, refer to Jump-starting [216](#)
Jump-starting [216](#)

K

Key, refer to Integrated key/remote control [24](#)
Keyless go, refer to Comfort Access [33](#)
Keyless opening and closing, refer to Comfort Access [33](#)
Key Memory, refer to Personal Profile [24](#)
Keypad dialing [162](#)
Kickdown [61](#)
– automatic transmission with Steptronic [61](#)
Knock control [175](#)

L

Lamps
– automatic headlamp control [103](#)
– parking lamps/low beams [103](#)
Lamps and bulbs, replacing bulbs [208](#)
Lap-and-shoulder belt, refer to Safety belts [49](#)
Lashing eyes, refer to Securing cargo [137](#)
LATCH child restraint fixing system [54](#)
Launch Control [66](#)
Leather care [206](#)
LED Light-emitting diodes [209](#)
Length, refer to Dimensions [235](#)
License plate lamp, replacing bulb [211](#)
Light
– high-beam assistant [106](#)
Light-alloy wheels [206](#)
Light-emitting diodes LED [209](#)
Lighter [122](#)
– connecting electrical appliances [123](#)
Lighting
– instruments [107](#)
– lamps and bulbs [208](#)
– vehicle, refer to Lamps [103](#)
Light switch [103](#)
Listening to scan samples
– BMW Professional radio [144](#)
Load [136](#)
Load securing equipment, refer to Securing cargo [137](#)
Lock buttons, doors, refer to Locking [30](#)

Locking
– adjusting confirmation signal [27](#)
– from inside [30](#)
– from outside [26](#)
– without remote control, refer to Comfort Access [33](#)
Locking and unlocking doors
– confirmation signals [27](#)
– from inside [29](#)
– from outside [25](#)
Low beam control, refer to High-beam Assistant [106](#)
Low-beam headlamps [103](#)
– automatic [103](#)
– indicator lamp, defective bulb [231](#)
Lower back support, refer to Lumbar support [44](#)
Luggage rack, refer to Roof-mounted luggage rack [137](#)
Lumbar support [44](#)

M

M+S tires, refer to Winter tires [196](#)
Maintenance, refer to Service and Warranty Information Booklet for US models or in the Warranty and Service Guide Booklet for Canadian models
Maintenance system [202](#)
Malfunction
– automatic transmission with Steptronic [62](#)
– tires [94](#)
Malfunction warnings, refer to Check Control [87](#)
Manual air distribution [110](#)
Manual car wash [205](#)
Manually unlocking parking lock [65](#)
Manual mode, automatic transmission with Steptronic [61](#)
Manual operation
– door lock [29](#)
– driver's door [29](#)
– fuel filler flap [174](#)
– glass roof [37](#)
– parking lock [65](#)
– parking lock, automatic transmission [62](#)
Manual station search [144](#)
Manual transmission [60](#)
Master key, refer to Remote control with integrated key [24](#)
Maximum cooling [113](#)
Maximum speed
– with winter tires [196](#)
Measurements, refer to Dimensions [235](#)
Memory, refer to Seat and mirror memory [48](#)
Microfilter
– BMW Maintenance System [202](#)
– for air conditioner [111](#)
– for automatic climate control [115](#)
Microfilter/activated-charcoal filter
– BMW Maintenance System [202](#)
Microphone
– telephone [14](#)
Mirror dimming feature [51](#)
Mirrors [50](#)
– automatic curb monitor [51](#)
– exterior mirrors [50](#)
– heating [51](#)
– interior rearview mirror [51](#)
– memory, refer to Seat and mirror memory [48](#)
Mirrors, folding in before entering a car wash [50](#)

Mobile phone

- adjusting volume [160](#)
- connecting, refer to Mobile phone, pairing [157](#)
- installation location, refer to Center armrest [120](#)
- pairing [157](#)
- refer to separate Owner's Manual

Mobile phone, installation location, refer to Center armrest [120](#)

Mobile phone, refer to the separate Owner's Manual

Modifications, technical, refer to For your own safety [5](#)

Monitoring system for tire pressures, refer to Flat Tire Monitor [93](#)

MP3 [147](#)

Multifunctional steering wheel, refer to Buttons on the steering wheel [11](#)

Multifunction switch

- refer to Turn signals/headlamp flasher [67](#)
- refer to Wiper system [68](#)

Music tracks

- playing a track [148](#)
 - random order [148](#)
- My Info [170](#)

N

Neck support, refer to Head restraints [45](#)

Nets, refer to Storage compartments [121](#)

Neutral [63](#)

New tires [195](#)

Next Service indicator, refer to Condition Based Service CBS [202](#)

Number of cylinders, refer to Engine data [234](#)

Nylon rope, refer to Tow rope [218](#)

O

OBD socket, refer to Socket for Onboard Diagnosis [203](#)

Octane ratings, refer to Fuel specifications [175](#)

Odometer [78](#)

Oil, refer to Engine oil [198](#)

Oil consumption [198](#)

Oil level [198](#)

Old batteries, refer to Disposal [213](#)

Onboard vehicle tool kit [208](#)

Opening and closing

- Comfort Access [33](#)
- from inside [29](#)
- from outside [25](#)
- using the door lock [29](#)
- using the remote control [25](#)

Opening and closing retractable hardtop [39](#)

Outlets

– refer to Ventilation [111](#), [114](#)

Outlets, refer to Air vents [110](#)

Output, refer to Engine data [234](#)

Outside-air mode

- automatic climate control [113](#)

Outside temperature display [78](#)

- changing unit of measure [83](#)
- in computer [83](#)

Outside temperature warning [78](#)

Overheated engine, refer to Coolant temperature [200](#)

Overriding selector lever lock [62](#)

P

Paintwork care [205](#)

Park assistant, refer to Park Distance Control [89](#)

Park Distance Control PDC [89](#)

Parking

– vehicle [59](#)

Parking aid, refer to Park Distance Control PDC [89](#)

Parking brake [59](#)

– indicator lamp [59](#)

Parking lamps [103](#)

– replacing bulbs [209](#)

Parking lamps/low beams [103](#)

Parts and accessories, refer to Vehicle equipment [5](#)

Passenger side mirror tilt function [51](#)

Pathway lighting [104](#)

PDC

– volume [142](#)

Personal Profile [24](#)

Phone numbers

– dialing [161](#)

Pinch protection system

- glass roof, electric [37](#)
- windows [36](#)

Playing a track, scan

– CD [148](#)

Polish [207](#)

Pollen

– refer to Microfilter/activated-charcoal filter for automatic climate control [115](#)

– refer to Microfilter for air conditioner [111](#)

Power failure [212](#)

Power windows [35](#)

Power windows, refer to Windows [35](#)

Pressure, tires [177](#)

Pressure monitoring, tires [93](#)

– Flat Tire Monitor [93](#)

Pressure monitoring of tires, refer to Tire Pressure Monitor TPM [95](#)

Programmable buttons on the steering wheel [11](#)

Protection function, refer to Pinch protection system

- glass roof, electric [37](#)
- windows [36](#)

Providing medical assistance,
refer to First aid pouch **215**
PTY **145**
Puncture
– Flat Tire Monitor **93**

R

Radio **18**
– autostore **144**
– controls **18**
– refer to separate Owner's
Manual
– switching on/off **18**
– volume **18**
Radio, refer to BMW
Professional radio **144**
Radio position, refer to Radio
readiness **57**
Radio readiness **57**
– switched off **58**
– switched on **57**
Radio-remote key, refer to
Remote control with
integrated key **24**
Rain sensor **68**
RDS **145**
Reading lamps **108**
Rear lamps, refer to Tail
lamps **210**
Rear seats
– adjusting head restraints **46**
– folding down backrests **123**
Rear ventilation **115**
Rearview mirror, refer to
Mirrors **50**
Rear window
defroster **111, 114**
Rear window roller blind, refer
to Roller sunblinds **120**
Reception
– radio station **144**
Recirculated air
mode **110, 113**
Recirculation of air, refer to
Recirculated air
mode **110, 113**

Reclining seat, refer to
Backrest **43**
Refueling **174**
Releasing
– hood **198**
Remaining distance, refer to
Cruising range **80**
Remote control **24**
– battery renewal **35**
– Comfort Access **33**
– garage door opener **116**
– malfunction **28, 35**
– removing from the ignition
lock **57**
– service data **202**
– trunk lid **27**
Replacement fuses, refer to
Fuses **213**
Replacement remote
control **24**
Replacing bulbs, refer to
Lamps and bulbs **208**
Replacing tires **195**
Replacing tires, refer to New
wheels and tires **195**
Reporting safety defects **7**
Reserve warning, refer to Fuel
gauge **79**
Reset, resetting tone
settings **144**
Restraint systems
– for children **53**
– refer to Safety belts **49**
Retractable hardtop **38**
– care, refer to Caring for your
vehicle brochure
– convenient opening and
closing **26**
– remote control **26**
Reverse
– CD **148**
Reverse gear **63**
– automatic transmission with
Steptronic **61**
– manual transmission **60**
Roadside
Assistance **169, 215**

Roadside parking lamps **105**
– replacing bulbs **209**
Roadworthiness test, refer to
Service requirements **84**
Roller sunblinds **120**
Rollover protection system,
Convertible **101**
– resetting **101**
Roof load capacity **237**
Roof-mounted luggage
rack **137**
Rope, refer to Tow-starting,
towing away **218**
RSC Runflat System
Component, refer to Run-
flat tires **196**
Runflat System Component
RSC, refer to Run-flat
tires **196**
Run-flat tires **196**
– continuing driving with a
damaged tire **94**
– flat tire **94**
– Flat Tire Monitor **94**
– inflation pressure **177**
– new tires **195**
– tire replacement **195**
– winter tires **196**
Runflat tyres, refer to Run-flat
tires **196**

S

Safety-belt height
adjustment **49**
Safety belts **49**
– belt hand-over **49**
– damage **49**
– indicator/warning lamp **49**
– reminder **49**
– sitting safely **42**

- Safety systems
 - airbags [99](#)
 - Antilock Brake System ABS [90](#)
 - brake system [90](#)
 - driving stability control [90](#)
 - Dynamic Stability Control DSC [90](#)
 - rollover protection system, Convertible [101](#)
 - safety belts [49](#)
- Safety tires, refer to Run-flat tires [196](#)
- Satellite radio [146](#)
 - activating [146](#)
- Saving fuel [132](#)
- Scan
 - CD changer [148](#)
- Scan, listening to samples
 - BMW Professional radio [144](#)
- Scan, sampling tracks
 - CD changer [148](#)
 - CD player [148](#)
- Screw thread for tow fitting [217](#)
- Search button [19](#)
- Searching
 - CD player [148](#)
- Searching for a music track
 - CD [148](#)
- Seat adjustment
 - electric [44](#)
 - mechanical [43](#)
- Seat and mirror memory [48](#)
- Seat belt reminder, refer to Fasten safety belts reminder [49](#)
- Seat heating [48](#)
- Seats [43](#)
 - adjusting electrically [44](#)
 - adjusting the seats [43](#)
 - heating [48](#)
 - memory, refer to Seat and mirror memory [48](#)
 - saving a setting, refer to Seat and mirror memory [48](#)
 - sitting safely [42](#)
- Securing cargo [126](#), [128](#)
- Securing the vehicle
 - from inside [29](#)
 - from outside [25](#)
- Selecting distance for Active Cruise Control [73](#)
- Selecting the sound pattern [143](#)
- Selector lever
 - automatic transmission with Steptronic [60](#)
- Selector lever lock, refer to Changing selector lever positions, shiftlock [60](#)
- Selector lever positions [62](#)
 - automatic transmission with Steptronic [60](#)
- Service, refer to Roadside Assistance [215](#)
- Service car, refer to Roadside Assistance [215](#)
- Service data in the remote control [202](#)
- Service Interval Display, refer to Condition Based Service CBS [202](#)
- Service requirements [84](#)
- Service status [170](#)
- Settings
 - clock, 12h/24h format [83](#)
- Settings and information [82](#)
- Setting the time format [144](#)
- Shifting [64](#)
 - 7-gear Sport automatic transmission with double clutch [64](#)
- Shifting gears
 - automatic transmission with Steptronic [61](#)
 - manual transmission [60](#)
- Shift into a drive position, refer to selector lever positions [62](#)
- Shiftlock
 - automatic transmission, refer to Changing selector lever positions [60](#)
- Shift paddles on the steering wheel [64](#)
- Side airbags [99](#)
- Side windows, refer to Windows [35](#)
- Signal horn, refer to Horn [10](#), [11](#)
- Sitting safely [42](#)
 - with airbags [42](#)
 - with head restraint [42](#)
 - with safety belts [42](#)
- Ski bag [126](#)
- Ski bag for Convertible, refer to Through-loading opening with integrated transport bag [127](#)
- Sliding/tilt sunroof, refer to Glass roof, electric [37](#)
- Slot for remote control [57](#)
- Smokers' package, refer to Ashtray [122](#)
- Snap-in adapter
 - inserting/removing [165](#)
 - use [156](#)
- Snap-in adapter, refer to Center armrest storage compartment [120](#)
- Socket, Onboard Diagnosis OBD [203](#)
- Socket, refer to Connecting electrical appliances [123](#)
- SOS, refer to Sending an Emergency Request [214](#)
- Spare fuses [213](#)
- Special oils, refer to Approved engine oils [200](#)
- Specified engine oils, refer to Approved engine oils [200](#)
- Speed
 - Run-flat tires [94](#)
 - with winter tires [196](#)
- Speed-dependent volume [143](#)
- Speedo, refer to Speedometer [12](#)
- Speedometer [12](#)

- Sport automatic transmission
 - with double clutch [62](#)
 - driving dynamics control [65](#)
 - kickdown [64](#)
 - Launch Control [66](#)
 - manually unlocking parking lock [65](#)
 - neutral [63](#)
 - reverse gear [63](#)
- Sport program with 7-gear Sport automatic transmission with double clutch [64](#)
- Spray nozzles, refer to
 - Cleaning windshield and headlamps [68](#)
- Stability control, refer to
 - Driving stability control systems [90](#)
- Start/Stop button [57](#)
 - starting the engine [58](#)
 - switching off the engine [59](#)
- Starting, refer to Starting the engine [58](#)
- Starting assistance, refer to
 - Jump-starting [216](#)
- Starting CD changer [147](#)
- Starting difficulties
 - jump-starting [216](#)
- Starting the CD player [147](#)
- Starting the engine
 - Start/Stop button [57](#)
- Stations, refer to BMW Professional radio [144](#)
- Station search
 - BMW Professional radio [144](#)
- Status of this Owner's Manual at time of printing [5](#)
- Steam jet [204, 205](#)
- Steering wheel [52](#)
 - adjustment [52](#)
 - buttons on steering wheel [11](#)
 - heating [52](#)
 - lock [57](#)
 - locking with Comfort Access [34](#)
 - shift paddles [64](#)
- Steering wheel buttons, refer to Shift paddles [64](#)
- Steering with variable ratio, refer to Active steering [97](#)
- Steptronic, refer to Automatic transmission with Steptronic [60](#)
- Storage [207](#)
- Storage compartments [121](#)
- Storage nets [125](#)
- Storing seat positions, refer to
 - Seat and mirror memory [48](#)
- Storing tires [196](#)
- Stowage, refer to Storage compartments [121](#)
- Summer tires, refer to Wheels and tires [177](#)
- Switches, refer to Cockpit [10](#)
- Switching off
 - engine [59](#)
- Switching off the engine
 - Start/Stop button [57](#)
- Switching on
 - BMW Professional radio [142](#)
 - CD changer [147](#)
 - CD player [147](#)
 - radio [18](#)
- Switching the cooling function on and off [114](#)
- Symbols [4](#)
- T**
- Tachometer [79](#)
- Tailgate, refer to Trunk lid [31](#)
- Tail lamp, refer to Tail lamps [210](#)
- Tail lamps [210](#)
 - replacing bulb [210, 211](#)
- Tank contents, refer to
 - Capacities [239](#)
- Technical data [234](#)
 - dimensions [235](#)
- Technical modifications, refer to For your own safety [5](#)
- Telephone [156](#)
 - hands-free system [163](#)
 - installation location, refer to
 - Center armrest [120](#)
 - refer to separate Owner's Manual
 - voice commands [163](#)
- Temperature
 - air conditioner [111](#)
 - automatic climate control [112](#)
 - coolant, refer to Coolant temperature [200](#)
- Temperature display
 - outside temperature [78](#)
 - outside temperature warning [78](#)
 - setting the units [83](#)
- Tempomat, refer to Cruise control [69](#)
- Tensioning straps, refer to
 - Securing cargo [137](#)
- Third brake lamp, refer to
 - Center brake lamp [211](#)
- Through-loading opening with integrated transport bag [127](#)
- Through-loading system [123](#)
- Tilt alarm sensor [33](#)
- Tilt function, passenger side mirror [51](#)
- Time
 - displaying [144](#)
 - setting [144](#)
- Tire inflation pressure [177](#)
 - loss [94](#)
- Tire pressure monitoring, refer to Flat Tire Monitor [93](#)

- Tire Pressure Monitor
 - TPM 95
 - resetting the system 95
 - system limitations 95
 - warning lamp 96
 - Tire puncture, refer to Flat Tire Monitor 94
 - Tire Quality Grading 193
 - Tires
 - age 193, 195
 - air loss 96
 - breaking in 132
 - changing, refer to Changing wheels 211
 - condition 194
 - damage 194
 - inflation pressure 177
 - labels 193
 - minimum tread depth 194
 - new wheels and tires 195
 - pressure monitoring, refer to Flat Tire Monitor 93
 - pressure monitoring, refer to Tire Pressure Monitor TPM 95
 - puncture 94
 - replacing 195
 - Run-flat tires 196
 - size 193
 - storage 196
 - tread depth 194
 - wear indicators, refer to Minimum tread depth 194
 - wheel/tire combination, refer to Correct wheels and tires 195
 - winter tires 196
 - Tone
 - control 143
 - middle setting 144
 - Tools, refer to Onboard vehicle tool kit 208
 - Top, refer to Retractable hardtop 38
 - Torque, refer to Engine data 234
 - Tow bar 218
 - Tow fitting 217
 - screw thread 217
 - Tow fittings for tow-starting and towing away 217
 - Towing 217
 - car with automatic transmission 217
 - methods 218
 - with 7-gear Sport automatic transmission with double clutch 218
 - Towing and tow-starting 217
 - Tow rope 218
 - Tow-starting 217, 219
 - TPM, refer to Tire Pressure Monitor 95
 - Traction control, refer to Dynamic Stability Control DSC 90
 - Transmission
 - 7-gear Sport automatic transmission with double clutch 62
 - automatic transmission with Steptronic 60
 - idle position 63
 - Launch Control 66
 - manually unlocking parking lock 65
 - manual transmission 60
 - overriding selector lever lock for automatic transmission with Steptronic 62
 - reverse gear 63
 - Transmission interlock
 - refer to Changing selector lever position 60
 - refer to P Park 60
 - Transporting children safely 53
 - Transport securing devices, refer to Securing cargo 137
 - Tread depth, refer to Minimum tire tread 194
 - Trip-distance counter, refer to Trip odometer 78
 - Triple turn signal activation 67
 - Trip odometer 78
 - Trunk lid 31
 - Comfort Access 34
 - emergency release 31
 - locking or unlocking separately 31
 - opening from inside 31
 - opening from outside 31
 - remote control 27
 - Turning circle, refer to Dimensions 235
 - Turn signal 67
 - Turn signal indicators
 - indicator/warning lamp 12
 - Turn signals
 - triple turn signal 67
 - Tying down loads, refer to Cargo loading 137
- ## U
- Uniform Tire Quality Grading/UTQR 193
 - Units
 - average fuel consumption 83
 - Units of measure
 - temperature 83
 - Universal garage door opener, refer to Integrated universal remote control 116
 - Unlatching, refer to Unlocking 33
 - Unlocking
 - from inside 30
 - from outside 25
 - setting unlocking characteristics 26
 - trunk lid 34
 - without remote control, refer to Comfort Access 33
 - USB audio interface 151

V

- Variable light distribution,
 - refer to Adaptive Light Control 105
- Vehicle
 - battery 212
 - breaking in 132
 - cargo loading 135
 - identification number, refer to Engine compartment 197
 - measurements, refer to Dimensions 235
 - parking 59
 - weight 237
- Vehicle equipment 5
- Vehicle jack 212
- Vehicle storage 207
- Ventilation 114
 - air conditioner 111
 - draft-free 111, 115
 - in the rear 115
- Ventilation, refer to Climate 109
- Vents, refer to Air vents 110
- Vents, refer to Ventilation 111, 114
- Voice commands
 - telephone 163
- Voice phone book 164
- Volume
 - fuel tank, refer to Capacities 239
 - gong 142
 - mobile phone 160
 - PDC 142
 - setting speed-dependent 143

W

- Warning and indicator lamps 13
- Warning and indicator lamps, overview 220
- Warning messages, refer to Check Control 87
- Warning triangle 215
- Washer fluid 69
 - content of the reservoir 69
- Washer fluid reservoir 69
- Waste tray, refer to Ashtray 122
- Water on roads, refer to Driving through water 134
- Water penetration 204, 205
- Waveband 144
- Wear indicators in tires, refer to Minimum tread depth 194
- Weights 237
- Welcome lamps 104
- Wheel/tire combination, refer to Correct wheels and tires 195
- Wheelbase, refer to Dimensions 235
- Wheels, new 195
- Wheels and tires 177
- Width, refer to Dimensions 235
- Wind deflector 40
- Windows 35
 - convenient opening and closing 26
 - convenient opening and closing with Comfort Access 34
 - opening, closing 35
 - pinch protection system 36
- Windows, defrosting 111
- Windshield
 - cleaning 68
 - defrosting and removing condensation 111
- Windshield wash 68
 - filling capacity, reservoir 239
 - nozzles 69
 - reservoir for washer fluid 69
 - washer fluid 69
- Windshield wiper blades, changing 208
- Windshield wipers, refer to Wiper system 68

- Winter tires 196
 - storage 196
- Wiper blade replacement 208
- Wiper system 68
- WMA 147
- Work in the engine compartment 198
- Wrench/screwdriver, refer to Onboard vehicle tool kit 208

X

- xDrive 92
- Xenon lamps
 - replacing bulb 209

Y

- Your individual vehicle
 - settings, refer to Personal Profile 24

More about BMW



The Ultimate
Driving Machine

bmwusa.com

01 40 2 609 312 ue Basis

