

Supplementary  
Owner's Manual  
for BMW  
Z4 M Roadster/  
Z4 M Coupe



The Ultimate  
Driving Machine





## Z4 M Roadster Z4 M Coupe

### Supplementary Owner's Manual for Vehicle

Congratulations, and thank you for choosing a BMW Z4 M Roadster/Z4 M Coupe.

Thorough familiarity with your BMW Z4 M Roadster/Z4 M Coupe will provide you with enhanced control and security when you drive it. Therefore, we have one request:

Before starting off in your new BMW Z4 M Roadster/Z4 M Coupe, please take the time to read this Supplementary Owner's Manual and familiarize yourself with the information that we have compiled for you. The manual contains important data and instructions intended to assist you in obtaining maximum satisfaction from your BMW Z4 M Roadster's/Z4 M Coupe's unique array of advanced technical features.

We wish you an enjoyable driving experience.

BMW AG

© 2007 Bayerische Motoren Werke  
Aktiengesellschaft  
Munich, Germany  
Reprinting, including excerpts, only with the  
written consent of BMW AG, Munich.  
Order No. 01 41 0 013 330  
US English III/07  
Printed in Germany  
Printed on environmentally friendly paper,  
bleached without chlorine, suitable for recycling.

# Contents

The fastest way to find information on special topics is by using the index starting on page [42](#).

## Using this Owner's Manual

[4](#) Notes

## At a glance

[8](#) Cockpit

## Controls

[16](#) Driving

[17](#) Everything under control

[18](#) Technology for driving comfort and safety

## Driving tips

[22](#) Special operating instructions

## Mobility

[26](#) Refueling

[27](#) Wheels and tires

[28](#) Under the hood

[31](#) Replacing components

## Reference

[38](#) Technical data

[42](#) Everything from A to Z

# Notes

## About this Owner's Manual

This Supplementary Owner's Manual contains all the important equipment, instructions and technical data in which differs BMW Z4 M Roadster/Z4 M Coupe differ from the BMW Z4. For descriptions of equipment not included in this Supplementary Owner's Manual, please refer to the Owner's Manual for the BMW Z4 or additional brochures in the vehicle's literature.

We have made every effort to ensure that you will find what you need in this Supplementary Owner's Manual as quickly as possible. The fastest way to find specific topics is to refer to the detailed index at the back of the manual. If you wish to gain an initial overview of your vehicle, you will find this in the first chapter.

Should you sell your BMW Z4 M Roadster/Z4 M Coupe some day, please remember to hand over the Supplementary Owner's Manual as well; it is an important component of your vehicle.

## Symbols used



Indicates precautions that must be followed precisely in order to avoid the possibility of personal injury and serious damage to the vehicle.



Indicates information that will assist you in gaining the optimum benefit from your vehicle and enable you to care more effectively for your vehicle.



Refers to measures that can be taken to help protect the environment.

◀ Marks the end of a specific item of information.

\* Indicates special equipment, country-specific equipment and optional extras, as well as equipment and functions not yet available at the time of printing.

## Symbol on vehicle parts



Indicates that you should consult the relevant section of this Owner's Manual for information on a particular part or assembly.

## Your individual vehicle

When you ordered your BMW, you chose various items of equipment. This Owner's Manual describes all models and equipment that BMW offers within the same group.

We hope you will understand that equipment and features are included which you might not have chosen for your vehicle. Any differences can easily be identified since all optional accessories and special equipment are marked with an asterisk \*.

If equipment in your BMW Z4 M Roadster/Z4 M Coupe is not described in this Supplementary Owner's Manual, please refer to the Owner's Manual for the BMW Z4.

## Status at time of printing

BMW pursues a policy of continuous, ongoing development that is conceived to ensure that our vehicles continue to embody the highest quality and safety standards combined with advanced, state-of-the-art technology. For this reason, it is possible that features described in this Supplementary Owner's Manual could differ from those on your vehicle.



A blurred, blue-tinted image of a car, likely a sedan, is the background of the page. The car is positioned horizontally, with its front on the left and rear on the right. The image is out of focus, showing only the general shape and color of the vehicle. The background is a solid dark blue color.

## **At a glance**

This overview of buttons, switches and displays is intended to familiarize you with your vehicle's operating environment. The section will also assist you in becoming acquainted with the control concepts and options available for operating the various systems.

# Cockpit

## Around the steering wheel: controls and displays

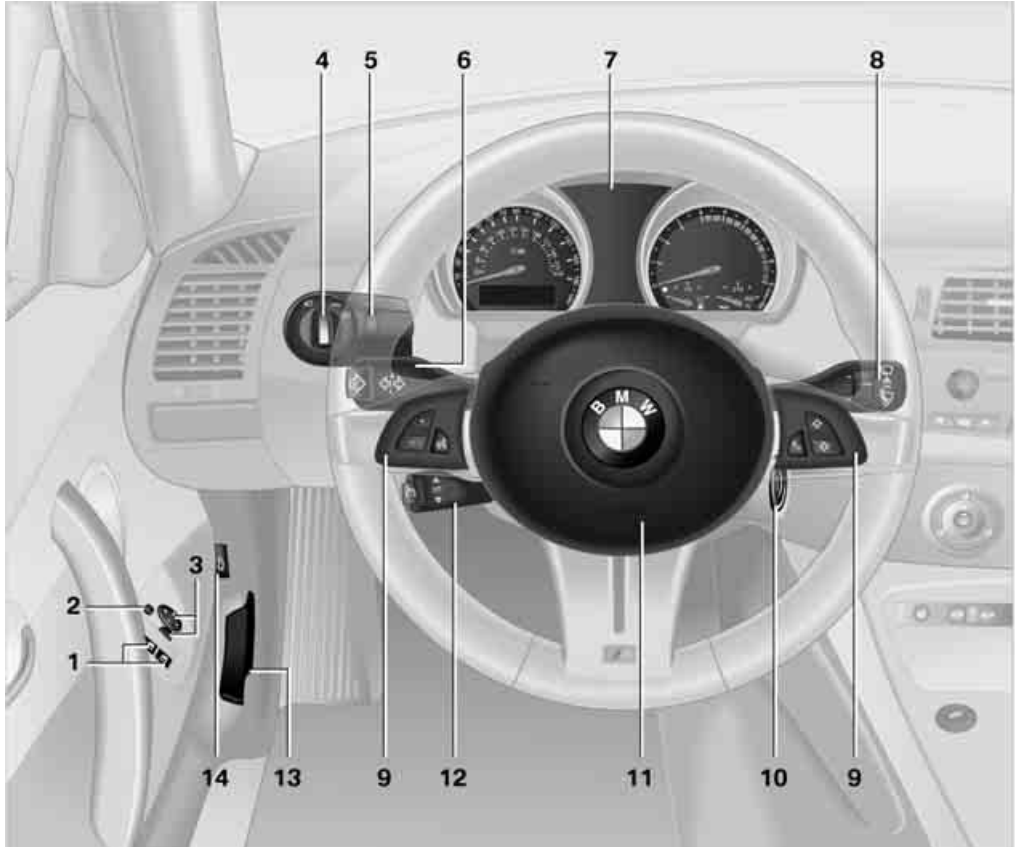

 For descriptions of equipment listed here without a page reference, please refer to the Owner's Manual for the BMW Z4 under the respective term. ◀

1  Opening and closing windows

2 Folding exterior mirrors in or out\*



3 Adjusting exterior mirrors

4  Parking lamps

 Low beams

 Automatic headlamp control\*



5  Instrument lighting

- 6  Turn signal indicators
-  High beams, headlamp flasher
-  Roadside parking lamps\*
- BC Computer

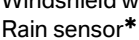
7 Instrument cluster 10

- 8  Windshield wipers
-  Rain sensor\*

9 Buttons on the steering wheel

-  +
- Volume
-  -

- 
  - ▷ Press: to accept and end a telephone call; to start dialing for selected telephone numbers
  - ▷ Press longer: activate and deactivate voice entry\*

-  Fast forward/rewind
  - ▷ Radio
  - ▷ Press: next station stored
  - ▷ Press longer: station search
  - ▷ CD
  - ▷ Press: jump to next track
  - ▷ Press longer: fast forward/rewind
  - ▷ Telephone
  - ▷ Scan register of names

- R/T Display/hide telephone book. Display the entries one after another with the forward/backward buttons

10 Ignition lock

11 Horn: the entire surface

- 12  Cruise control\*

13 Releasing the hood

- 14 Opening the luggage compartment lid/tailgate

## Instrument cluster

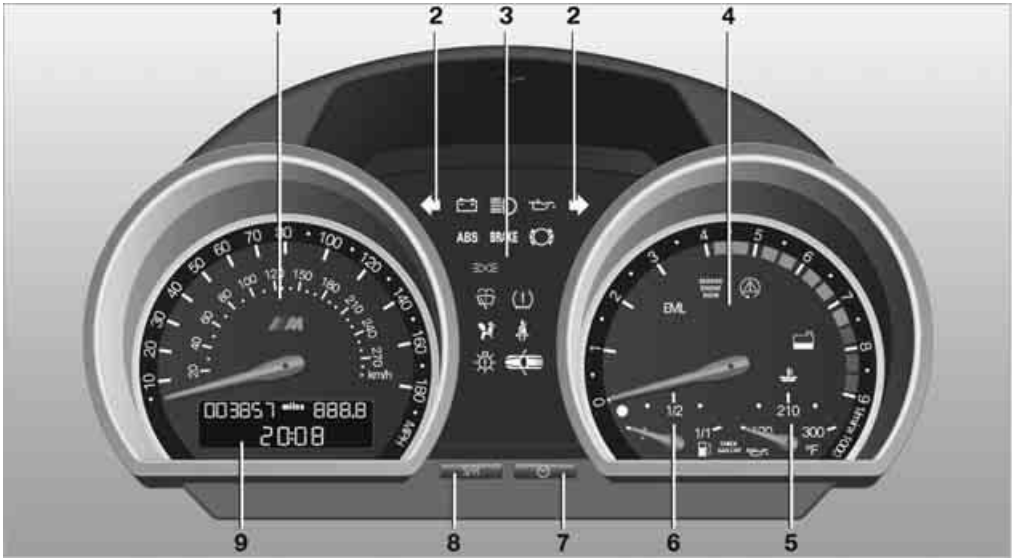

▶ For descriptions of equipment listed here without a page reference, please refer to the Owner's Manual for the BMW Z4 under the respective term. ◀

- 1 Speedometer
- 2 Indicator lamps for turn signals
- 3 Indicator and warning lamps 10
- 4 Tachometer 17  
with indicator and warning lamps 10
- 5 Engine oil thermometer 17
- 6 Fuel gauge 17
- 7 Button for
  - ▶ Displaying the clock
  - ▶ Service interval display
- 8 Button for
  - ▶ Resetting trip odometer
  - ▶ Setting the clock
- 9 Display for
  - ▶ Trip odometer/Odometer
  - ▶ Clock
  - ▶ Service interval
  - ▶ Computer

## Indicator and warning lamps

## Technology that monitors itself

Indicator and warning lamps that are identified by ● are tested for proper functioning whenever the ignition key is turned. They each light up once for different periods of time.

If a malfunction occurs in one of the monitored systems, the corresponding lamp does not go out after the engine has started, or it lights up again while the vehicle is in motion. More information can be found on the specified pages or in the Owner's Manual for the BMW Z4 under the respective terms.

◀▶ Turn signal indicators

🔋 Battery charge current ●

☰ Headlamp flasher/High beams

🛢 Engine oil pressure/  
Engine oil level ● 28

**ABS** Antilock Brake System ABS/Driving stability control systems ●

 Antilock Brake System ABS/Driving stability control systems for Canadian models

**BRAKE** Brake system ●

 Brake warning lamp for Canadian models

 Brake pads ●

 Parking lamps/Low beams

 Flat Tire Monitor\* ● 18  
Tire Pressure Monitor\* ● 18

 Airbags ●

 Safety belt reminder

 Defective bulb

 Doors or luggage compartment lid/tail-gate open

**EML** Engine electronics ●  
Malfunction in the engine electronics. You can continue to drive with reduced engine output. Please have the system inspected by your BMW center.

 SERVICE ENGINE SOON  
Service engine soon ●

 Service engine soon indicator lamp for Canadian models

 Dynamic Stability Control DSC ● 18

 Add coolant

 Add washer fluid

 Coolant temperature 17

 CHECK GAS CAP  
Check gas cap ●

## Colors

The indicator and warning lamps can light up in various colors and combinations.

- ▷ Red:  
Stop the vehicle immediately or an important reminder
- ▷ Red and yellow:  
Continue driving cautiously
- ▷ Yellow:  
Have the system checked soon or for your information
- ▷ Green or blue:  
For your information

## Around the center console: controls and displays



 For descriptions of equipment listed here without a page reference, please refer to the Owner's Manual for the BMW Z4 under the respective term. ◀

- 1 Reading lamps\*
- 2 Interior lamps
- 3 Automatic climate control



Air distribution

AUTO

Automatic air distribution and flow rate



Cooling function



Automatic recirculated-air control  
AUC



Recirculated-air mode



Maximum cooling



Air flow rate



Defrosting windows



Rear window defroster

- 4  Seat heating\*



Roadster: opening the convertible top



Roadster: closing the convertible top



DSC Dynamic Stability Control 18



Flat Tire Monitor FTM\*  
Tire Pressure Monitor TPM\*

- 5 Indicator/warning lamp for passenger air-bags
- 6 Central locking system
- 7 Hazard warning flashers
- 8 Dynamic Driving Control 16



A blurred, blue-tinted photograph of a car's interior, showing the dashboard, steering wheel, and center console. The image is out of focus, emphasizing the overall layout and color scheme.

## Controls

This chapter is intended to provide you with information for complete control of your vehicle. All features and accessories that are useful for driving and for your safety, comfort and convenience, are described here.

# Driving

## Dynamic Driving Control

In contrast to the descriptions in the Owner's Manual for the BMW Z4, please take note of the following differences for your BMW Z4 M Roadster/Z4 M Coupe.

At the touch of a button, the Dynamic Driving Control's Sport mode enables you to drive your BMW in an even sportier style:

The engine responds more spontaneously to any motion of the accelerator pedal.

### Activating the system

- ▷ Car at standstill:  
With the key in position 2, press the SPORT button.  
The LED in the button comes on.
- ▷ While driving:  
Press the SPORT button.  
The LED in the button comes on.  
The system is activated when you release the accelerator pedal.

### Deactivating the system

Press the SPORT button again.  
The LED in the button goes out.

# Everything under control

## Tachometer



The orange warning zone between arrows **1** and **2** shows the currently permissible engine speed, which depends on engine temperature. As engine temperature increases, some of the LEDs in this warning zone go out one after another.

As much as possible, avoid driving at engine speeds within the illuminated warning zone.

Never force the engine speed up into the red warning zone beginning at arrow **2**. To protect the engine, the fuel supply is interrupted when speed reaches this sector.

## Fuel gauge

### Reserve

In contrast to the descriptions in the Owner's Manual for the BMW Z4, the reserve level for the BMW Z4 M Roadster/Z4 M Coupe is approx. 2.6 US gallons/10 liters.

## Coolant temperature

In contrast to the descriptions in the Owner's Manual for the BMW Z4, your BMW Z4 M Roadster/Z4 M Coupe is not equipped with a coolant temperature gauge.

Should the coolant and thus the engine become too hot, a warning lamp will come on in the instrument cluster.

## Red warning lamp



The engine is overheated. Reduce your speed immediately and pull over at a suitable location. Switch off the engine and allow it to cool down. Contact your nearest BMW center or a workshop that works according to BMW repair procedures with correspondingly trained personnel.



Do not open the hood, otherwise there is a risk of injury from scalding. ◀

## Yellow warning lamp



The engine is too warm. Continue driving, but in a moderate manner, so that the engine can cool down.

If the warning lamp comes on again, have the engine checked without delay.

## Engine oil thermometer



The general operating temperature lies between 175 °F/80°C and 250 °F/120°C. Do not exceed the maximum temperature of 300 °F/150°C.

## Service interval display



Regardless of your service requirements, have the breaking-in inspection performed by your BMW center after driving 1,200 miles/2,000 km. ◀

# Technology for driving comfort and safety

## Driving stability control systems

In contrast to the descriptions in the Owner's Manual for the BMW Z4, your BMW Z4 M Roadster/Z4 M Coupe does not feature Dynamic Traction Control DTC.

### Dynamic Stability Control DSC

DSC prevents slip at the drive wheels while starting off and accelerating the vehicle. DSC also recognizes unstable vehicle conditions, such as fishtailing or nose-diving. In these cases, and subject to physical limits, DSC helps to keep the vehicle on a steady course by reducing engine speed and by applying brakes at individual wheels.

 The laws of physics cannot be repealed even with DSC. It will always be the driver's responsibility to drive in a manner that matches road conditions. Therefore, do not limit the additional safety margin by practicing risky driving. ◀

### Deactivating DSC



Press the button; the DSC indicator lamp in the instrument cluster lights up. No more interventions to increase stability and forward momentum are carried out.

To enhance vehicle stability, reactivate DSC as soon as possible.

### Activating DSC

Press the button briefly; the indicator lamp goes out in the instrument cluster.

### Checking

 The indicator lamp flashes: DSC controls the drive forces and brake forces.

The indicator lamp is lit: DSC is deactivated.

## Flat Tire Monitor FTM\*

In contrast to the descriptions in the Owner's Manual for the BMW Z4, your BMW Z4 M Roadster/Z4 M Coupe is not equipped with Run-Flat Tires. You should therefore observe the following when you receive a flat tire warning.

### Flat tire warning

 The warning lamp in the instrument cluster lights up in red. A signal also sounds. There is a flat tire or substantial loss of tire pressure.

1. Reduce speed and pull the vehicle over carefully. Avoid strong braking and steering maneuvers.
2. Determine which tire is damaged. To do this, check the tire inflation pressure using the M Mobility System, refer to Restoring tire inflation pressure on page 33.
3. Use the M Mobility System to repair the flat tire, refer to page 31.

## Tire Pressure Monitor TPM\*

In contrast to the descriptions in the Owner's Manual for the BMW Z4, your BMW Z4 M Roadster/Z4 M Coupe is not equipped with Run-Flat Tires. Therefore, note the following if the system warns of low tire inflation pressure.

## Warning of low tire inflation pressure



The warning lamp lights up in yellow. A signal also sounds. There is a flat tire or a significant loss of tire pressure in one or more tires.

1. Reduce speed and pull the vehicle over carefully. Avoid strong braking and steering maneuvers.
2. Identify the damaged wheel or wheels. To do this, check the tire inflation pressure using the M Mobility System, refer to Restoring tire inflation pressure on page 33.



If the damaged wheel cannot be identified, contact your BMW center. ◀

3. Use the M Mobility System to repair the flat tire, refer to page 31.

Have the damaged tire replaced at the BMW center or at a workshop that works according to BMW repair procedures with correspondingly trained personnel.

## Power steering

In contrast to the descriptions in the Owner's Manual for the BMW Z4, your BMW Z4 M Roadster/Z4 M Coupe is equipped with hydraulic power steering.



## **Driving tips**

This section provides you with information useful in dealing with specific driving and operating conditions.

# Special operating instructions

## Break-in procedures

In contrast to the descriptions in the Owner's Manual for the BMW Z4, please take note of the following differences for your BMW Z4 M Roadster/Z4 M Coupe.

Always obey all official speed limits.

## Engine and differential

### Up to 1,200 miles/2,000 km

Drive at varying engine and road speeds, but do not exceed 5,500 rpm or 105 mph/170 km/h.

Strictly avoid depressing the accelerator pedal to full-throttle position.

After the breaking-in inspection at 1,200 miles/2,000 km, engine or road speeds can be gradually increased.

## Transmission

The function of the transmission reaches its optimal level only after driving a distance of approx. 300 miles/500 km. Do not exceed engine speeds of 5,500 rpm during this time.

## After replacing components

The same break-in procedures should be observed if any of the components mentioned above have to be renewed in the course of the vehicle's operating life.

## Driving notes

### Ground clearance



The front spoiler greatly restricts the vehicle's ground clearance. Make sure that your BMW always has sufficient ground clearance, e.g. when entering underground garage complexes or driving over the edge of a curb; otherwise the front spoiler could be damaged. ◀

### Braking safely

In contrast to the descriptions in the Owner's Manual for the BMW Z4, your BMW Z4 M Roadster/Z4 M Coupe is equipped with perforated brake discs.

In certain braking situations, operation of the perforated brake discs can cause noise; however, this does not affect the performance and operating safety of the brakes.







## Mobility

This section helps you maintain your car's mobility by supplying important information on vital topics including fuels and lubricants, wheels and tires, service, maintenance and breakdown assistance.

# Refueling

## Note when refueling

In contrast to the descriptions in the Owner's Manual for the BMW Z4, please take note of the following differences for your BMW Z4 M Roadster/Z4 M Coupe.

### Fuel tank capacity

Approx. 14.5 US gallons/55 liters, including the reserve capacity of approx. 2.6 US gallons/10 liters.

 Do not drive until the tank is empty. Otherwise, the engine may not operate properly and damage could result. ◀

## Fuel specifications

 Do not fill the tank with leaded fuel, as this would cause permanent damage to the catalytic converter.

Do not fill the tank with E85, i.e. fuel that contains 85% ethanol, nor with Flex Fuel, as this would cause damage to the engine and fuel supply system. ◀

## Required fuel

### Super Premium Gasoline/AKI 93

Always use this premium grade fuel to obtain maximum fuel economy and performance. The minimum approved fuel grade is AKI 91.

 Do not fill the tank with gasoline below the specified minimum grade; otherwise engine damage could result. ◀

# Wheels and tires

## Correct wheels and tires

In contrast to the descriptions in the Owner's Manual for the BMW Z4, your BMW Z4 M Roadster/Z4 M Coupe is not equipped with Run-Flat Tires.

## Information for your safety

The factory-approved radial-ply tires are specifically matched to your vehicle and offer optimal road safety as well as enhanced driving comfort if used properly.

In the event of a flat tire, proceed as described under M Mobility System, refer to page 31.

## Z4 M Roadster: tire inflation pressures

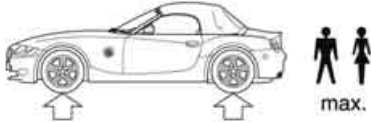
Tire size	Pressure specifications in psi/kPa	
All pressure specifications in the table are indicated in psi/kilopascal with cold tires, cold = ambient temperature		
Front: 225/45 ZR 18	30/210	–
Rear: 255/40 ZR 18	–	32/220
225/40 R 18 92 V M+S	33/230	36/250

You will find more information about permissible loads and weights on page 41.

## Z4 M Coupe: tire inflation pressures

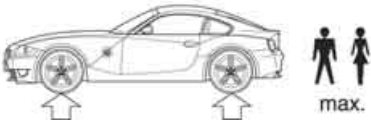
Tire size	Pressure specifications in psi/kPa	
All pressure specifications in the table are indicated in psi/kilopascal with cold tires, cold = ambient temperature		
Front: 225/45 ZR 18	30/210	–
Rear: 255/40 ZR 18	–	32/220
225/40 R 18 92 V M+S	33/230	38/260

You will find more information about permissible loads and weights on page 41.

## Snow chains\*

Snow chains may be attached only to winter tires of the size 225/40R 18 on both rear wheels.

 Do not initialize the Flat Tire Monitor if snow chains are mounted\*, as this may cause the instrument to issue an incorrect reading.

When driving with snow chains, you may find it helpful to deactivate DSC temporarily, refer to page 18. ◀

# Under the hood

## Important parts in the engine compartment

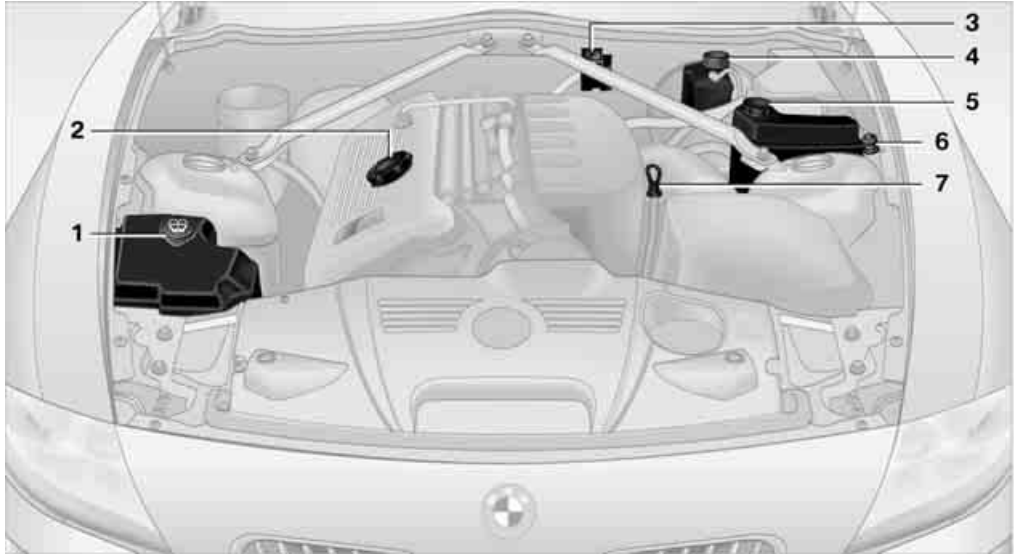

- |  |   |
|--|---|
| <p><b>1</b> Washer fluid reservoir for headlamp and windshield washer system</p> <p><b>2</b> Filler neck for engine oil, refer to Adding engine oil</p> <p><b>3</b> Jump-starting connection</p> | <p><b>4</b> Reservoir for brake fluid</p> <p><b>5</b> Coolant expansion tank</p> <p><b>6</b> Chassis ground, negative terminal</p> <p><b>7</b> Dipstick for engine oil, refer to Checking the oil level</p> |
|--|---|

## Engine oil

Like fuel consumption, engine oil consumption depends on your driving style and the vehicle's operating conditions.

### Warning lamp

#### Engine oil pressure

- The warning lamp lights up in red:
- The engine oil pressure is too low.
- Stop the vehicle immediately and switch off the engine. Check the engine oil level and top up if necessary. If the oil level is correct, please contact your nearest BMW center or a workshop that works according to BMW repair

procedures with correspondingly trained personnel.

 Do not continue driving, otherwise the engine could sustain serious damage from inadequate lubrication. ◀

#### Engine oil level

- The warning lamp lights up in yellow while you are driving. A signal also sounds.

The oil level is at the absolute minimum; check engine oil level using dipstick **7** and refill as soon as possible. Do not drive more than 30 miles/50 km before refilling.



The warning lamp lights up in yellow after the engine is switched off. A signal also sounds.

Check the engine oil level using dipstick **7** at the earliest opportunity, e.g. when you stop to refuel, and refill engine oil.



The warning lamp lights up in yellow within 30 seconds after the engine is started:

The oil level sensor is defective. Have the system checked as soon as possible.

## Checking the oil level

1. Position the vehicle on a level surface.
2. Switch off the engine when it is at operating temperature.
3. After approx. 1 minute, pull dipstick **7** out and wipe it off with a clean, lint-free cloth, paper towel or something similar.
4. Carefully push the dipstick fully into its tube, then pull it out again.  
The oil level must be between the two marks on the dipstick.

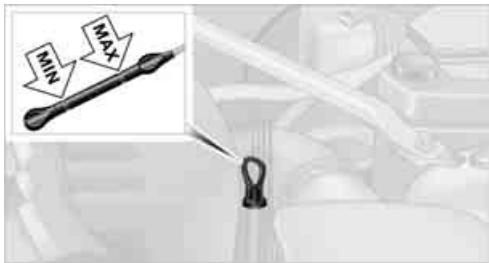

The oil volume between the two marks on the dipstick corresponds to approx. 1.4 US quarts/ 1.3 liters.

## Adding engine oil



Do not add oil until the oil level has dropped almost to the lower mark on the dipstick, refer to Checking the oil level.



Do not add oil beyond the upper mark on the dipstick, otherwise excessive oil can lead to engine damage. ◀

Before you check the engine oil level after adding oil, restart the engine and let it run to obtain a correct reading. Then proceed as described under Checking the oil level.



BMW engines are designed to operate without oil additives; the use of additives could even lead to damage in some cases. The same applies to the transmission and differential as well as to the power steering. ◀



Continuous exposure to used oil has caused cancer in laboratory tests. For this reason, thoroughly wash any areas of skin that have come into contact with oil using soap and water.

Keep oils, greases, etc. out of the reach of children and comply with the warnings on the containers. Otherwise, health hazards may result. ◀



Comply with the applicable environmental regulations concerning the disposal of used oil. ◀

Recommendation: have the oil changed at your BMW center.

## Approved engine oils

The quality of the engine oil is extremely important for the function and life of an engine. BMW only approves specific oils after confirming their suitability for use in its vehicles with extensive testing.

Only use oils specifically approved for your vehicle model.



Your BMW center will be glad to advise you about oils currently approved for your vehicle. ◀

You can also call BMW of North America toll-free at 1-800-831-1117 or visit this website: [www.bmwusa.com](http://www.bmwusa.com) to obtain this information.



Do not use any oil additives, as they could cause engine damage under some circumstances. ◀

## Alternative oil grades

If a high-performance synthetic oil approved by BMW should be unavailable, you may use small volumes of other oils for topping up between oil changes. The following data must appear on the packaging:

- ▷ Viscosity  
preferred: SAE 10W-60  
alternative: SAE 5W-40 or SAE 10W-40
- ▷ Specification  
preferred: API SJ/CF  
alternative: API SJ, also SK, SL, S...

## Low ambient temperatures

The oils used by BMW at the factory for your vehicle model can be used at virtually all ambient temperatures. However, if the vehicle is operated for a longer period at temperatures below  $-4^{\circ}\text{F}$  /  $-20^{\circ}\text{C}$ , your BMW center will be glad to recommend a suitable oil.

# Replacing components

## Onboard tool kit

The onboard tool kit is stored in a tool pouch.

### Roadster



The onboard tool kit can be found on the right-hand side of the cargo bay in a compartment next to the battery cover.

### Coupe: access to onboard tool kit

1. Turn the quick-release fastener counter-clockwise.

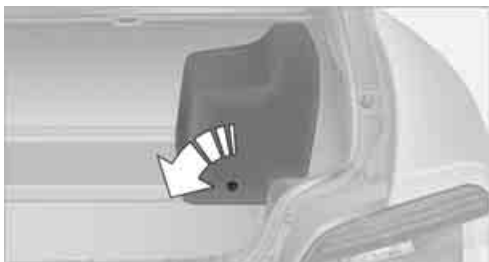

2. Pull out the cover.

 When reinstalling the cover, make sure that its tabs are inserted into the corresponding cut-outs in the cargo bay trim panel. ◀



The onboard tool kit can be found on the right-hand side of the cargo bay on top of the battery.

## M Mobility System

### Repairing a flat tire

To repair a flat tire, an M Mobility System is provided in your BMW Z4 M Roadster/Z4 M Coupe. Using this system you can apply a sealant to the inside of the tire, seal off the damaged area, restore the tire inflation pressure and then continue driving.

-  **Safety measures in the event of a flat:**
- Park the vehicle as far as possible from passing traffic and on solid ground. Switch on the hazard warning flashers.
  - Lock the steering wheel so that the wheels are facing straight ahead. Apply the parking brake and engage first or reverse gear. Have all vehicle occupants get out of the vehicle and ensure that they remain outside the immediate area in a safe place, such as behind a guardrail.
  - If a warning triangle\* or portable hazard warning lamp\* is required, set it up on the roadside at an appropriate distance from the rear of the vehicle. Comply with all national safety guidelines and regulations. ◀

### Preparation

If possible, do not remove foreign bodies which have penetrated the tire.

▶ Corresponding information on using the M Mobility System is also provided on the device. ◀

⚠ Before using the M Mobility System, note the information on the sealant bottle. ◀

Pull the sticker for the speed limit off the sealant bottle and affix it to the steering wheel.

▶ Please observe the expiry date on the sealant bottle. ◀

## Roadster



The M Mobility System is located on the right-hand side of the cargo bay on the battery cover.

▶ With the convertible top closed, fold the convertible top compartment panel up to remove the Mobility Set. ◀

⚠ To avoid any damage when opening the convertible top, make sure that the convertible top compartment panel in the cargo bay has been folded down. ◀

## Coupe: access to the Mobility Set

1. Turn the quick-release fastener counter-clockwise.

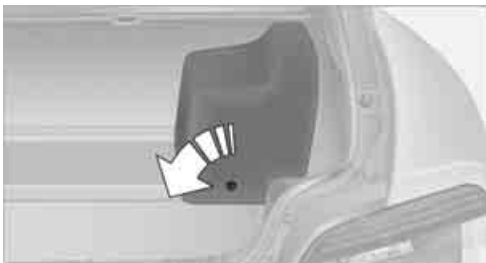

2. Pull out the cover.

▶ When reinstalling the cover, make sure that its tabs are inserted into the corresponding cut-outs in the cargo bay trim panel. ◀



The M Mobility System is located on the right-hand side of the cargo bay in a compartment on top of the battery.

## The M Mobility System consists of



- 1 Sealant bottle and sticker with speed limit
- 2 Filler hose from sealant bottle to wheel

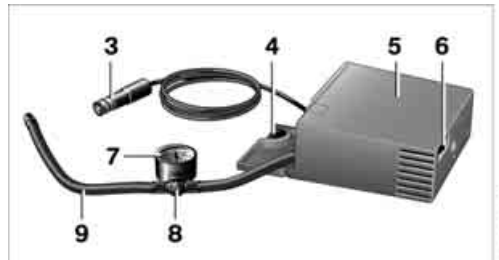

- 3 Cable and connector to cigarette lighter socket
- 4 Mounting for sealant bottle
- 5 Compressor
- 6 On/off switch
- 7 Gauge for indicating tire inflation pressure
- 8 Button for reducing tire inflation pressure
- 9 Hose and connector to wheel

- 9 Connecting hose for connecting compressor and sealant bottle or compressor and wheel

Connector, cable and connecting hose are attached to the bottom of the compressor.

## Using the M Mobility System

To repair a flat tire with the M Mobility System, proceed as follows:

- ▷ Fill sealant into wheel
- ▷ Distribute sealant
- ▷ Restore tire inflation pressure

## Filling sealant into wheel

**⚠** Strictly adhere to the specified order, otherwise highly pressurized sealant could escape. ◀

1. Shake sealant bottle.
2. Screw hose **9** onto connection of sealant bottle.
3. Unscrew and remove dust cap from valve of defective wheel and screw filler hose **2** of sealant bottle onto valve.
4. Insert sealant bottle on compressor housing so that the bottle is in an upright position.

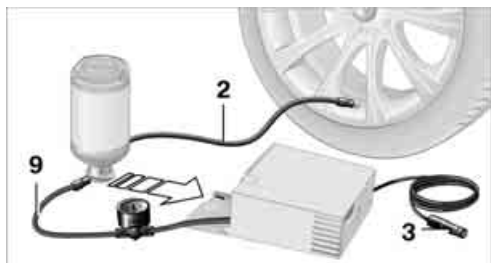

5. Make sure that the device is switched off, position **0**.
6. Insert connector **3** into cigarette lighter socket inside the vehicle.
7. With the ignition switched on: Switch on the device and allow it to run for approx. 3 minutes to fill the wheel with sealant. It is not important what inflation pressure the tire has after this.

8. Switch off device.
9. Remove connecting hoses from connection of sealant bottle and tire valve. Stow the M Mobility System in the vehicle again.

## Distributing sealant

Immediately drive approx. 2 miles/3 km so that the sealant is evenly distributed in the tire.

- ▷ Do not exceed a speed of 35 mph or 60 km/h. Do not drive slower than 12 mph or 20 km/h if possible. ◀

## Restoring tire inflation pressure

1. After approx. 2 miles/3 km, pull over at a suitable location.
2. Screw compressor hose **9** directly onto tire valve.
3. Insert connector **3** into cigarette lighter socket inside the vehicle.
4. Correct tire inflation pressure to 29 psi/200 kPa. With the ignition switched on:
  - ▷ To increase inflation pressure: switch on the compressor, position **I**. To check the current pressure setting, briefly switch off the device.

**⚠** Do not allow the compressor to run for more than 10 minutes, otherwise the device will overheat and may be damaged. ◀

- ▷ To reduce inflation pressure: press button **8**.

- ▷ If the inflation pressure is not maintained, drive the vehicle again, refer to Distributing sealant. Then repeat steps 1 to 4 once.

Using the M Mobility System can be ineffective with tire punctures larger than approx. 1/6 in/4 mm. Please contact the nearest BMW center or a workshop that works according to BMW repair procedures with correspondingly trained personnel if the tire cannot be made ready for driving with the M Mobility System. ◀

**⚠** The tire inflation pressure must be at least 29 psi/200 kPa. Otherwise do not continue driving. ◀

## Continued driving



Do not exceed the permissible maximum speed of 50 mph or 80 km/h, otherwise accidents could result. ◀



Reinitialize the Flat Tire Monitor\* or reset the Tire Pressure Monitor\*. For more information, refer to the BMW Z4 Owner's Manual.

Have the defective tire and the sealant bottle of the M Mobility System replaced as soon as possible. ◀





## Reference

This chapter will help you find the desired information as quickly as possible. It contains the Technical data section as well as the manual's index.

# Technical data

## Engine data

		Z4 M Roadster/Z4 M Coupe
Displacement	cu in/cm <sup>3</sup>	198.1/3,246
Number of cylinders		6
Maximum power output	hp	330
at engine speed	rpm	7,900
Maximum torque	ft lbs/Nm	262/355
at engine speed	rpm	4,900

## Roadster: dimensions

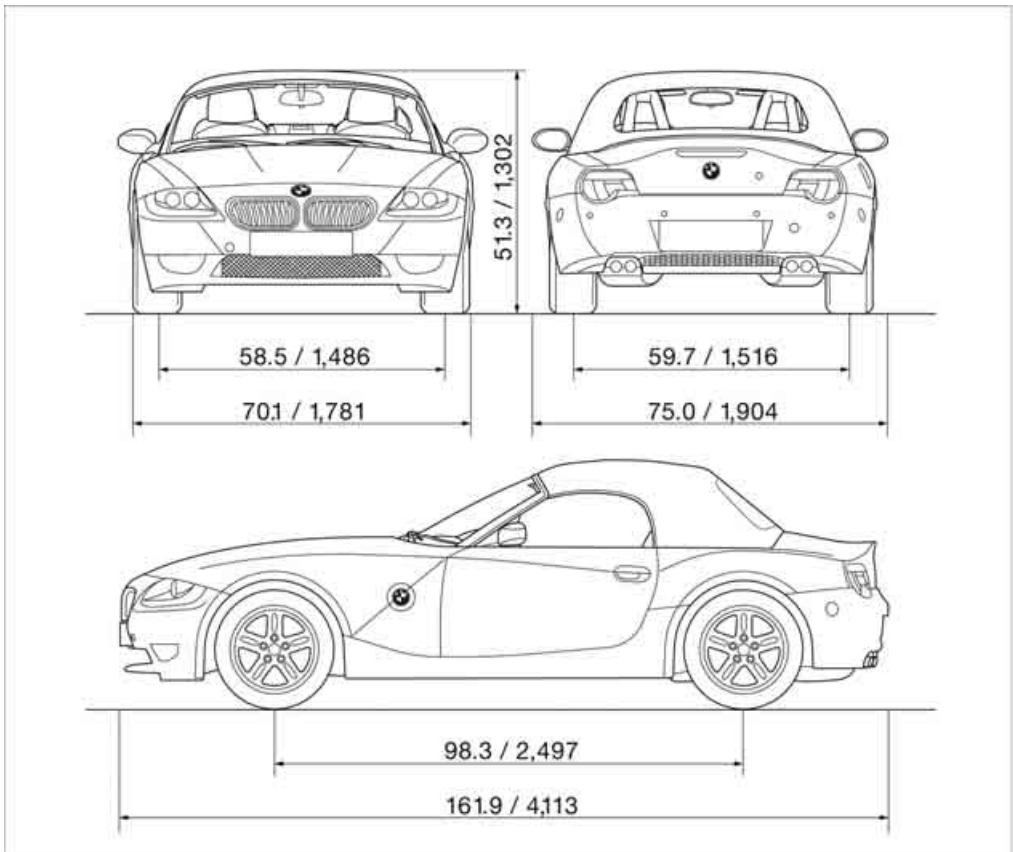

All measurements in inches/millimeters. Smallest turning circle dia. 34 ft 5 in/10.5 m.

Coupe: dimensions

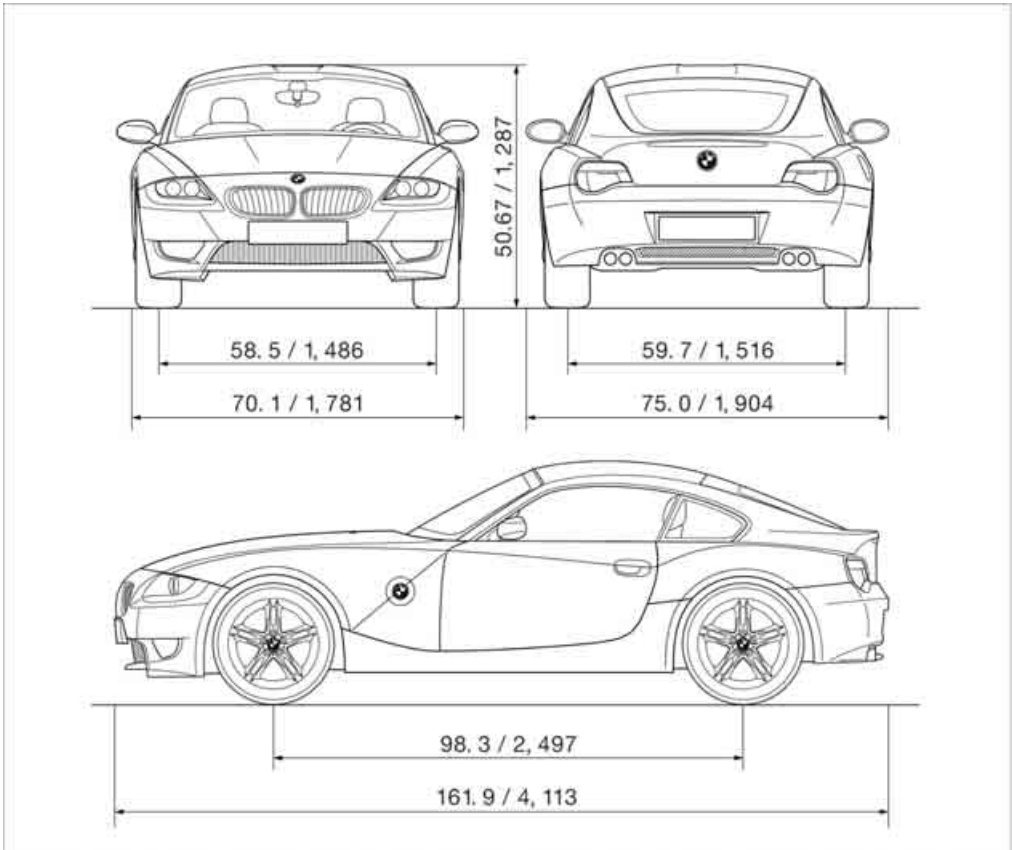

All measurements in inches/millimeters. Smallest turning circle dia. 34 ft 5 in/10.5 m.

## Weights

		Z4 M Roadster
Curb weight	lbs/kg	3,197/1,450
Approved gross vehicle weight	lbs/kg	3,759/1,750
Load	lbs/kg	562/255
Approved front axle load	lbs/kg	1,852/840
Approved rear axle load	lbs/kg	2,006/910
Cargo bay capacity	cu ft/liters	7.1/200
With convertible top compartment panel folded up	cu ft/liters	7.8/220

Never exceed either the approved axle loads or the approved gross vehicle weight.

		Z4 M Coupe
Curb weight	lbs/kg	3,230/1,465
Approved gross vehicle weight	lbs/kg	3,814/1,730
Load	lbs/kg	584/265
Approved front axle load	lbs/kg	1,885/855
Approved rear axle load	lbs/kg	2,061/935
Cargo bay capacity	cu ft/liters	8.7-10.6/245-300

Never exceed either the approved axle loads or the approved gross vehicle weight.

## Capacities

		Notes	
Fuel tank	US gal/liters	approx. 14.5/55	
including reserve of	US gal/liters	approx. 2.6/10	
Window washer system			
including headlamp washers	US quarts/liters	approx. 5.3/5.0	
Manual transmission	US quarts/liters	1.6/1.5	Oil change at breaking-in inspection and during every Inspection II
Differential	US quarts/liters	1.2/1.1	Oil change at breaking-in inspection and during every Inspection II

# Everything from A to Z

## Index

### A

- ABS Antilock Brake System
  - indicator lamp 11
- Accessories, refer to
  - Your individual vehicle 5
- Airbags
  - indicator lamp 11
  - warning lamp 11
- AKI, refer to Fuel specifications 26
- Antilock Brake System ABS
  - indicator lamp 11
- Approved engine oils 29
- Assistance systems, refer to
  - Dynamic Stability Control DSC 18
- Axle loads, refer to Weights 41

### B

- Battery
  - indicator lamp 10
- Brake fluid
  - indicator/warning lamp 11
- Brake hydraulic system
  - indicator/warning lamp 11
- Brake lamps
  - indicator lamp, defective bulb 11
- Brake pad wear indicator
  - warning lamp 11
- Brakes
  - indicator/warning lamps 11
  - operating noise 22
- Brake system
  - indicator/warning lamps 11
- Breaking-in inspection 17
- Breaking in the differential, refer to Engine and differential 22
- Breaking in the transmission, refer to Transmission 22

- Break-in procedures 22
- Buttons on the steering wheel 9

### C

- Capacity
  - cargo bay, refer to Weights 41
- Cargo bay
  - battery cover 31
  - capacity 41
- Center console, refer to
  - Around the center console 12
- Charge indicator lamp 10
- Check gas cap, indicator lamp 11
- Cockpit 8
- Comfort area, refer to Around the center console 12
- Compound brake discs, refer to Braking safely 22
- Consumption display, refer to Fuel gauge 17
- Controls and displays 8
- Coolant
  - indicator lamp 11
- Coolant temperature 17
- Coolant temperature gauge, refer to Coolant temperature 17
- Curb weight, refer to Weights 41
- Customized equipment, refer to Your individual vehicle 5
- Cylinders, refer to Engine data 38

### D

- Dashboard, refer to Cockpit 8

- Data 38
  - dimensions 39, 40
  - engine data 38
  - technical 38
- Data, technical
  - capacities 41
  - engine data 38
  - weights 41
- DBC Dynamic Brake Control
  - warning lamp 11
- Dimensions 39, 40
- Dipstick, engine oil 29
- Displacement, refer to Engine data 38
- Display elements, refer to Instrument cluster 10
- Displays, refer to Instrument cluster 10
- Displays and controls 8
- Drive-off assistance, refer to Dynamic Stability Control DSC 18
- Driving notes 22
- Driving stability control systems 18
- DSC Dynamic Stability Control 18
  - indicator lamp 11, 18
- Dynamic Brake Control DBC
  - indicator lamp 11
- Dynamic Driving Control 16
- Dynamic Stability Control DSC 18
  - indicator lamp 11, 18

### E

- Engine
  - breaking in 22
  - data 38
  - electronics 11
  - indicator lamp 11
  - speed 17

Engine compartment [28](#)  
Engine data [38](#)  
Engine oil [28](#)  
– adding [29](#)  
– additives [29](#)  
– alternative oil grades [30](#)  
– approved engine oils [29](#)  
– dipstick [29](#)  
– indicator/warning lamp [10](#)  
– oil grades, refer also to  
Approved engine oils [29](#)  
Engine oil level [28](#)  
– checking [29](#)  
– indicator/warning lamp [10](#)  
Engine oil pressure [28](#)  
– indicator/warning lamp [10](#)  
Engine oil sensor  
– indicator/warning lamp [10](#)  
Engine oil temperature, refer  
to Engine oil  
thermometer [17](#)  
Engine oil thermometer [17](#)  
Engine output, refer to Engine  
data [38](#)  
Engine speed, refer to Engine  
data [38](#)  
ESP Electronic Stability  
Program, refer to Dynamic  
Stability Control DSC [18](#)

## F

Fasten safety belts  
– warning lamp [11](#)  
Filling sealant into wheel [33](#)  
Flat tire  
– Flat Tire Monitor [18](#)  
– M Mobility System [31](#)  
– Tire Pressure Monitor [18](#)  
Flat tire, refer to Repairing a  
flat tire [31](#)  
Flat Tire Monitor FTM [18](#)  
– indicator/warning  
lamp [11](#), [18](#)  
– snow chains [27](#)  
FTM, refer to Flat Tire  
Monitor [18](#)

Fuel  
– capacity, refer to  
Capacities [41](#)  
– display [17](#)  
– quality [26](#)  
Fuel, refer to Fuel  
specifications [26](#)  
Fuel display, refer to Fuel  
gauge [17](#)  
Fuel reserve indicator, refer to  
Fuel gauge [17](#)  
Fuel tank capacity, refer to  
Capacities [41](#)

## G

Gasoline, refer to Fuel  
specifications [26](#)  
Gross weight, refer to  
Weights [41](#)  
Ground clearance [22](#)

## H

Hazard warning flashers [12](#)  
Headlamp flasher  
– indicator lamp [10](#)  
Headlamp washer reservoir  
– volume, refer to  
Capacities [41](#)  
Height, refer to  
Dimensions [39](#), [40](#)  
High beams  
– indicator lamp [10](#)  
Hood [28](#)  
Horn [8](#)

## I

Indicator/warning lamp  
– brakes [11](#)  
– Flat Tire Monitor [18](#)  
– Tire Pressure Monitor [19](#)  
Indicator and warning lamps,  
overview [10](#)  
Inflation pressure monitoring,  
refer to  
– Flat Tire Monitor [18](#)  
– Tire Pressure Monitor [18](#)

Inspection, refer to Service  
interval display [17](#)  
Instrument cluster [10](#)  
Instrument panel, refer to  
Cockpit [8](#)  
Instrument panel, refer to  
Instrument cluster [10](#)  
Interval  
– display, service [17](#)

## K

Knock control [26](#)

## L

Length, refer to  
Dimensions [39](#), [40](#)  
Longlife oils [30](#)  
– alternative oils [30](#)  
– approved engine oils [29](#)  
Low-beam headlamps  
– indicator lamp [11](#)  
Low beams  
– indicator lamp, defective  
bulb [11](#)  
Luggage compartment  
capacity, refer to Cargo bay  
capacity [41](#)  
Luggage compartment lid  
– indicator lamp [11](#)

## M

M Mobility System [31](#)  
– compressor [32](#)  
– viscosity [32](#)  
Maintenance  
– refer to Service interval  
display [17](#)  
Manufacturer [5](#)  
Measurements, refer to  
Dimensions [39](#), [40](#)  
Mobility System [31](#)

## O

Octane numbers, refer to Fuel  
specifications [26](#)

Oil, refer to Engine oil [28](#)  
 Oil consumption [28](#)  
 Oil grades [29](#)  
 Oil level [28](#)  
 – checking [29](#)  
 – indicator lamp [10](#)  
 Oil pressure [28](#)  
 – indicator/warning lamp [10](#)  
 Oil sensor  
 – indicator lamp [10](#)  
 Oil service [17](#)  
 Onboard tool kit [31](#)

## P

Parking brake  
 – indicator lamp [11](#)  
 Parking lamps  
 – indicator lamp [11](#)  
 Parts and accessories, refer to  
 Your individual vehicle [5](#)  
 Permissible axle load, refer to  
 Weights [41](#)  
 Permissible gross weight,  
 refer to Weights [41](#)  
 Power output, refer to Engine  
 data [38](#)  
 Power steering, hydraulic [19](#)  
 Pressure, tires  
 – restoring with M Mobility  
 System [31](#)  
 Pressure monitoring, tires,  
 refer to  
 – Flat Tire Monitor [18](#)  
 – Tire Pressure Monitor  
 TPM [18](#)

## R

Rear lamps  
 – indicator lamp, defective  
 bulb [11](#)  
 Refueling [26](#)

## S

Safety belts  
 – warning lamp [11](#)

Safety systems, refer to  
 – Dynamic Stability Control  
 DSC [18](#)  
 Sealant bottle, refer to  
 M Mobility System [31](#)  
 Service interval display [17](#)  
 Signal horn, refer to Horn [8](#)  
 Special oils, refer to Approved  
 engine oils [29](#)  
 Specified engine oils [29](#)  
 Speedometer [10](#)  
 Sport program  
 – Dynamic Driving Control [16](#)  
 Stability control, refer to  
 – Driving stability control  
 systems [18](#)  
 – Dynamic Stability Control  
 DSC [18](#)  
 Status at time of printing [5](#)  
 Steering wheel [8](#)  
 – buttons on steering wheel [9](#)  
 Switches, refer to Cockpit [8](#)  
 Symbols [4](#)

## T

Table of contents [3](#)  
 Tachometer [17](#)  
 Tailgate  
 – indicator lamp [11](#)  
 Tank capacity, refer to Fuel  
 tank capacity [41](#)  
 Tank indicator, refer to Fuel  
 gauge [17](#)  
 Technical data [38](#)  
 Temperature  
 – engine [17](#)  
 Tire, flat [18, 19](#)  
 – Flat Tire Monitor [18](#)  
 – indicator/warning lamp [11](#)  
 – M Mobility System [31](#)  
 – Tire Pressure Monitor [18](#)  
 Tire inflation pressure [27](#)  
 – loss [18](#)  
 Tire pressure monitoring,  
 refer to  
 – Flat Tire Monitor [18](#)  
 – Tire Pressure Monitor [18](#)

Tire Pressure Monitor  
 TPM [18](#)  
 – indicator/warning lamp [19](#)  
 Tires  
 – flat [18, 19](#)  
 – M Mobility System [31](#)  
 – pressure monitoring, refer to  
 Flat Tire Monitor [18](#)  
 Tool kit, refer to Onboard tool  
 kit [31](#)  
 Torque, refer to Engine  
 data [38](#)  
 TPM Tire Pressure  
 Monitor [18](#)  
 Track width, refer to  
 Dimensions [39, 40](#)  
 Traction control, refer to  
 Dynamic Stability Control  
 DSC [18](#)  
 Turning circle, refer to  
 Dimensions [39, 40](#)  
 Turn signal indicators  
 – indicator lamp [10](#)

## V

Vehicle  
 – break-in period [22](#)  
 – dimensions, refer to  
 Dimensions [39, 40](#)  
 – weight [41](#)  
 Volume  
 – fuel tank, refer to  
 Capacities [41](#)

## W

Warning and indicator  
 lamps [10](#)  
 Washer fluid reservoir, refer to  
 – Capacities [41](#)  
 Weights [41](#)  
 Wheelbase, refer to  
 Dimensions [39, 40](#)  
 Wheels and tires [27](#)  
 Width, refer to  
 Dimensions [39, 40](#)

Windshield washer reservoir  
– volume, refer to  
Capacities [41](#)  
Wrench/screwdriver, refer to  
Onboard tool kit [31](#)



## Refueling

So that you have important specifications available to you when you stop to refuel, we recommend that you fill out this table with the data that apply to your vehicle. The index of this Supplementary Owner's Manual, or the index of the BMW Z4 Owner's Manual, directs you to the respective information.

## Fuel

Specifications

Please enter your preferred fuel here.

## Engine oil

Preferred oil grade

The oil volume between the two marks on the oil dipstick corresponds to approx.  
1.4 US quarts/1.3 liters.

## Tire inflation pressures

	Summer tires Front	Rear	Winter tires Front	Rear
Up to 2 persons				
2 persons plus luggage				

More about BMW

[bmwusa.com](http://bmwusa.com)



The Ultimate  
Driving Machine

01 41 0 013 330 ue

